

MS1 Series

Servo Motor Selection Guide



Preface

Thank you for purchasing the MS1 series servo motor.

As the latest generation of servo motors developed by Inovance, MS1 series servo motors carry a power range covering 30 W to 7.5 kW, with flange sizes ranging from 25 mm to 180 mm. Multiple types of inertia and speed configurations and encoders are available for MS1 series servo motors.

MS1 series servo motors serve to achieve quick and accurate position control, speed control and torque control in automation equipment such as semiconductors, SMT machines, PCB punching machines, material handling machineries, machine tools, and transmission machineries.

MS1 series servo motors of 30 W are newly developed and those of 50 W to 1 kW are upgraded with substantial improvements in respects of the length, protection, overload capacity, and torque fluctuation.

This user guide presents information including product descriptions, installation instructions, and cable connections. If you have any question concerning the product function or performance, contact Inovance for technical support.

Documents provided by Inovance are subject to change without notice due to continuous product improvement.

| Notes | |
|-------|--|
| ◆ | The drawings in the user guide are sometimes shown without covers or protective guards. Install the covers or protective guards as specified first, and then perform operations in accordance with the instructions described in the user guide. |
| ◆ | The drawings in the user guide are shown for descriptions only and may not match the product you purchased. |
| ◆ | The user guide is subject to change without notice due to product upgrade, specification modifications as well as efforts to improve the accuracy and convenience of the user guide. |

Revision History

| Date | Version | Revision |
|---------------|---------|---|
| May 2018 | A00 | First release |
| January 2019 | A01 | Added with a note for the flexible cable |
| December 2019 | B00 | <ul style="list-style-type: none"> ◆ Added with information related to MS1H2/MS1H3 motors. ◆ Updated information related to the matching servo drive and cable connections. ◆ Added with descriptions for the oil seal and flat key disassembly. ◆ Updated outline drawings of the motor. |

| Date | Version | Revision |
|---------------|---------|--|
| October 2020 | C00 | <ul style="list-style-type: none">◆ Updated structure of the user guide.◆ Added with motor technical data and dimension drawings.◆ Added with examples for selecting motor capacities, information of connectors and applicable cables, and descriptions for overload capacities of the servo drive applicable to the motor.◆ Deleted descriptions for air-cooled motors. |
| November 2020 | C01 | <ul style="list-style-type: none">◆ Made minor corrections.◆ Updated the motor namplate. |
| February 2021 | C02 | <ul style="list-style-type: none">◆ Updated the description for IP rating of the enclosure. |

Contents

| | |
|--|----|
| Preface | 1 |
| Revision History | 1 |
| Safety Instructions | 6 |
| Safety Precautions..... | 6 |
| Safety Levels and Definitions | 6 |
| Safety Instructions..... | 6 |
| Safety Signs..... | 11 |
| 1 Product Information | 12 |
| 1.1 Motor Nameplate and Model Number | 12 |
| 1.2 Components | 13 |
| 1.3 System Wiring Diagram | 15 |
| 1.4 General Specifications | 16 |
| 1.4.1 Mechanical Characteristics..... | 16 |
| 1.4.2 Overload Characteristics | 16 |
| 1.4.3 Overload Capacities in Case of SV660 Series Servo Drives | 18 |
| 1.4.4 Derating Curves..... | 19 |
| 1.4.5 Service Life Curve of the Oil Seal | 20 |
| 1.5 Motor Model List | 20 |
| 2. Motor Model Selection..... | 22 |
| 2.1 Descriptions for Motor Model Selection..... | 22 |
| 2.2 Motors with Low Inertia and Small Capacity (MS1H1)..... | 23 |
| 2.2.1 MS1H1-03B30CB-U210Z-S..... | 23 |
| 2.2.2 MS1H1-05B30CB-*33*Z(-S) | 24 |
| 2.2.3 MS1H1-10B30CB-*33*Z(-S)..... | 26 |
| 2.2.4 MS1H1-20B30CB-*33*Z(-S)..... | 28 |
| 2.2.5 MS1H1-40B30CB-*33*Z(-S) | 30 |
| 2.2.6 MS1H1-55B30CB-*33*Z(-S)..... | 32 |
| 2.2.7 MS1H1-75B30CB-*33*Z(-S)..... | 34 |
| 2.2.8 MS1H1-10C30CB-*33*Z(-S)..... | 36 |
| 2.3 Motors with Low Inertia and Medium Capacity (MS1H2) | 38 |
| 2.3.1 MS1H2-10C30CB-A33*Z | 38 |
| 2.3.2 MS1H2-15C30CB-A33*Z | 39 |
| 2.3.3 MS1H2-10C30CD-A33*Z | 40 |

| | |
|--|----|
| 2.3.4 MS1H2-15C30CD-A33*Z | 41 |
| 2.3.5 MS1H2-20C30CD-A331Z | 42 |
| 2.3.6 MS1H2-20C30CD-A334Z-S4 | 43 |
| 2.3.7 MS1H2-25C30CD-A331Z | 44 |
| 2.3.8 MS1H2-25C30CD-A334Z-S4 | 45 |
| 2.3.9 MS1H2-30C30CD-A331Z | 46 |
| 2.3.10 MS1H2-30C30CD-A334Z-S4 | 47 |
| 2.3.11 MS1H2-40C30CD-A331Z | 48 |
| 2.3.12 MS1H2-40C30CD-A334Z-S4 | 49 |
| 2.3.13 MS1H2-50C30CD-A331Z | 50 |
| 2.3.14 MS1H2-50C30CD-A334Z-S4 | 51 |
| 2.4 Motors with Medium Inertia and Small Capacity (MS1H4) | 52 |
| 2.4.1 MS1H4-40B30CB-*33*Z(-S) | 52 |
| 2.4.2 MS1H4-75B30CB-*33*Z(-S) | 54 |
| 2.5 Motors with Medium Inertia and Medium Capacity (MS1H3) | 56 |
| 2.5.1 MS1H3-85B15CB-*33*Z | 56 |
| 2.5.2 MS1H3-13C15CB-*33*Z | 57 |
| 2.5.3 MS1H3-85B15CD-*33*Z | 58 |
| 2.5.4 MS1H3-13C15CD-*33*Z | 59 |
| 2.5.5 MS1H3-18C15CD-*33*Z | 60 |
| 2.5.6 MS1H3-29C15CD-A33*Z | 61 |
| 2.5.7 MS1H3-44C15CD-A33*Z | 62 |
| 2.5.8 MS1H3-55C15CD-A33*Z | 63 |
| 2.5.9 MS1H3-75C15CD-A33*Z | 64 |
| 3. Cables | 65 |
| 3.1 Cable Models | 65 |
| 3.1.1 Encoder Cable Model | 65 |
| 3.1.2 Power Cable Model | 65 |
| 3.2 Cables Types | 66 |
| 3.3 Selection of Motor Cables and Connectors | 67 |
| 3.3.1 IS620 Series Servo Drives | 67 |
| 3.3.2 IS810N-INT Series Servo Drives | 71 |
| 3.3.3 IS810P Series Servo Drives | 75 |
| 3.3.4 SV820N Series Servo Drives | 79 |
| 3.3.5 SV660P/N Series Servo Drives | 81 |
| 3.4 Cable Connections | 85 |

| | |
|--|-----|
| 3.4.1 Connecting Motor Power Cables..... | 85 |
| 3.4.2 Connecting the Absolute Encoder | 95 |
| 3.4.3 Requirements for connecting connectors..... | 105 |
| Appendix A Motor Selection Examples..... | 107 |
| A.1 Examples for Position Control | 107 |
| A.2 Examples for Speed Control | 111 |
| Appendix B: Disassembly of the Flat Key and Oil Seal | 115 |

Safety Instructions

Safety Precautions

- 1) Before installing, using, and maintaining this equipment, read the safety information and precautions thoroughly, and comply with them during operations.
- 2) To ensure the safety of humans and equipment, follow the signs on the equipment and all the safety instructions in this user guide.
- 3) "CAUTION", "WARNING", and "DANGER" items in the manual do not indicate all safety precautions that need to be followed; instead, they just supplement the safety precautions.
- 4) Use this equipment according to the designated environment requirements. Damage caused by improper usage is not covered by warranty.
- 5) Inovance shall take no responsibility for any personal injuries or property damage caused by improper usage.

Safety Levels and Definitions



DANGER

indicates that failure to comply with the notice will result in severe personal injuries or even death.



WARNING

indicates that failure to comply with the notice may result in severe personal injuries or even death.



CAUTION

indicates that failure to comply with the notice may result in minor personal injuries or damage to the equipment.

Safety Instructions

| Unpacking | |
|---|--|
|  <p>CAUTION</p> | <ul style="list-style-type: none">◆ Check whether the packing is intact and whether there is damage, water seepage, damp, and deformation.◆ Unpack the package by following the package sequence. Do not hit the package with force.◆ Check whether there are damage, rust, or injuries on the surface of the equipment or equipment accessories.◆ Check whether the number of packing materials is consistent with the packing list. |

WARNING

- ◆ Do not install the equipment if you find damage, rust, or indications of use on the equipment or accessories.
- ◆ Do not install the equipment if you find water seepage, component missing or damage upon unpacking.
- ◆ Do not install the equipment if you find the packing list does not conform to the equipment you received.

Storage and Transportation

CAUTION

- ◆ Store and transport this equipment based on the storage and transportation requirements for humidity and temperature.
- ◆ Avoid transporting the equipment in environments such as water splashing, rain, direct sunlight, strong electric field, strong magnetic field, and strong vibration.
- ◆ Avoid storing this equipment for more than three months. Long-term storage requires stricter protection and necessary inspections.
- ◆ Pack the equipment strictly before transportation. Use a sealed box for long-distance transportation.
- ◆ Never transport this equipment with other equipment or materials that may harm or have negative impacts on this equipment.

WARNING

- ◆ Use professional loading and unloading equipment to carry large-scale or heavy equipment.
- ◆ When carrying this equipment with bare hands, hold the equipment casing firmly with care to prevent parts falling. Failure to comply may result in personal injuries.
- ◆ Handle the equipment with care during transportation and mind your step to prevent personal injuries or equipment damage.
- ◆ Never stand or stay below the equipment when the equipment is lifted by hoisting equipment.

Installation

WARNING

- ◆ Thoroughly read the safety instructions and user guide before installation.
- ◆ Do not modify this equipment.
- ◆ Do not rotate the equipment components or loosen fixed bolts (especially those marked in red) on equipment components.
- ◆ Do not install this equipment in places with strong electric or magnetic fields.
- ◆ When this equipment is installed in a cabinet or final equipment, protection measures such as a fireproof enclosure, electrical enclosure, or mechanical enclosure must be provided. The IP rating must meet IEC standards and local laws and regulations.



DANGER

- ◆ Equipment installation, wiring, maintenance, inspection, or parts replacement must be performed only by professionals.
- ◆ Installation, wiring, maintenance, inspection, or parts replacement must be performed only by experienced personnel who have been trained with necessary electrical information.
- ◆ Installation personnel must be familiar with equipment installation requirements and relevant technical materials.
- ◆ Before installing equipment with strong electromagnetic interference, such as a transformer, install an electromagnetic shielding device for this equipment to prevent malfunctions.

Wiring



DANGER

- ◆ Equipment installation, wiring, maintenance, inspection, or parts replacement must be performed only by professionals.
- ◆ Never perform wiring at power-on. Failure to comply will result in an electric shock.
- ◆ Before wiring, cut off all equipment power supplies. Wait at least 10 minutes before further operations because residual voltage exists after power-off.
- ◆ Make sure that the equipment is well grounded. Failure to comply will result in an electric shock.
- ◆ During wiring, follow the proper electrostatic discharge (ESD) procedures, and wear an antistatic wrist strap. Failure to comply will result in damage to internal equipment circuits.



WARNING

- ◆ Never connect the power cable to output terminals of the equipment. Failure to comply may cause equipment damage or even a fire.
- ◆ When connecting a drive with the motor, make sure that the phase sequences of the drive and motor terminals are consistent to prevent reverse motor rotation.
- ◆ Wiring cables must meet cross sectional area and shielding requirements. The shielding layer of the shielded cable must be reliably grounded at one end.
- ◆ After wiring, make sure that no screws are fallen and cables are exposed in the equipment.

Power-on

**DANGER**

- ◆ Before power-on, make sure that the equipment is installed properly with reliable wiring and the motor can be restarted.
- ◆ Before power-on, make sure that the power supply meets equipment requirements to prevent equipment damage or even a fire.
- ◆ At power-on, unexpected operations may be triggered on the equipment. Therefore, stay away from the equipment.
- ◆ After power-on, do not open the cabinet door and protective cover of the equipment. Failure to comply will result in an electric shock.
- ◆ Do not touch any wiring terminals at power-on. Failure to comply will result in an electric shock.
- ◆ Do not remove any part of the equipment at power-on. Failure to comply will result in an electric shock.

Operation

**DANGER**

- ◆ Do not touch any wiring terminals during operation. Failure to comply will result in an electric shock.
- ◆ Do not remove any part of the equipment during operation. Failure to comply will result in an electric shock.
- ◆ Do not touch the equipment enclosure, fan, or resistor for temperature detection. Failure to comply will result in heat injuries.
- ◆ Signal detection must be performed only by professionals during operation. Failure to comply will result in personal injuries or equipment damage.





**WARNING**

- ◆ Prevent metal or other objects from falling into the device during operation. Failure to comply may result in equipment damage.
- ◆ Do not start or stop the equipment using a contactor. Failure to comply may result in equipment damage.

Maintenance

**DANGER**

- ◆ Equipment installation, wiring, maintenance, inspection, or parts replacement must be performed only by professionals.
- ◆ Do not maintain the equipment at power-on. Failure to comply will result in an electric shock.
- ◆ Before maintenance, cut off all equipment power supplies and wait at least 10 minutes.

| |
|--|
|  WARNING <ul style="list-style-type: none">◆ Perform daily and periodic inspection and maintenance for the equipment according to maintenance requirements and keep a maintenance record. |
| Repair |
|  DANGER <ul style="list-style-type: none">◆ Equipment installation, wiring, maintenance, inspection, or parts replacement must be performed only by professionals.◆ Do not repair the equipment at power-on. Failure to comply will result in an electric shock.◆ Before inspection and repair, cut off all equipment power supplies and wait at least 10 minutes. |
|  WARNING <ul style="list-style-type: none">◆ Require for repair services according to the product warranty agreement.◆ When the equipment is faulty or damaged, require professionals to perform troubleshooting and repair by following repair instructions and keep a repair record.◆ Replace quick-wear parts of the equipment according to the replacement guide.◆ Do not operate damaged equipment. Failure to comply may result in worse damage.◆ After the equipment is replaced, perform wiring inspection and parameter settings again. |
| Disposal |
|  WARNING <ul style="list-style-type: none">◆ Dispose of retired equipment by following local regulations or standards. Failure to comply may result in property damage, personal injuries, or even death.◆ Recycle retired equipment by following industry waste disposal standards to avoid environmental pollution. |

Safety Signs

- Description of safety signs in the user guide



Read the user guide before installation and operation.



Reliably ground the system and equipment.



Danger!



High temperature!



Prevent personal injuries caused by machines.



High voltage!

1 Product Information

1.1 Motor Nameplate and Model Number

Model: MS1 H1 - 40B 30C B Type: A3 3 1 Z

| Code | Series No. |
|------|------------------------|
| MS1 | MS1 series servo motor |

| Code | Product Series |
|------|------------------------------------|
| H | Max. speed higher than rated speed |
| V | Max. speed equal to rated speed |

| Code | Type |
|------|---------------------------------|
| 1 | Low inertia, small capacity |
| 2 | Low inertia, medium capacity |
| 3 | Medium inertia, medium capacity |
| 4 | Medium inertia, small capacity |

| Code | Rated Power (W) |
|--------------------------------------|-----------------|
| Comprised of two digits and a letter | |
| B | x10 |
| C | x100 |
| Example: 40B: 400 W | |

| Code | Rated Speed (RPM) |
|--------------------------------------|-------------------|
| Comprised of two digits and a letter | |
| B | x10 |
| C | x100 |
| Example: 30C: 3000 RPM | |

| Code | Connection Type |
|------|----------------------|
| Z | Terminal-type motor |
| Z-S | Lead wire-type motor |

| Code | Brake, Reducer, Oil Seal |
|------|--------------------------|
| 0 | None |
| 1 | Oil seal |
| 2 | Brake |
| 4 | Oil seal+Brake |

| Code | Shaft Connection Mode |
|------|-----------------------------------|
| 1 | Plain shaft* |
| 3 | Solid, with key and threaded hole |

| Code | Encoder Type |
|-----------------------------------|-------------------------------------|
| Comprised of a digit and a letter | |
| A3 | 23-bit multi-turn absolute encoder |
| T3 | 18-bit multi-turn encoder |
| U2 | 20-bit single-turn absolute encoder |

| Code | Voltage Class |
|------|---------------|
| B | 220 V |
| D | 380 V |

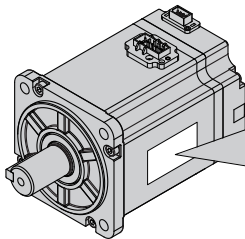

Nameplate

INOVANCE

AC Servo Motor

Model: MS1H4-75B30CB Type: A331Z

Motor model → 0.75 kW 220 V 3000 r/min

Motor specifications → 2.39 N·m 250 Hz 4.8 A

Duty S1 Ins. F 3PHAC IP67

Motor code → Motor Code: 14101 Weight: 2.4 kg

Serial No. → Suzhou Inovance Technology Co.,Ltd.
Made in China SN: 0111084000000001

Figure 1-1 Motor model and nameplate



Those marked with an asterisk are dedicated for motors in flange size 25.

1.2 Components

■ The following figures show the components of motors in flange sizes 40, 60, and 80.

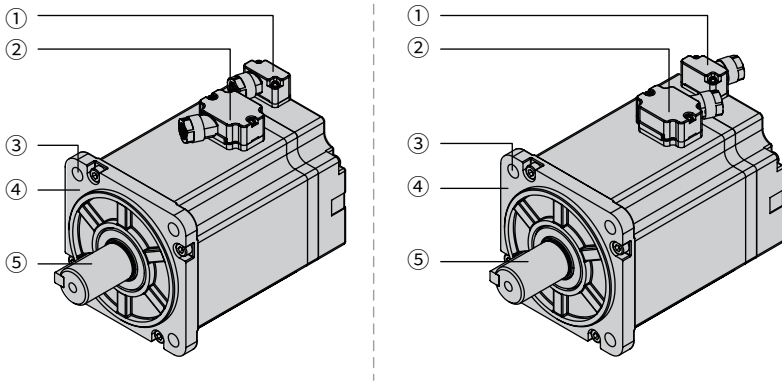

Figure 1-2 Components of terminal-type motors in flange sizes 40, 60 and 80

| No. | Name |
|-----|-----------------------------|
| ① | Encoder connector |
| ② | Power connector |
| ③ | Mounting flange face |
| ④ | Mounting screw through-hole |
| ⑤ | Shaft extension (keyed) |

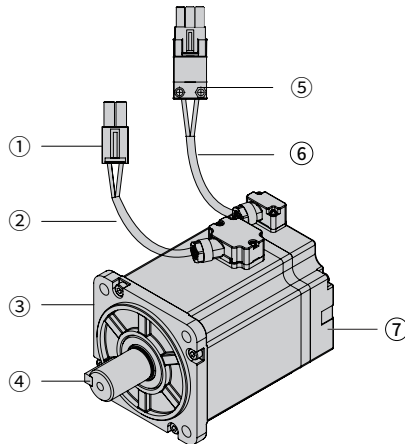

Figure 1-3 Components of lead wire-type motors in flange sizes 40, 60, and 80

| No. | Name |
|-----|--------------------------|
| ① | Power cable connector |
| ② | Power cable |
| ③ | Mounting flange face |
| ④ | Shaft output |
| ⑤ | Encoder connector |
| ⑥ | Encoder cable |
| ⑦ | Encoder (detection part) |

■ The following figure shows components of motors in flange sizes 100, 130, and 180.

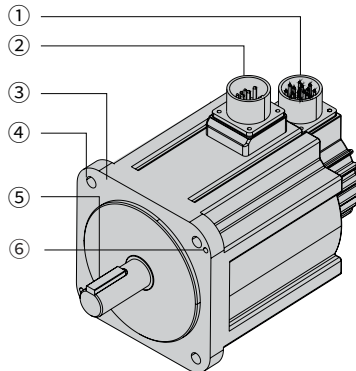

Figure 1-4 Components of connector-type motors in flange sizes 100, 130, and 180

| No. | Name |
|-----|--------------------------------|
| ① | Encoder aviation connector |
| ② | Power cable aviation connector |
| ③ | Mounting flange face |
| ④ | Mounting screw through-hole |
| ⑤ | Shaft extension (keyed) |
| ⑥ | Hole for disassembly |

1.3 System Wiring Diagram

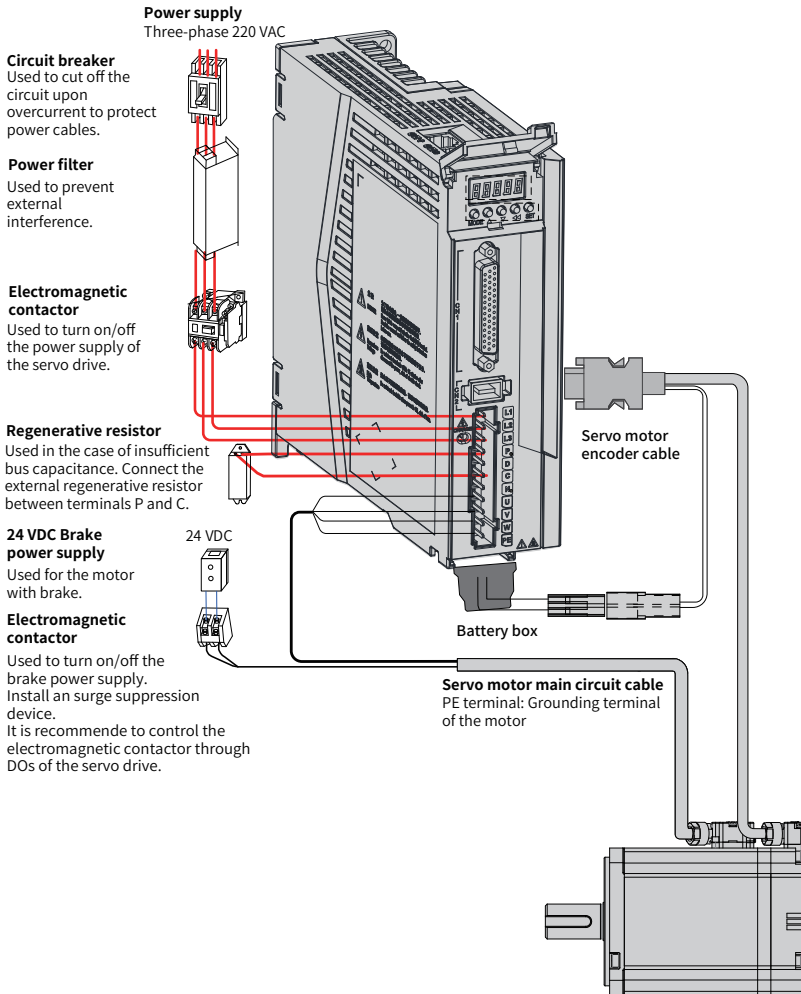

Figure 1-5 Wiring of three-phase 220 V servo systems

1.4 General Specifications

1.4.1 Mechanical Characteristics

| No. | Function |
|----------------------------|---|
| Duty type | Continuous |
| Vibration level | V15 |
| Insulation resistance | 500 VDC, above 10 MΩ |
| Ambient temperature | 0°C to 40°C |
| Storage temperature | -20° C to +60° C (Peak temperature: 80° C for 72 hours) |
| Excitation mode | Permanent magnetic |
| Mounting method | Flange |
| Heat resistance level | Level F |
| Insulation voltage | 1500 VAC, 1 minute (220 V level) 1800 VAC, 1 minute (380 V level) |
| IP rating of the enclosure | IP67 (except the shaft opening) |
| Ambient humidity | 20%–80% (no condensation) |
| Direction of rotation | Rotates counterclockwise (CCW) when viewed from the load side with the forward run command. |
| Vibration | Below 49 m/s ² |
| Shock | Below 490 m/s ² |
| Altitude | < 1000 m (derating required for altitudes above 1000 m) |

1.4.2 Overload Characteristics

- MS1H1 (motors in flange size 25 excluded)/MS1H2/MS1H3/MS1H4

| Load Ratio (%) | Operating Time (s) |
|----------------|--------------------|
| 120 | 230 |
| 130 | 80 |
| 140 | 40 |
| 150 | 30 |
| 160 | 20 |
| 170 | 17 |
| 180 | 15 |
| 190 | 12 |
| 200 | 10 |
| 210 | 8.5 |
| 220 | 7 |
| 230 | 6 |
| 240 | 5.5 |

| Load Ratio (%) | Operating Time (s) |
|----------------|--------------------|
| 250 | 5 |
| 300 | 3 |
| 350 | 2 |

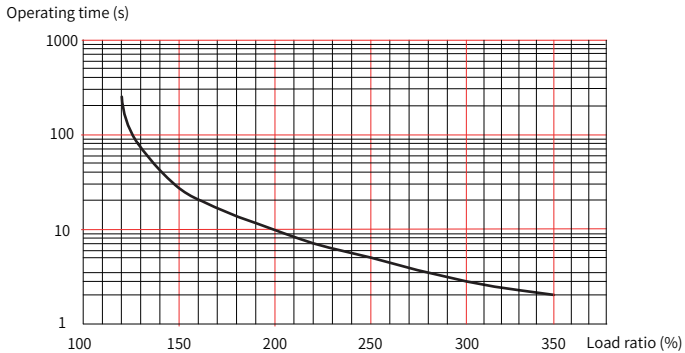

Figure 1-6 Motor overload curve



NOTE

- ◆ The maximum torque of H1 and H4 models is 3.5 times the rated torque.
- ◆ The maximum torque of H2 models is three times the rated torque.
- ◆ The maximum torque of H3 models, except for those of 2.9 kW, is 2.5 times the rated torque.
- ◆ For models of 2.9 kW, the maximum torque is two times the rated torque.

■ MS1H1-03B30CB-U210Z-S

| Load Ratio (%) | Operating Time (s) |
|----------------|--------------------|
| 120 | 75.00 |
| 130 | 43.39 |
| 140 | 27.97 |
| 150 | 19.84 |
| 160 | 15.10 |
| 170 | 15.02 |
| 180 | 9.82 |
| 190 | 8.12 |
| 200 | 6.70 |
| 210 | 5.62 |
| 220 | 4.79 |
| 230 | 4.14 |
| 240 | 3.63 |
| 250 | 3.22 |
| 260 | 2.89 |

| Load Ratio (%) | Operating Time (s) |
|----------------|--------------------|
| 270 | 2.61 |
| 280 | 2.38 |
| 290 | 2.18 |
| 300 | 2.01 |
| 310 | 1.86 |
| 320 | 1.73 |
| 330 | 1.60 |
| 340 | 1.50 |
| 350 | 1.40 |

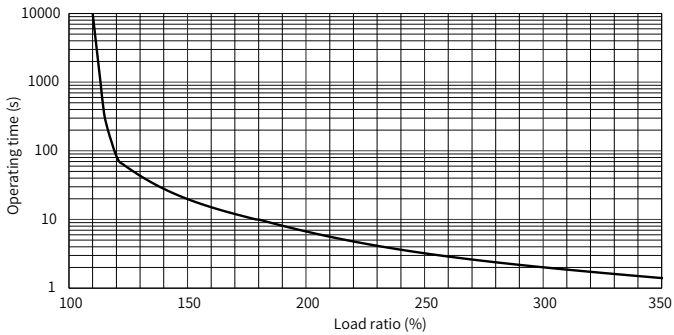

Figure 1-7 Overload curve of MS1H1-03B30CB-U210Z-S series motors

1.4.3 Overload Capacities in Case of SV660 Series Servo Drives

| Motor Model | Applicable Servo Drive | Overload Ratio |
|-------------------------|------------------------|----------------|
| MS1H1-03B30CB-U210Z-S | SV660P(N)S1R6 | 3.5 |
| MS1H1-05B30CB-*33*Z(-S) | | |
| MS1H1-10B30CB-*33*Z(-S) | | |
| MS1H1-20B30CB-*33*Z(-S) | | |
| MS1H1-40B30CB-*33*Z(-S) | SV660P(N)S2R8 | 3.5 |
| MS1H1-55B30CB-*33*Z(-S) | SV660P(N)S5R5 | 3.5 |
| MS1H1-75B30CB-*33*Z(-S) | | |
| MS1H1-10C30CB-*33*Z(-S) | SV660P(N)S7R6 | 3 |
| | SV660P(N)S012 | 3.5 |
| MS1H2-10C30CB-A33*Z | SV660P(N)S7R6 | 3 |
| MS1H2-10C30CD-A33*Z | SV660P(N)T5R4 | 3 |
| MS1H2-15C30CB-A33*Z | SV660P(N)S012 | 3 |
| MS1H2-15C30CD-A33*Z | SV660P(N)T5R4 | 3 |

| Motor Model | Applicable Servo Drive | Overload Ratio |
|--------------------------|------------------------|----------------|
| MS1H2-20C30CD-A33*Z(-S4) | SV660P(N)T8R4 | 3 |
| MS1H2-25C30CD-A33*Z(-S4) | SV660P(N)T8R4 | 2.5 |
| | SV660P(N)T012 | 3 |
| MS1H2-30C30CD-A33*Z(-S4) | SV660P(N)T012 | 3 |
| MS1H2-40C30CD-A33*Z(-S4) | SV660P(N)T017 | 3 |
| MS1H2-50C30CD-A33*Z(-S4) | SV660P(N)T017 | 2.5 |
| | SV660P(N)T021 | 3 |
| MS1H3-85B15CB-*33*Z | SV660P(N)S7R6 | 2.5 |
| MS1H3-13C15CB-*33*Z | SV660P(N)S012 | 2.5 |
| MS1H3-85B15CD-*33*Z | SV660P(N)T3R5 | 2.5 |
| MS1H3-13C15CD-*33*Z | SV660P(N)T5R4 | 2.5 |
| MS1H3-18C15CD-*33*Z | SV660P(N)T8R4 | 2.5 |
| MS1H3-29C15CD-A33*Z | SV660P(N)T012 | 2.5 |
| MS1H3-44C15CD-A33*Z | SV660P(N)T017 | 2.5 |
| MS1H3-55C15CD-A33*Z | SV660P(N)T021 | 2.5 |
| MS1H3-75C15CD-A33*Z | SV660P(N)T026 | 2.5 |
| MS1H4-40B30CB-*33*Z(-S) | SV660P(N)S2R8 | 3.5 |
| MS1H4-75B30CB-*33*Z(-S) | SV660P(N)S5R5 | 3.5 |

1.4.4 Derating Curves

■ Altitude-based derating curve

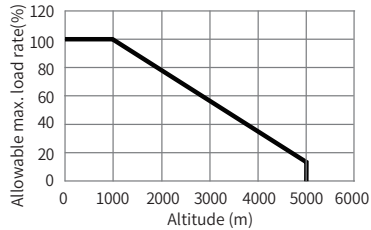

■ Temperature-based derating curve

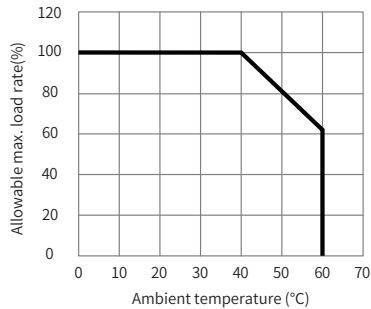

1.4.5 Service Life Curve of the Oil Seal

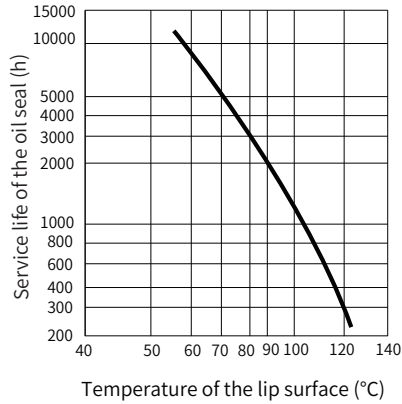

1.5 Motor Model List

| Inertia Capacity | Flange Size (mm) | Output (kW) | Voltage Class (V) | Motor Model | Page |
|---|--|-------------|---------------------|-------------------------|--------------------|
| MS1H1 low inertia, small capacity | 25 | 0.03 | 220 | MS1H1-03B30CB-U210Z-S | 23 |
| | 40 | 0.05 | | MS1H1-05B30CB-*33*Z(-S) | 24 |
| | 40 | 0.1 | | MS1H1-10B30CB-*33*Z(-S) | 26 |
| | 60 | 0.2 | | MS1H1-20B30CB-*33*Z(-S) | 28 |
| | 60 | 0.4 | | MS1H1-40B30CB-*33*Z(-S) | 30 |
| | 80 | 0.55 | | MS1H1-55B30CB-*33*Z(-S) | 32 |
| | 80 | 0.75 | | MS1H1-75B30CB-*33*Z(-S) | 34 |
| | 80 | 1 | | MS1H1-10C30CB-*33*Z(-S) | 36 |
| | MS1H2 low inertia, medium capacity | 100 | | 1 | 220 |
| 100 | | 1.5 | MS1H2-15C30CB-A33*Z | 39 | |
| 100 | | 1 | 380 | MS1H2-10C30CD-A33*Z | 40 |
| 100 | | 1.5 | | MS1H2-15C30CD-A33*Z | 41 |
| 100 | | 2 | | MS1H2-20C30CD-A331Z | 42 |
| 100 | | 2 | | MS1H2-20C30CD-A334Z-S4 | 43 |
| 100 | | 2.5 | | MS1H2-25C30CD-A331Z | 44 |
| 100 | | 2.5 | | MS1H2-25C30CD-A334Z-S4 | 45 |
| 130 | | 3 | | MS1H2-30C30CD-A331Z | 46 |
| 130 | | 3 | | MS1H2-30C30CD-A334Z-S4 | 47 |
| 130 | | 4 | | MS1H2-40C30CD-A331Z | 48 |
| 130 | | 4 | | MS1H2-40C30CD-A334Z-S4 | 49 |
| 130 | | 5 | | MS1H2-50C30CD-A331Z | 50 |
| 130 | | 5 | | MS1H2-50C30CD-A334Z-S4 | 51 |

| Inertia Capacity | Flange Size (mm) | Output (kW) | Voltage Class (V) | Motor Model | Page |
|---|------------------|-------------|-------------------|-------------------------|--------------------|
| MS1H4 medium inertia, low capacity | 60 | 0.4 | 220 | MS1H4-40B30CB-*33*Z(-S) | 52 |
| | 80 | 0.75 | | MS1H4-75B30CB-*33*Z(-S) | 54 |
| MS1H3 medium inertia, medium capacity | 130 | 0.85 | 220 | MS1H3-85B15CB-*33*Z | 56 |
| | 130 | 1.3 | | MS1H3-13C15CB-*33*Z | 57 |
| | 130 | 0.85 | 380 | MS1H3-85B15CD-*33*Z | 58 |
| | 130 | 1.3 | | MS1H3-13C15CD-*33*Z | 59 |
| | 130 | 1.8 | | MS1H3-18C15CD-*33*Z | 60 |
| | 180 | 2.9 | | MS1H3-29C15CD-A33*Z | 61 |
| | 180 | 4.4 | | MS1H3-44C15CD-A33*Z | 62 |
| | 180 | 5.5 | | MS1H3-55C15CD-A33*Z | 63 |
| | 180 | 7.5 | | MS1H3-75C15CD-A33*Z | 64 |

2. Motor Model Selection

2.1 Descriptions for Motor Model Selection

- Motors with oil seal must be derated by 10% during use.
- The brake cannot share the same power supply with other electrical devices. This is to prevent malfunction of the brake due to voltage or current drop caused by other working devices.
- It is recommended to use cables of 0.5 mm^2 and above.
- Technical data and torque-speed characteristic values in the following tables are obtained when motors equipped with the following heatsinks are working with Inovance servo drives under an armature coil temperature of 20°C .

MS1H1/MS1H4: 250 mm x 250 mm x 6 mm (aluminum)

MS1H2-10C to 25C: 300 mm x 300 mm x 12 mm (aluminum)

MS1H2-30C to 50C: 400 mm x 400 mm x 20 mm (aluminum)

MS1H3-85B to 18C: 400 mm x 400 mm x 20 mm (iron)

MS1H3-29C to 75C: 360 mm x 360 mm x 25 mm (dual-layer aluminum plate)

- Radial and axial loads of the motor

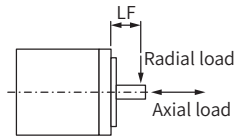

Figure 2-1 Radial and axial loads of the motor

- The tightening tension for terminal screws is $0.19 \text{ N} \cdot \text{m}$ to $0.21 \text{ N} \cdot \text{m}$, exceeding of which may damage the terminal.
- In the following dimension drawings and subsequent tables, dimensions are represented in millimeters (mm) and values inside brackets are for the motor with holding brake.
- Motor models ending with "-S4" represent the duty type S4, indicating the motor is working under S4 duty, with the motor load ratio not exceeding 70%.

2.2 Motors with Low Inertia and Small Capacity (MS1H1)

2.2.1 MS1H1-03B30CB-U210Z-S

| Technical Data for Motors in Flange Size 25 (mm) (Low Inertia, Small Capacity) | |
|---|---------|
| Rated output (kW) | 0.03 |
| Voltage (V) | 220 |
| Rated torque (N·m) | 0.0955 |
| Maximum torque (N·m) | 0.33 |
| Rated current (Arms) | 0.93 |
| Maximum current (Arms) | 4.2 |
| Rated speed (RPM) | 3000 |
| Maximum speed (RPM) | 6000 |
| Torque coefficient (N·m/Arms) | 0.11 |
| Rotor moment of inertia (kg·cm ²) | 0.00668 |

■ Torque-Speed characteristics

- A — Continuous working area
- B — Short-term working area

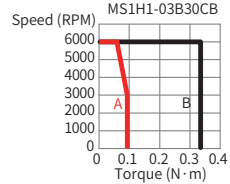

■ Heatsink-based derating curve

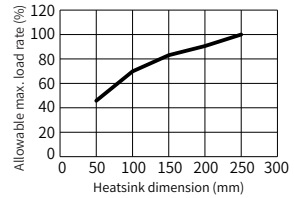

■ Allowable load

| LF (mm) | Allowable Radial Load (N) | Allowable Axial Load (N) |
|---------|---------------------------|--------------------------|
| 20 | 78 | 54 |

■ Dimension drawing

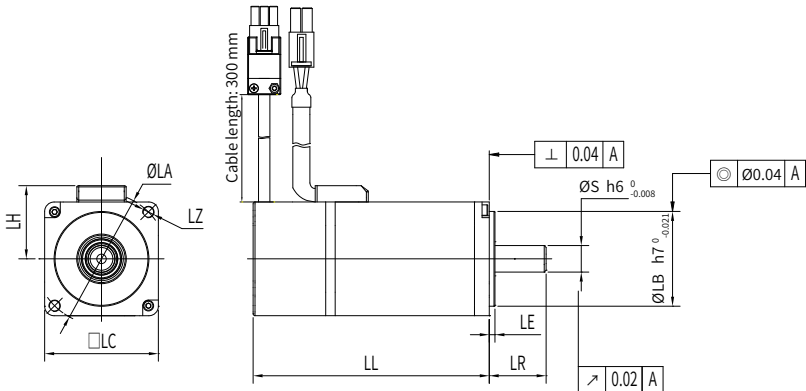

| | | | | | | | | |
|------|----|--------|----|----|----|----|---------|-------------|
| LL | LC | LR | LA | LZ | LH | LG | LE | LJ |
| 73.5 | 25 | 16±0.5 | 28 | 3 | 17 | - | 2.5±0.3 | - |
| S | LB | TP | LK | KH | KW | W | T | Weight (kg) |
| 5 | 20 | - | - | - | - | - | - | 0.2 |

2.2.2 MS1H1-05B30CB-*33*Z(-S)

| Technical Data for Motors in Flange size 40 (mm) (Low Inertia, Small Capacity) | | |
|---|---------------------|-------|
| Rated output (kW) | 0.05 | |
| Voltage (V) | 220 | |
| Rated torque (N·m) | 0.16 | |
| Maximum torque (N·m) | 0.56 | |
| Rated current (Arms) | 1.3 | |
| Maximum current (Arms) | 4.70 | |
| Rated speed (RPM) | 3000 | |
| Maximum speed (RPM) | 6000 | |
| Torque coefficient (N·m/Arms) | 0.15 | |
| Rotor moment of inertia (kg·cm ²) | Motor without brake | 0.026 |
| | Motor with brake | 0.028 |

■ Torque-Speed characteristics

- A — Continuous working area
- B — Short-term working area

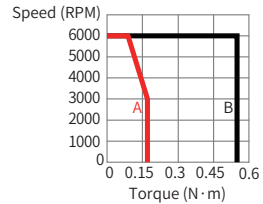

■ Heatsink-based derating curve

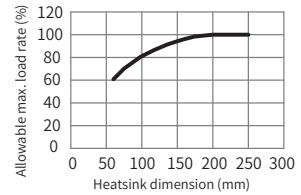

■ Electrical specifications of the motor with brake

| Holding Torque (N·m) | Supply Voltage (VDC) ±10% | Rated Power (W) | Coil Resistance (Ω) (±7%) | Exciting Current (A) | Apply Time (ms) | Release Time (ms) | Backlash (°) |
|----------------------|---------------------------|-----------------|---------------------------|----------------------|-----------------|-------------------|--------------|
| 0.32 | 24 | 6.1 | 94.4 | 0.25 | ≤ 40 | ≤ 20 | ≤ 1.5 |

■ Allowable load

| LF (mm) | Allowable Radial Load (N) | Allowable Axial Load (N) |
|---------|---------------------------|--------------------------|
| 20 | 78 | 54 |

■ Terminal-type motor

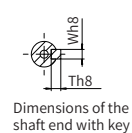
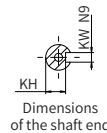
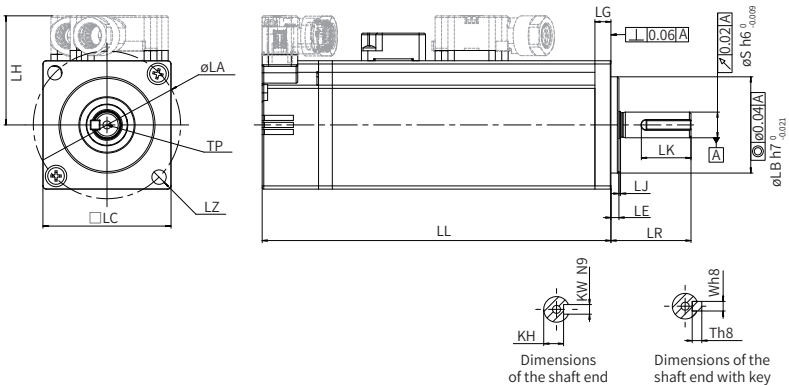

■ Lead wire-type motor

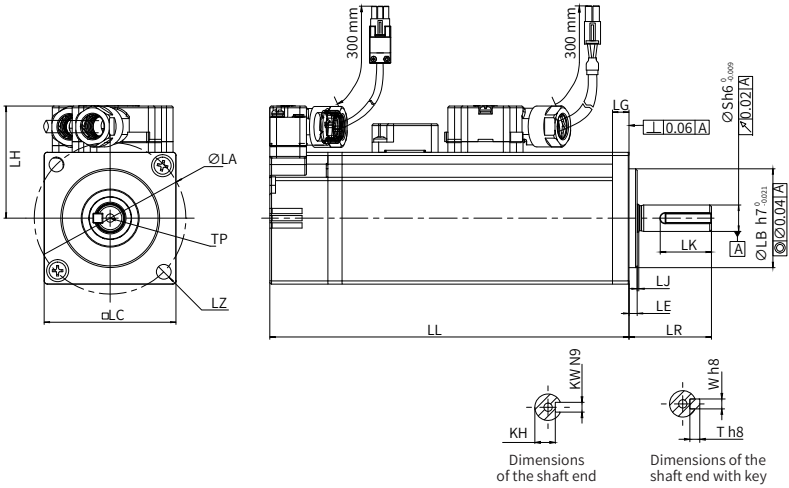

| LL | LC | LR | LA | LZ | LH | LG | LE | LJ |
|---------|----|--------|------|---------------------|----|----|---------|-------------|
| 65 (96) | 40 | 25±0.5 | 46 | 2- ϕ 4.5 | 34 | 5 | 2.5±0.5 | 0.5±0.35 |
| S | LB | TP | LK | KH | KW | W | T | Weight (kg) |
| 8 | 30 | M3x6 | 15.5 | 6.2 $\frac{0}{0.1}$ | 3 | 3 | 3 | 0.39 (0.50) |

2.2.3 MS1H1-10B30CB-*33*Z(-S)

| Technical Data for Motors in Flange Size 40 (mm) (Low Inertia, Small Capacity) | | |
|---|---------------------|-------|
| Rated output (kW) | 0.1 | |
| Voltage (V) | 220 | |
| Rated torque (N·m) | 0.32 | |
| Maximum torque (N·m) | 1.12 | |
| Rated current (Arms) | 1.3 | |
| Maximum current (Arms) | 4.70 | |
| Rated speed (RPM) | 3000 | |
| Maximum speed (RPM) | 6000 | |
| Torque coefficient (N·m/Arms) | 0.26 | |
| Rotor moment of inertia (kg·cm ²) | Motor without brake | 0.041 |
| | Motor with brake | 0.043 |

■ Torque-Speed characteristics

- A — Continuous working area
- B — Short-term working area

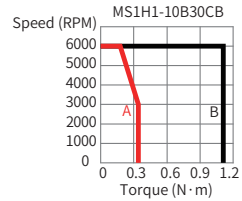

■ Heatsink-based derating curve

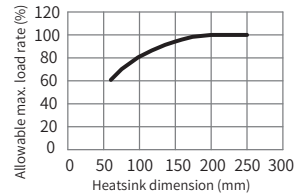

■ Electrical specifications of the motor with brake

| Holding Torque (N·m) | Supply Voltage (VDC) ±10% | Rated Power (W) | Coil Resistance (Ω) (±7%) | Exciting Current (A) | Apply Time (ms) | Release Time (ms) | Backlash (°) |
|----------------------|---------------------------|-----------------|---------------------------|----------------------|-----------------|-------------------|--------------|
| 0.32 | 24 | 6.1 | 94.4 | 0.25 | ≤ 40 | ≤ 20 | ≤ 1.5 |

■ Allowable load

| LF (mm) | Allowable Radial Load (N) | Allowable Axial Load (N) |
|---------|---------------------------|--------------------------|
| 20 | 78 | 54 |

■ Terminal-type motor

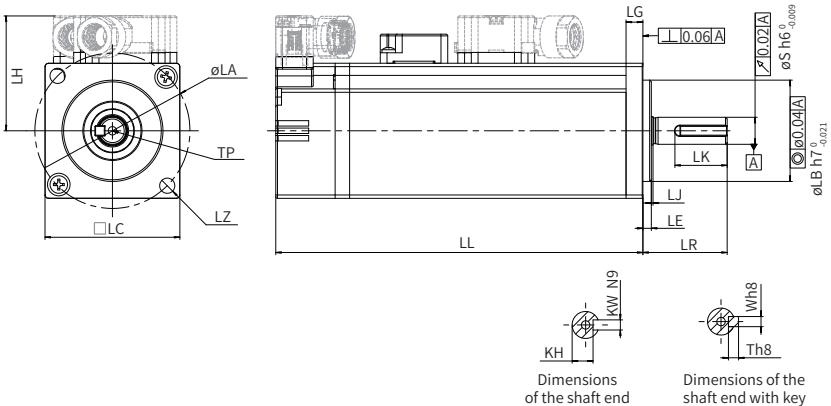

Dimensions of the shaft end

Dimensions of the shaft end with key

■ Lead wire-type motor

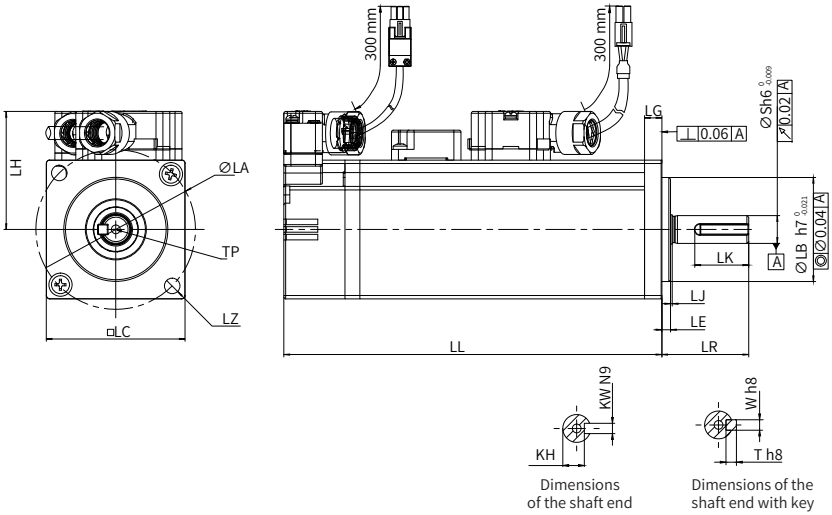

| | | | | | | | | |
|-----------|----|--------|------|----------------------------------|----|----|---------|-------------|
| LL | LC | LR | LA | LZ | LH | LG | LE | LJ |
| 77.5(109) | 40 | 25±0.5 | 46 | 2-φ4.5 | 34 | 5 | 2.5±0.5 | 0.5±0.35 |
| S | LB | TP | LK | KH | KW | W | T | Weight (kg) |
| 8 | 30 | M3x6 | 15.5 | 6.2 ⁰ _{-0.1} | 3 | 3 | 3 | 0.45 (0.64) |

2.2.4 MS1H1-20B30CB-*33*Z(-S)

| Technical Data for Motors in Flange Size 60 (mm) (Low Inertia, Small Capacity) | | |
|---|------------------------|-------|
| Rated output (kW) | 0.2 | |
| Voltage (V) | 220 | |
| Rated torque (N·m) | 0.64 | |
| Maximum torque (N·m) | 2.24 | |
| Rated current (Arms) | 1.5 | |
| Maximum current (Arms) | 5.80 | |
| Rated speed (RPM) | 3000 | |
| Maximum speed (RPM) | 6000 | |
| Torque coefficient (N·m/Arms) | 0.46 | |
| Rotor moment of inertia (kg·cm ²) | Motor without brake | 0.207 |
| | Motor with brake | 0.22 |

■ Torque-Speed characteristics

- A — Continuous working area
- B — Short-term working area

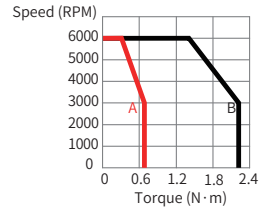

■ Heatsink-based derating curve

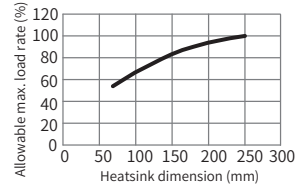

■ Electrical specifications of the motor with brake

| Holding Torque (N·m) | Supply Voltage (VDC) ±10% | Rated Power (W) | Coil Resistance (Ω) (±7%) | Exciting Current (A) | Apply Time (ms) | Release Time (ms) | Backlash (°) |
|----------------------|---------------------------|-----------------|---------------------------|----------------------|-----------------|-------------------|--------------|
| 1.5 | 24 | 7.6 | 75.79 | 0.32 | ≤ 60 | ≤ 20 | ≤ 1.5 |

■ Allowable load

| LF (mm) | Allowable Radial Load (N) | Allowable Axial Load (N) |
|---------|---------------------------|--------------------------|
| 25 | 245 | 74 |

■ Terminal-type motor

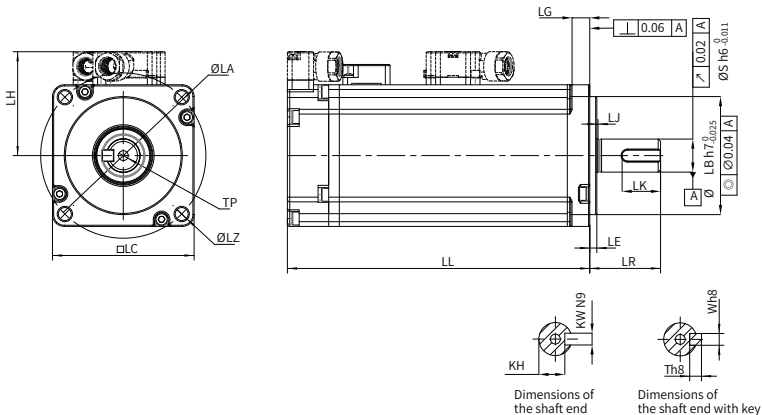

Dimensions of the shaft end

Dimensions of the shaft end with key

■ Lead wire-type motor

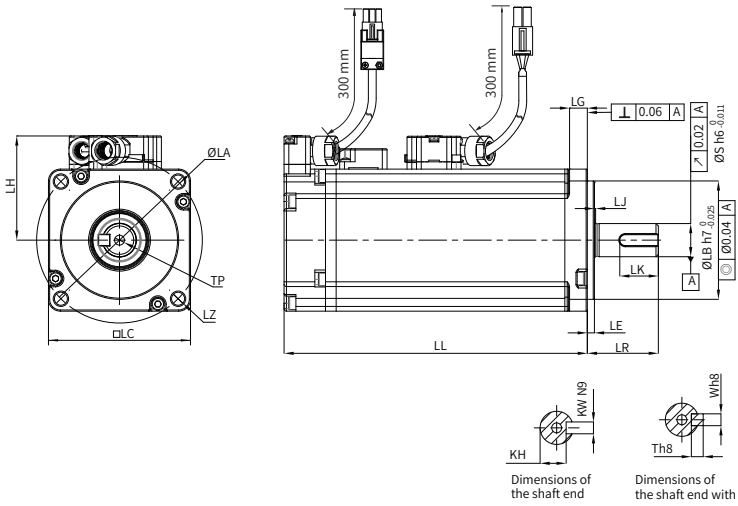

| LL | LC | LR | LA | LZ | LH | LG | LE | LJ |
|------------|----|--------|------|---------------------------------|----|-----|-------|-------------|
| 72.5 (100) | 60 | 30±0.5 | 70 | 4-φ5.5 | 44 | 7.5 | 3±0.5 | 0.5±0.35 |
| S | LB | TP | LK | KH | KW | W | T | Weight (kg) |
| 14 | 50 | M5x8 | 16.5 | 11 ⁰ _{-0.1} | 5 | 5 | 5 | 0.78 (1.16) |

2.2.5 MS1H1-40B30CB-*33*Z(-S)

| Technical Data of Motors in Flange Size 60 (mm) (Low Inertia, Small Capacity) | | |
|--|------------------------|-------|
| Rated output (kW) | 0.4 | |
| Voltage (V) | 220 | |
| Rated torque (N·m) | 1.27 | |
| Maximum torque (N·m) | 4.46 | |
| Rated current (Arms) | 2.8 | |
| Maximum current (Arms) | 10.1 | |
| Rated speed (RPM) | 3000 | |
| Maximum speed (RPM) | 6000 | |
| Torque coefficient (N·m/Arms) | 0.53 | |
| Rotor moment of inertia (kg·cm ²) | Motor without brake | 0.376 |
| | Motor with brake | 0.39 |

■ Torque-Speed characteristics

- A — Continuous working area
- B — Short-term working area

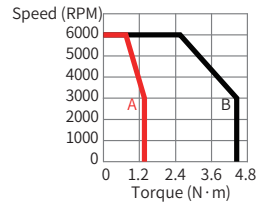

■ Heatsink-based derating curve

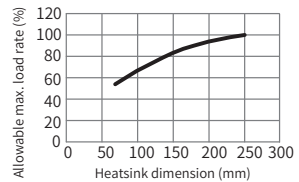

■ Electrical specifications of the motor with brake

| Holding Torque (N·m) | Supply Voltage (VDC) ±10% | Rated Power (W) | Coil Resistance (Ω) (±7%) | Exciting Current (A) | Apply Time (ms) | Release Time (ms) | Backlash (°) |
|----------------------|---------------------------|-----------------|---------------------------|----------------------|-----------------|-------------------|--------------|
| 1.5 | 24 | 7.6 | 75.79 | 0.32 | ≤ 60 | ≤ 20 | ≤ 1.5 |

■ Allowable load

| LF (mm) | Allowable Radial Load (N) | Allowable Axial Load (N) |
|---------|---------------------------|--------------------------|
| 25 | 245 | 74 |

■ Terminal-type motor

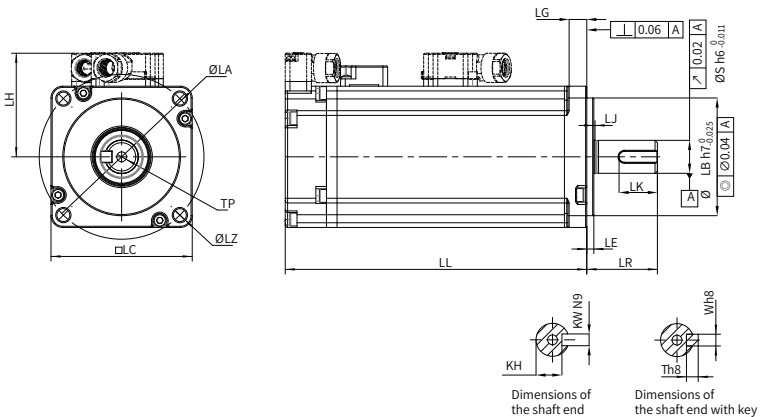

■ Lead wire-type motor

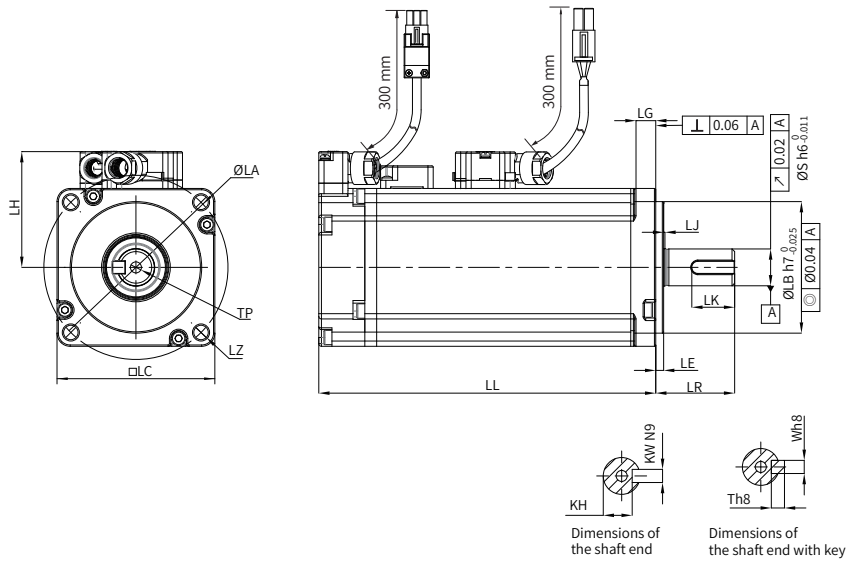

| LL | LC | LR | LA | LZ | LH | LG | LE | LJ |
|----------|----|--------|------|---------------------------------|----|-----|-------|-------------|
| 91 (119) | 60 | 30±0.5 | 70 | 4-φ5.5 | 44 | 7.5 | 3±0.5 | 0.5±0.35 |
| S | LB | TP | LK | KH | KW | W | T | Weight (kg) |
| 14 | 50 | M5x8 | 16.5 | 11 ⁰ _{-.01} | 5 | 5 | 5 | 1.11 (1.48) |

2.2.6 MS1H1-55B30CB-*33*Z(-S)

| Technical Data for Motors in Flange Size 80 (mm) (Low Inertia, Small Capacity) | |
|---|------|
| Rated output (kW) | 0.55 |
| Voltage (V) | 220 |
| Rated torque (N·m) | 1.75 |
| Maximum torque (N·m) | 6.13 |
| Rated current (Arms) | 3.8 |
| Maximum current (Arms) | 15 |
| Rated speed (RPM) | 3000 |
| Maximum speed (RPM) | 6000 |
| Torque coefficient (N·m/Arms) | 0.49 |
| Rotor moment of inertia (kg·cm ²) | 1.06 |

■ Torque-Speed characteristics

- A — Continuous working area
- B — Short-term working area

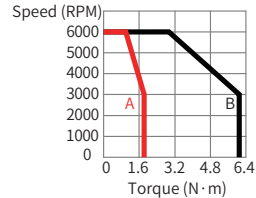

■ Heatsink-based derating curve

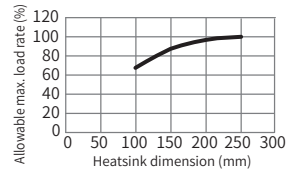

■ Allowable load

| LF (mm) | Allowable Radial Load (N) | Allowable Axial Load (N) |
|---------|---------------------------|--------------------------|
| 35 | 392 | 147 |

■ Terminal-type motor

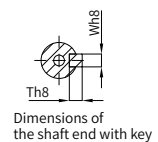
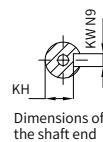
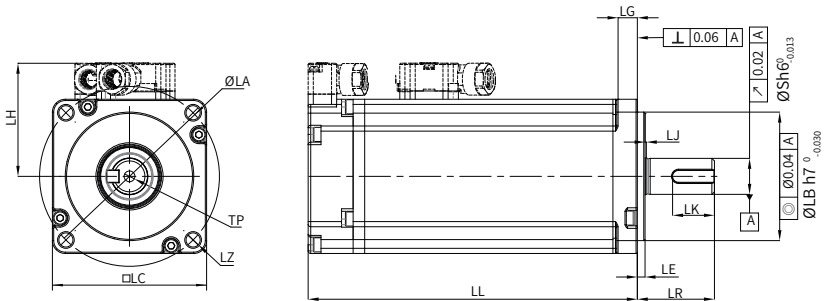

■ Lead wire-type motor

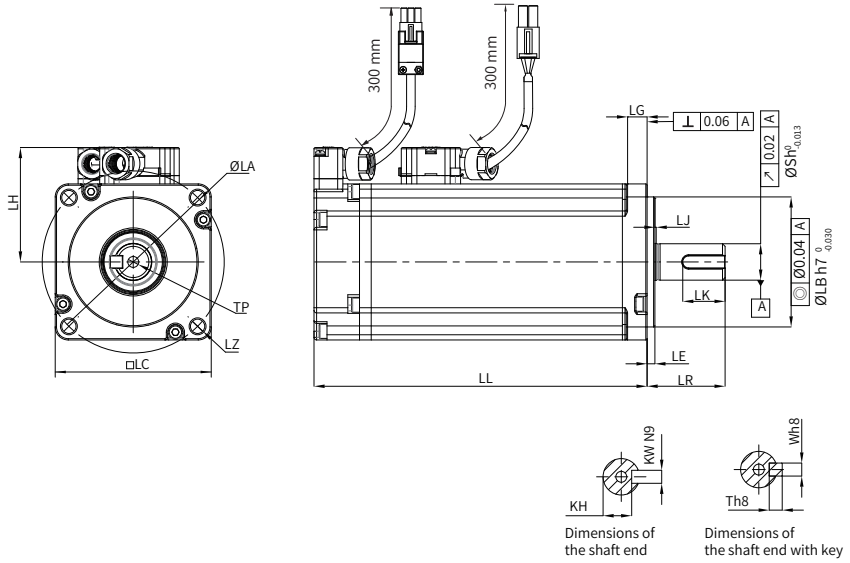

| LL | LC | LR | LA | LZ | LH | LG | LE | LJ |
|------|----|--------|----|----------------------------------|----|-----|-------|-------------|
| 96.2 | 80 | 35±0.5 | 90 | 4-φ7 | 54 | 7.7 | 3±0.5 | 0.5±0.35 |
| S | LB | TP | LK | KH | KW | W | T | Weight (kg) |
| 19 | 70 | M6x20 | 25 | 15.5 ⁰ _{0.1} | 6 | 6 | 6 | 1.85 |

2.2.7 MS1H1-75B30CB-*33*Z(-S)

| Technical Data for Motors in Flange Size 80 (mm) (Low Inertia, Small Capacity) | | |
|---|---------------------|------|
| Rated output (kW) | 0.75 | |
| Voltage (V) | 220 | |
| Rated torque (N·m) | 2.39 | |
| Maximum torque (N·m) | 8.36 | |
| Rated current (Arms) | 4.8 | |
| Maximum current (Arms) | 16.9 | |
| Rated speed (RPM) | 3000 | |
| Maximum speed (RPM) | 6000 | |
| Torque coefficient (N·m/Arms) | 0.58 | |
| Rotor moment of inertia (kg·cm ²) | Motor without brake | 1.38 |
| | Motor with brake | 1.43 |

■ Torque-Speed characteristics

- A — Continuous working area
- B — Short-term working area

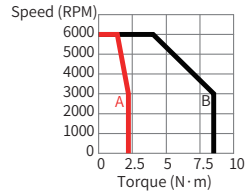

■ Heatsink-based derating curve

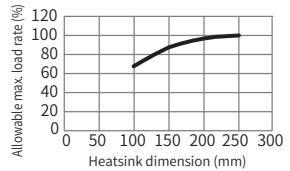

■ Electrical specifications of the motor with brake

| Holding Torque (N·m) | Supply Voltage (VDC) ±10% | Rated Power (W) | Coil Resistance (Ω) (±7%) | Exciting Current (A) | Apply Time (ms) | Release Time (ms) | Backlash (°) |
|----------------------|---------------------------|-----------------|---------------------------|----------------------|-----------------|-------------------|--------------|
| 3.2 | 24 | 10 | 57.6 | 0.42 | ≤ 60 | ≤ 40 | ≤ 1 |

■ Allowable load

| LF (mm) | Allowable Radial Load (N) | Allowable Axial Load (N) |
|---------|---------------------------|--------------------------|
| 35 | 392 | 147 |

■ Terminal-type motor

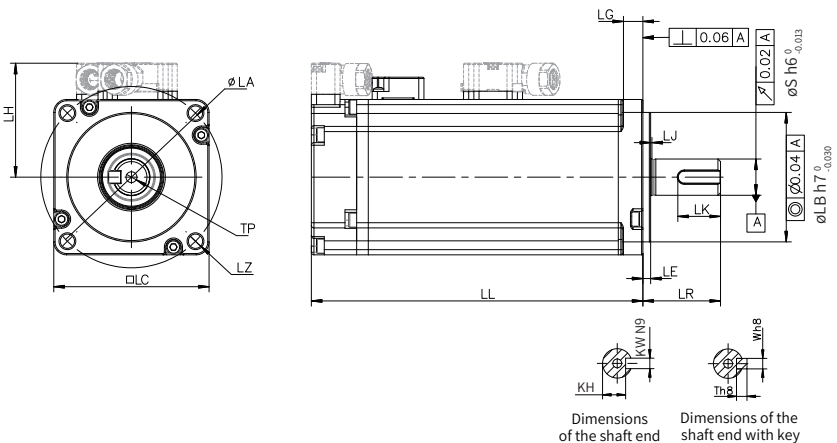

■ Lead wire-type motor

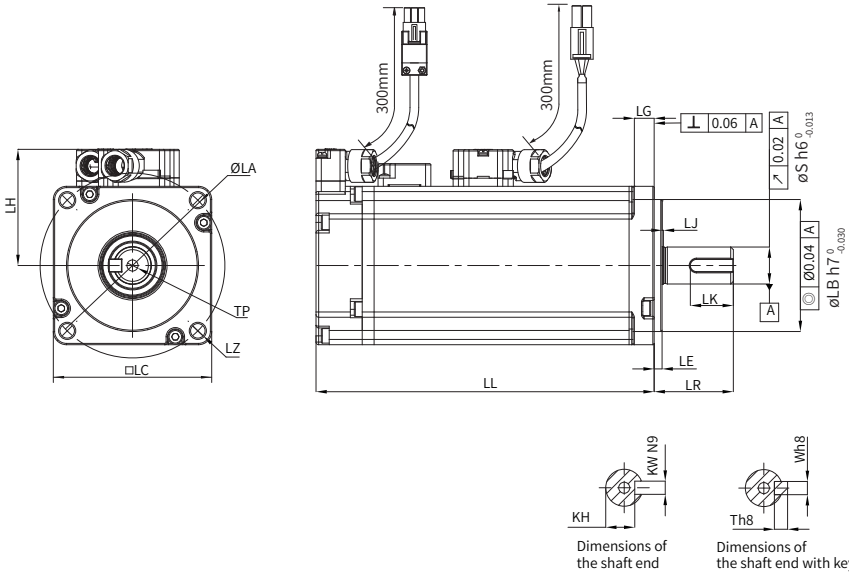

| LL | LC | LR | LA | LZ | LH | LG | LE | LJ |
|----------|----|--------|----|-----------------------------------|----|-----|-------|-------------|
| 107(140) | 80 | 35±0.5 | 90 | 4-φ7 | 54 | 7.7 | 3±0.5 | 0.5±0.35 |
| S | LB | TP | LK | KH | KW | W | T | Weight (kg) |
| 19 | 70 | M6x20 | 25 | 15.5 ⁰ _{-0.1} | 6 | 6 | 6 | 2.18 (2.82) |

2.2.8 MS1H1-10C30CB-*33*Z(-S)

| Technical Data for Motors in Flange Size 80 (mm) (Low Inertia, Small Capacity) | |
|---|------|
| Rated output (kW) | 1.0 |
| Voltage (V) | 220 |
| Rated torque (N·m) | 3.18 |
| Maximum torque (N·m) | 11.1 |
| Rated current (Arms) | 7.6 |
| Maximum current (Arms) | 28 |
| Rated speed (RPM) | 3000 |
| Maximum speed (RPM) | 6000 |
| Torque coefficient (N·m/Arms) | 0.46 |
| Rotor moment of inertia (kg·cm ²) | 1.75 |

■ Torque-Speed characteristics

- A — Continuous working area
- B — Short-term working area

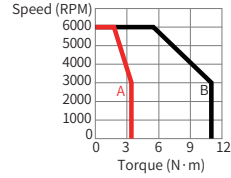

■ Heatsink-based derating curve

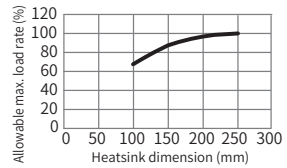

■ Allowable load

| LF (mm) | Allowable Radial Load (N) | Allowable Axial Load (N) |
|---------|---------------------------|--------------------------|
| 35 | 392 | 147 |

■ Terminal-type motor

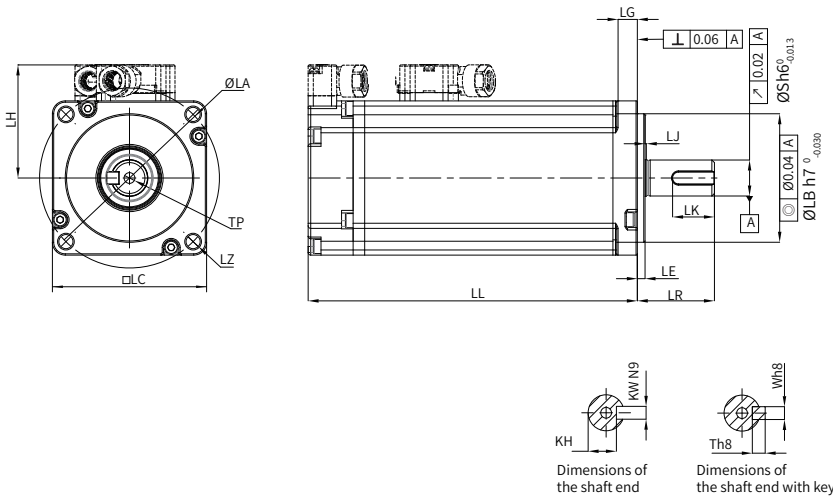

■ Lead wire-type motor

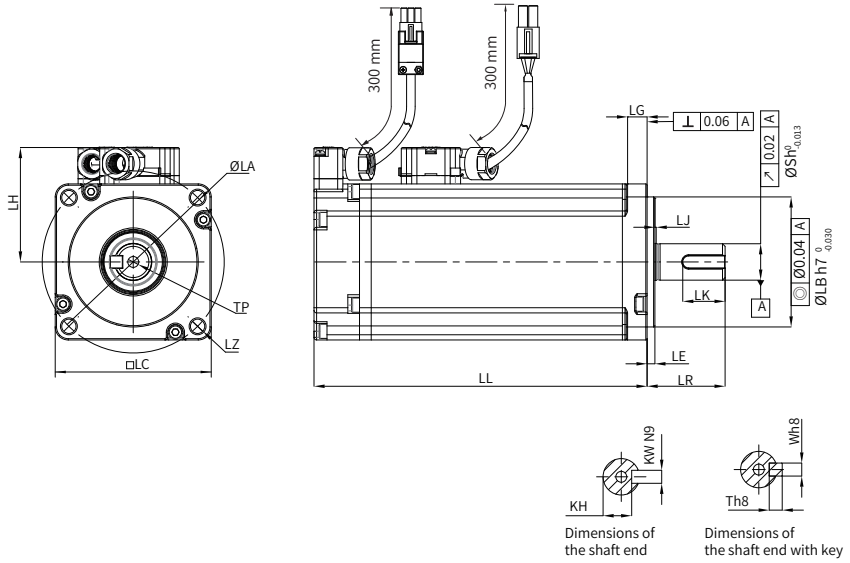

| LL | LC | LR | LA | LZ | LH | LG | LE | LJ |
|-------|----|--------|----|-----------------------------------|----|-----|-------|-------------|
| 118.2 | 80 | 35±0.5 | 90 | 4-φ7 | 54 | 7.7 | 3±0.5 | 0.5±0.35 |
| S | LB | TP | LK | KH | KW | W | T | Weight (kg) |
| 19 | 70 | M6x20 | 25 | 15.5 ⁰ _{-0.1} | 6 | 6 | 6 | 2.55 |

2.3.2 MS1H2-15C30CB-A33*Z

| Technical Data of Motors in Flange Size 100 (mm) (Low Inertia, Medium Capacity) | | |
|--|---------------------|------|
| Rated output (kW) | 1.5 | |
| Voltage (V) | 220 | |
| Rated torque (N·m) | 4.9 | |
| Maximum torque (N·m) | 14.7 | |
| Rated current (Arms) | 10.8 | |
| Maximum current (Arms) | 32 | |
| Rated speed (RPM) | 3000 | |
| Maximum speed (RPM) | 5000 | |
| Torque coefficient (N·m/Arms) | 0.54 | |
| Rotor moment of inertia (kg·cm ²) | Motor without brake | 2.46 |
| | Motor with brake | 3.71 |

■ Torque-Speed characteristics

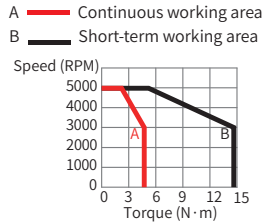

■ Heatsink-based derating curve

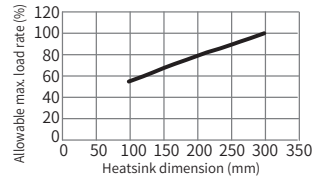

■ Electrical specifications of the motor with brake

| Holding Torque (N·m) | Supply Voltage (VDC) ±10% | Rated Power (W) | Coil Resistance (Ω) (±7%) | Exciting Current (A) | Apply Time (ms) | Release Time (ms) | Backlash (°) |
|----------------------|---------------------------|-----------------|---------------------------|----------------------|-----------------|-------------------|--------------|
| 8 | 24 | 23 | 25 | 0.96 | ≤ 85 | ≤ 30 | ≤ 0.5 |

■ Allowable load

| LF (mm) | Allowable Radial Load (N) | Allowable Axial Load (N) |
|---------|---------------------------|--------------------------|
| 45 | 686 | 196 |

■ Dimension drawing

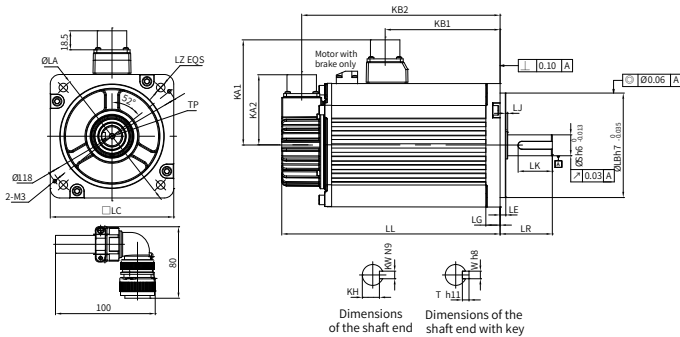

| LL | LC | LE | LA | LZ | KA1 | KA2 | LJ | KB1 | KB2 | |
|-----------|-----|-------|-------|------|---------------------------------|-----|----------|-------------|---------------|-------------|
| 189 (239) | 100 | 5±0.3 | 115 | 4-Φ7 | 88 | 74 | 2.5±0.75 | 119.5 (128) | 168.5 (219.5) | |
| LR | S | LB | TP | LK | KH | KW | W | T | LG | Weight (kg) |
| 45±1 | 24 | 95 | M8x16 | 36 | 20 ⁰ _{-0.2} | 8 | 8 | 7 | 10 | 6.22 (7.52) |

2.3.3 MS1H2-10C30CD-A33*Z

| Technical Data of Motors in Flange Size 100 (mm) (Low Inertia, Medium Capacity) | | |
|--|------------------------|------|
| Rated output (kW) | 1 | |
| Voltage (V) | 380 | |
| Rated torque (N·m) | 3.18 | |
| Maximum torque (N·m) | 9.54 | |
| Rated current (Arms) | 3.65 | |
| Maximum current (Arms) | 11 | |
| Rated speed (RPM) | 3000 | |
| Maximum speed (RPM) | 6000 | |
| Torque coefficient (N·m/Arms) | 0.89 | |
| Rotor moment of inertia (kg·cm ²) | Motor without brake | 1.87 |
| | Motor with brake | 3.12 |

■ Torque-Speed characteristics

- A — Continuous working area
- B — Short-term working area

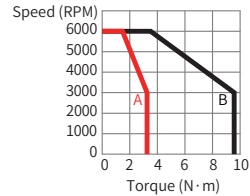

■ Heatsink-based derating curve

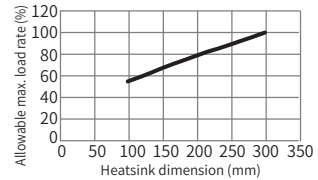

■ Electrical specifications of the motor with brake

| Holding Torque (N·m) | Supply Voltage (VDC) ±10% | Rated Power (W) | Coil Resistance (Ω) (±7%) | Exciting Current (A) | Apply Time (ms) | Release Time (ms) | Backlash (°) |
|----------------------|---------------------------|-----------------|---------------------------|----------------------|-----------------|-------------------|--------------|
| 8 | 24 | 23 | 25 | 0.96 | ≤ 85 | ≤ 30 | ≤ 0.5 |

■ Allowable load

| LF (mm) | Allowable Radial Load (N) | Allowable Axial Load (N) |
|---------|---------------------------|--------------------------|
| 45 | 686 | 196 |

■ Dimension drawing

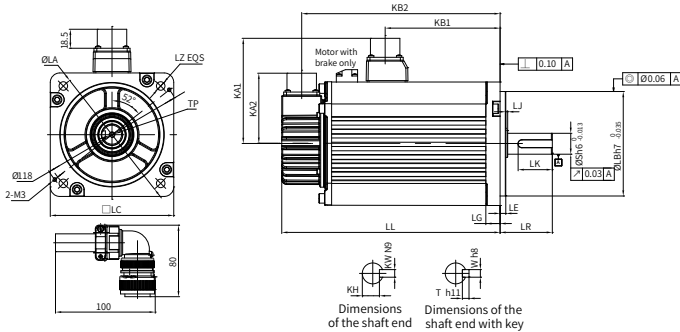

| | | | | | | | | | | |
|------------|-----|-------|-------|------|---------------------------------|-----|----------|-----------|---------------|-------------|
| LL | LC | LE | LA | LZ | KA1 | KA2 | LJ | KB1 | KB2 | |
| 164(213.5) | 100 | 5±0.3 | 115 | 4-Φ7 | 88 | 74 | 2.5±0.75 | 94.5(101) | 143.5 (192.5) | |
| LR | S | LB | TP | LK | KH | KW | W | T | LG | Weight (kg) |
| 45±1 | 24 | 95 | M8x16 | 36 | 20 ⁰ _{-0.2} | 8 | 8 | 7 | 10 | 5.11 (6.41) |

2.3.4 MS1H2-15C30CD-A33*Z

| Technical Data of Motors in Flange Size 100 (mm) (Low Inertia, Medium Capacity) | | |
|---|---------------------|------|
| Rated output (kW) | 1.5 | |
| Voltage (V) | 380 | |
| Rated torque (N·m) | 4.9 | |
| Maximum torque (N·m) | 14.7 | |
| Rated current (Arms) | 4.5 | |
| Maximum current (Arms) | 14 | |
| Rated speed (RPM) | 3000 | |
| Maximum speed (RPM) | 5000 | |
| Torque coefficient (N·m/Arms) | 1.07 | |
| Rotor moment of inertia (kg·cm ²) | Motor without brake | 2.46 |
| | Motor with brake | 3.71 |

■ Torque-Speed characteristics

A — Continuous working area
 B — Short-term working area

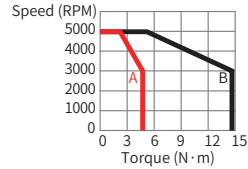

■ Heatsink-based derating curve

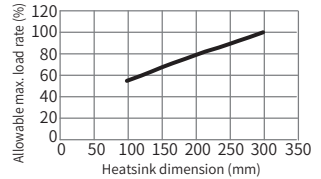

■ Electrical specifications of the motor with brake

| Holding Torque (N·m) | Supply Voltage (VDC) ±10% | Rated Power (W) | Coil Resistance (Ω) (±7%) | Exciting Current (A) | Apply Time (ms) | Release Time (ms) | Backlash (°) |
|----------------------|---------------------------|-----------------|---------------------------|----------------------|-----------------|-------------------|--------------|
| 8 | 24 | 23 | 25 | 0.96 | ≤ 85 | ≤ 30 | ≤ 0.5 |

■ Allowable load

| LF (mm) | Allowable Radial Load (N) | Allowable Axial Load (N) |
|---------|---------------------------|--------------------------|
| 45 | 686 | 196 |

■ Dimension drawing

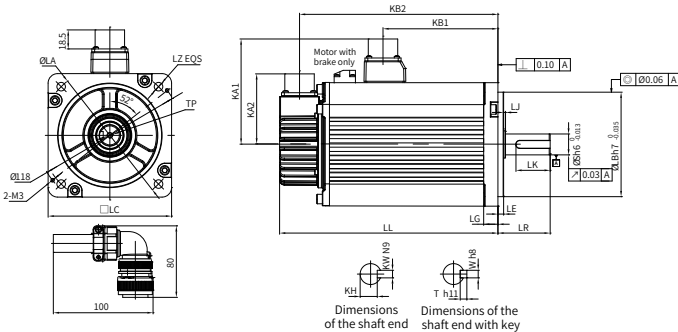

| LL | LC | LE | LA | LZ | KA1 | KA2 | LJ | KB1 | KB2 | |
|-----------|-----|-------|-------|------|---------------------------------|-----|----------|-------------|---------------|-------------|
| 189 (239) | 100 | 5±0.3 | 115 | 4-Φ7 | 88 | 74 | 2.5±0.75 | 119.5 (128) | 168.5 (219.5) | |
| LR | S | LB | TP | LK | KH | KW | W | T | LG | Weight (kg) |
| 45±1 | 24 | 95 | M8x16 | 36 | 20 ⁰ _{-0.2} | 8 | 8 | 7 | 10 | 6.22 (7.52) |

2.3.5 MS1H2-20C30CD-A331Z

| Technical Data of Motors in Flange Size 100 (mm) (Low Inertia, Medium Capacity) | |
|--|------|
| Rated output (kW) | 2 |
| Voltage (V) | 380 |
| Rated torque (N·m) | 6.36 |
| Maximum torque (N·m) | 19.1 |
| Rated current (Arms) | 5.89 |
| Maximum current (Arms) | 20 |
| Rated speed (RPM) | 3000 |
| Maximum speed (RPM) | 5000 |
| Torque coefficient (N·m/Arms) | 1.19 |
| Rotor moment of inertia (kg·cm ²) | 3.06 |

■ Torque-Speed characteristics

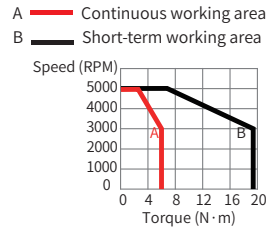

■ Heatsink-based derating curve

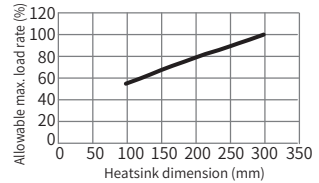

■ Allowable load

| LF (mm) | Allowable Radial Load (N) | Allowable Axial Load (N) |
|---------|---------------------------|--------------------------|
| 45 | 686 | 196 |

■ Dimension drawing

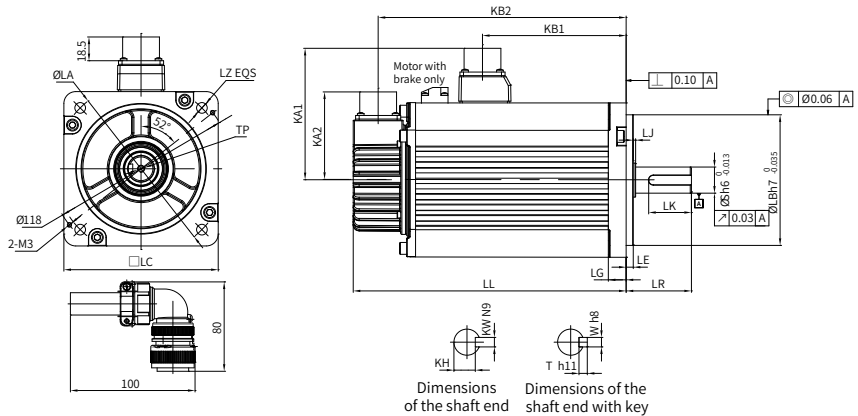

| | | | | | | | | | | |
|------|-----|-------|-------|------|---------------------------------|-----|----------|-------|-------|-------------|
| LL | LC | LE | LA | LZ | KA1 | KA2 | LJ | KB1 | KB2 | |
| 214 | 100 | 5±0.3 | 115 | 4-Φ7 | 88 | 74 | 2.5±0.75 | 144.5 | 193.5 | |
| LR | S | LB | TP | LK | KH | KW | W | T | LG | Weight (kg) |
| 45±1 | 24 | 95 | M8x16 | 36 | 20 ⁰ _{-0.2} | 8 | 8 | 7 | 10 | 7.39 |

2.3.6 MS1H2-20C30CD-A334Z-S4

| Technical Data of Motors in Flange Size 100 (mm) (Low Inertia, Medium Capacity) | |
|--|------|
| Rated output (kW) | 2 |
| Voltage (V) | 380 |
| Rated torque (N·m) | 6.36 |
| Maximum torque (N·m) | 19.1 |
| Rated current (Arms) | 5.89 |
| Maximum current (Arms) | 20 |
| Rated speed (RPM) | 3000 |
| Maximum speed (RPM) | 5000 |
| Torque coefficient (N·m/Arms) | 1.19 |
| Rotor moment of inertia (kg·cm ²) | 4.31 |

■ Torque-Speed characteristics

- A — Continuous working area
- B — Short-term working area

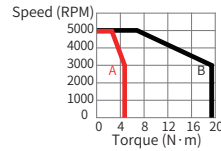

■ Heatsink-based derating curve

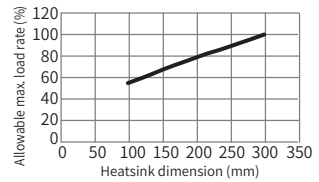

■ Electrical specifications of the motor with brake

| Holding Torque (N·m) | Supply Voltage (VDC) ±10% | Rated Power (W) | Coil Resistance (Ω (±7%)) | Exciting Current (A) | Apply Time (ms) | Release Time (ms) | Backlash (°) |
|----------------------|---------------------------|-----------------|---------------------------|----------------------|-----------------|-------------------|--------------|
| 8 | 24 | 23 | 25 | 0.96 | ≤ 85 | ≤ 30 | ≤ 0.5 |

■ Allowable load

| LF (mm) | Allowable Radial Load (N) | Allowable Axial Load (N) |
|---------|---------------------------|--------------------------|
| 45 | 686 | 196 |

■ Dimension drawing

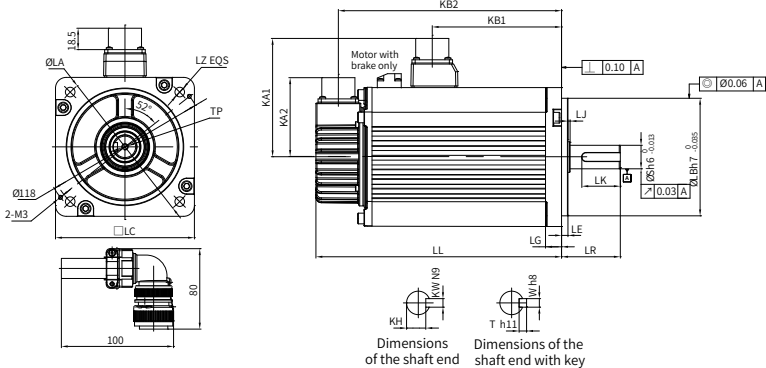

| | | | | | | | | | | |
|------|-----|-------|-------|------|---------------------------------|----------|----|----|-------------|-----|
| LL | LC | LE | LA | LZ | KA1 | KA2 | KW | LG | KB1 | KB2 |
| 265 | 100 | 5±0.3 | 115 | 4-Φ7 | 88 | 74 | 8 | 10 | 153 | 244 |
| LR | S | LB | TP | LK | KH | LJ | W | T | Weight (kg) | |
| 45±1 | 24 | 95 | M8x16 | 36 | 20 ⁰ _{-0.2} | 2.5±0.75 | 8 | 7 | 8.7 | |

2.3.7 MS1H2-25C30CD-A331Z

| Technical Data of Motors in Flange Size 100 (mm) (Low Inertia, Medium Capacity) | |
|--|------|
| Rated output (kW) | 2.5 |
| Voltage (V) | 220 |
| Rated torque (N·m) | 7.96 |
| Maximum torque (N·m) | 23.9 |
| Rated current (Arms) | 7.56 |
| Maximum current (Arms) | 25 |
| Rated speed (RPM) | 3000 |
| Maximum speed (RPM) | 5000 |
| Torque coefficient (N·m/Arms) | 1.2 |
| Rotor moment of inertia (kg·cm ²) | 3.65 |

■ Torque-Speed characteristics

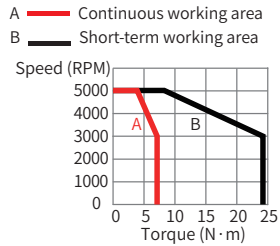

■ Heatsink-based derating curve

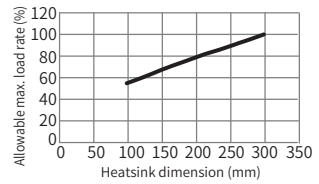

■ Allowable load

| LF (mm) | Allowable Radial Load (N) | Allowable Axial Load (N) |
|---------|---------------------------|--------------------------|
| 45 | 686 | 196 |

■ Dimension drawing

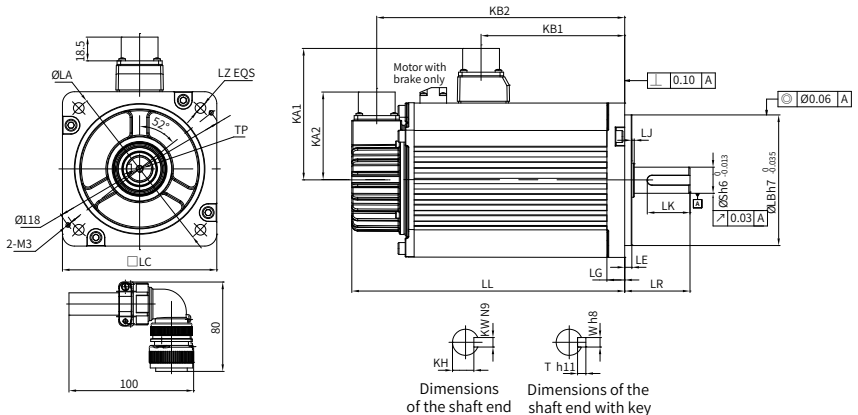

| | | | | | | | | | | |
|-------|-----|-------|-------|------|---------------------------------|----------|----|----|-------------|-------|
| LL | LC | LE | LA | LZ | KA1 | KA2 | KW | LG | KB1 | KB2 |
| 240.5 | 100 | 5±0.3 | 115 | 4-Φ7 | 88 | 74 | 8 | 10 | 169.5 | 218.5 |
| LR | S | LB | TP | LK | KH | LJ | W | T | Weight (kg) | |
| 45±1 | 24 | 95 | M8x16 | 36 | 20 ⁰ _{-0.2} | 2.5±0.75 | 8 | 7 | 8.55 | |

2.3.8 MS1H2-25C30CD-A334Z-S4

| Technical Data of Motors in Flange Size 100 (mm) (Low Inertia, Medium Capacity) | |
|--|------|
| Rated output (kW) | 2.5 |
| Voltage (V) | 220 |
| Rated torque (N·m) | 7.96 |
| Maximum torque (N·m) | 23.9 |
| Rated current (Arms) | 7.56 |
| Maximum current (Arms) | 25 |
| Rated speed (RPM) | 3000 |
| Maximum speed (RPM) | 5000 |
| Torque coefficient (N·m/Arms) | 1.2 |
| Rotor moment of inertia (kg·cm ²) | 4.9 |

■ Torque-Speed characteristics

- A — Continuous working area
- B — Short-term working area

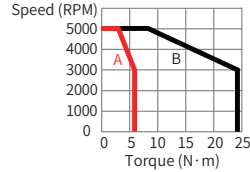

■ Heatsink-based derating curve

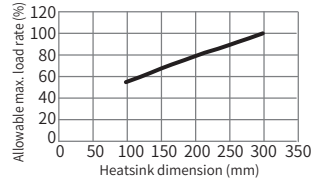

■ Electrical specifications of the motor with brake

| Holding Torque (N·m) | Supply Voltage (VDC) ±10% | Rated Power (W) | Coil Resistance (Ω) (±7%) | Exciting Current (A) | Apply Time (ms) | Release Time (ms) | Backlash (°) |
|----------------------|---------------------------|-----------------|---------------------------|----------------------|-----------------|-------------------|--------------|
| 8 | 24 | 23 | 25 | 0.96 | ≤ 85 | ≤ 30 | ≤ 0.5 |

■ Allowable load

| LF (mm) | Allowable Radial Load (N) | Allowable Axial Load (N) |
|---------|---------------------------|--------------------------|
| 45 | 686 | 196 |

■ Dimension drawing

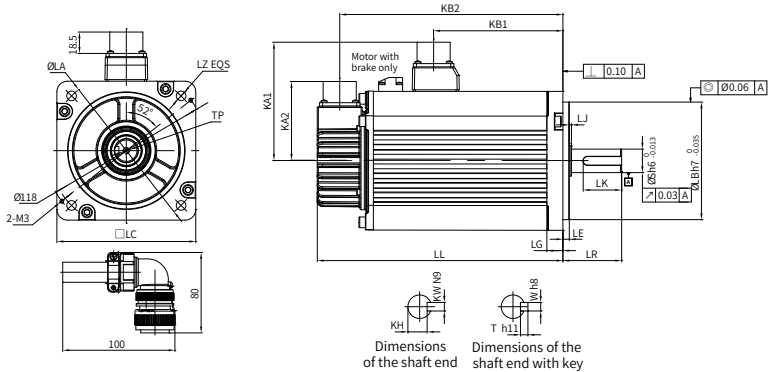

| | | | | | | | | | | | |
|------|-----|-------|-----|-------|-----|---------------------------------|----------|----|-----|-------------|--|
| LL | LC | LE | LA | LZ | KA1 | KA2 | KW | LG | KB1 | KB2 | |
| 290 | 100 | 5±0.3 | 115 | 4-Φ7 | 88 | 74 | 8 | 10 | 178 | 269 | |
| LR | S | | LB | TP | LK | KH | LJ | W | T | Weight (kg) | |
| 45±1 | 24 | | 95 | M8x16 | 36 | 20 ⁰ _{-0.2} | 2.5±0.75 | 8 | 7 | 9.8 | |

2.3.9 MS1H2-30C30CD-A331Z

| Technical Data of Motors in Flange Size 130 (mm) (Low Inertia, Medium Capacity) | |
|--|------|
| Rated output (kW) | 3 |
| Voltage (V) | 380 |
| Rated torque (N·m) | 9.8 |
| Maximum torque (N·m) | 29.4 |
| Rated current (Arms) | 10 |
| Maximum current (Arms) | 30 |
| Rated speed (RPM) | 3000 |
| Maximum speed (RPM) | 5000 |
| Torque coefficient (N·m/Arms) | 1.2 |
| Rotor moment of inertia (kg·cm ²) | 7.72 |

■ Torque-Speed characteristics

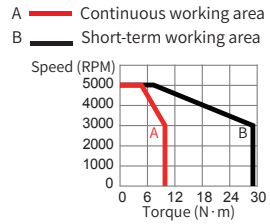

■ Heatsink-based derating curve

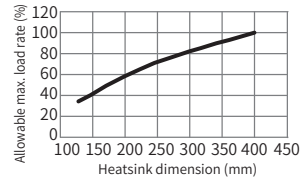

■ Allowable load

| LF (mm) | Allowable Radial Load (N) | Allowable Axial Load (N) |
|---------|---------------------------|--------------------------|
| 63 | 980 | 392 |

■ Dimension drawing

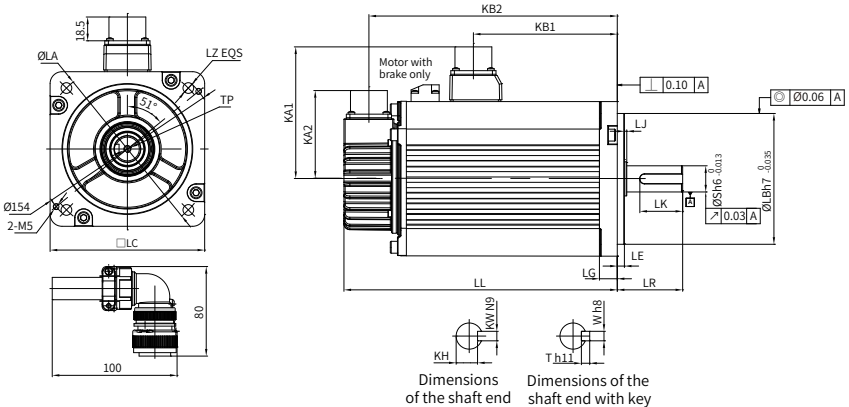

| | | | | | | | | | | |
|-------|-----|-------|-------|------|---------------------------------|----------|----|----|-------------|-------|
| LL | LC | LE | LA | LZ | KA1 | KA2 | KW | LG | KB1 | KB2 |
| 209.5 | 130 | 6±0.3 | 145 | 4-Φ9 | 103 | 74 | 8 | 14 | 136 | 188.5 |
| LR | S | LB | TP | LK | KH | LJ | W | T | Weight (kg) | |
| 63±1 | 28 | 110 | M8x20 | 54 | 24 ⁰ _{-0.2} | 0.5±0.75 | 8 | 7 | 10.73 | |

2.3.10 MS1H2-30C30CD-A334Z-S4

| Technical Data of Motors in Flange Size 130 (mm) (Low Inertia, Medium Capacity) | |
|--|-------|
| Rated output (kW) | 3 |
| Voltage (V) | 380 |
| Rated torque (N·m) | 9.8 |
| Maximum torque (N·m) | 29.4 |
| Rated current (Arms) | 10 |
| Maximum current (Arms) | 30 |
| Rated speed (RPM) | 3000 |
| Maximum speed (RPM) | 5000 |
| Torque coefficient (N·m/Arms) | 1.2 |
| Rotor moment of inertia (kg·cm ²) | 10.22 |

■ Torque-Speed characteristics

- A — Continuous working area
- B — Short-term working area

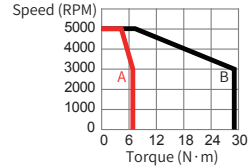

■ Heatsink-based derating curve

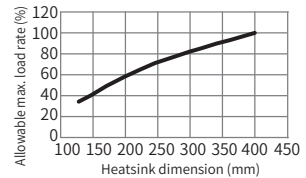

■ Electrical specifications of the motor with brake

| Holding Torque (N·m) | Supply Voltage (VDC) ±10% | Rated Power (W) | Coil Resistance (Ω) (±7%) | Exciting Current (A) | Apply Time (ms) | Release Time (ms) | Backlash (°) |
|----------------------|---------------------------|-----------------|---------------------------|----------------------|-----------------|-------------------|--------------|
| 16 | 24 | 27 | 21.3 | 1.13 | ≤ 100 | ≤ 60 | ≤ 0.5 |

■ Allowable load

| LF (mm) | Allowable Radial Load (N) | Allowable Axial Load (N) |
|---------|---------------------------|--------------------------|
| 63 | 980 | 392 |

■ Dimension drawing

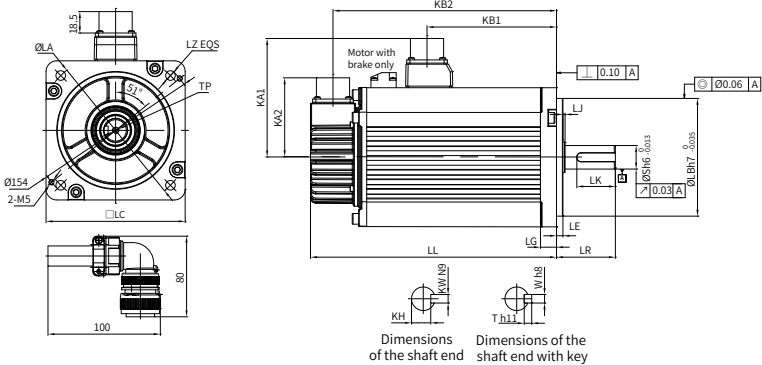

| | | | | | | | | | | |
|-------|-----|-------|-------|------|--------------------------------|----------|----|----|-------------|-------|
| LL | LC | LE | LA | LZ | KA1 | KA2 | KW | LG | KB1 | KB2 |
| 265.5 | 130 | 6±0.3 | 145 | 4-Φ9 | 103 | 74 | 8 | 14 | 139 | 244.5 |
| LR | S | LB | TP | LK | KH | LJ | W | T | Weight (kg) | |
| 63±1 | 28 | 110 | M8x20 | 54 | 24 ⁰ _{0.2} | 0.5±0.75 | 8 | 7 | 13.2 | |

2.3.11 MS1H2-40C30CD-A331Z

| Technical Data for Motors in Flange Size 130 (mm) (Low Inertia, Medium Capacity) | |
|---|------|
| Rated output (kW) | 4 |
| Voltage (V) | 380 |
| Rated torque (N·m) | 12.6 |
| Maximum torque (N·m) | 37.8 |
| Rated current (Arms) | 13.6 |
| Maximum current (Arms) | 40.8 |
| Rated speed (RPM) | 3000 |
| Maximum speed (RPM) | 5000 |
| Torque coefficient (N·m/Arms) | 1.12 |
| Rotor moment of inertia (kg·cm ²) | 12.1 |

■ Torque-Speed characteristics

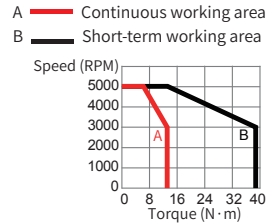

■ Heatsink-based derating curve

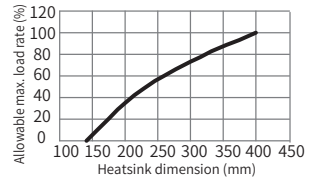

■ Allowable load

| LF (mm) | Allowable Radial Load (N) | Allowable Axial Load (N) |
|---------|---------------------------|--------------------------|
| 63 | 1176 | 392 |

■ Dimension drawing

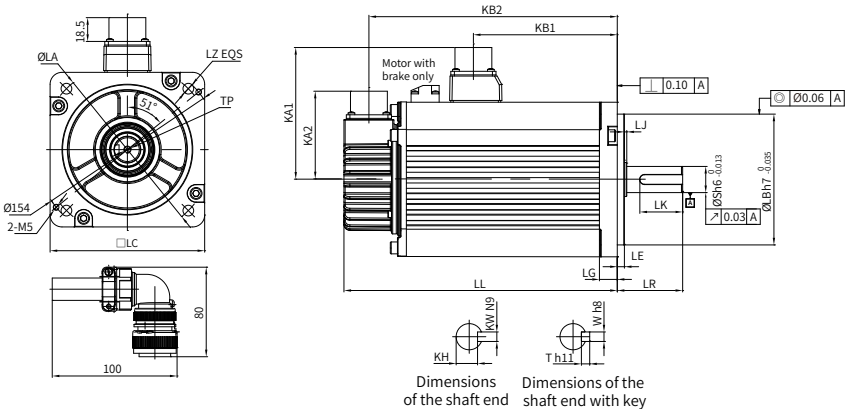

| LL | LC | LE | LA | LZ | KA1 | KA2 | KW | LG | KB1 | KB2 |
|------|-----|-------|-------|------|---------------------------------|----------|----|----|-------------|-----|
| 252 | 130 | 6±0.3 | 145 | 4-Φ9 | 103 | 74 | 8 | 14 | 178.5 | 231 |
| LR | S | LB | TP | LK | KH | LJ | W | T | Weight (kg) | |
| 63±1 | 28 | 110 | M8x20 | 54 | 24 ⁰ _{-0.2} | 0.5±0.75 | 8 | 7 | 15.43 | |

2.3.12 MS1H2-40C30CD-A334Z-S4

| Technical Data of Motors in Flange Size 130 (mm) (Low Inertia, Medium Capacity) | |
|--|------|
| Rated output (kW) | 4 |
| Voltage (V) | 380 |
| Rated torque (N·m) | 12.6 |
| Maximum torque (N·m) | 37.8 |
| Rated current (Arms) | 13.6 |
| Maximum current (Arms) | 40.8 |
| Rated speed (RPM) | 3000 |
| Maximum speed (RPM) | 5000 |
| Torque coefficient (N·m/Arms) | 1.12 |
| Rotor moment of inertia (kg·cm ²) | 14.6 |

■ Torque-Speed characteristics

- A — Continuous working area
- B — Short-term working area

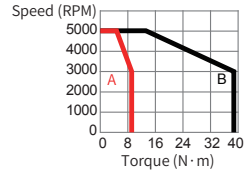

■ Heatsink-based derating curve

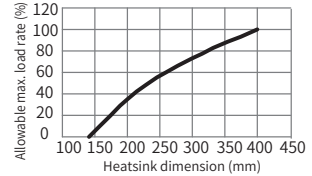

■ Electrical specifications of the motor with brake

| Holding Torque (N·m) | Supply Voltage (VDC) ±10% | Rated Power (W) | Coil Resistance (Ω) (±7%) | Exciting Current (A) | Apply Time (ms) | Release Time (ms) | Backlash (°) |
|----------------------|---------------------------|-----------------|---------------------------|----------------------|-----------------|-------------------|--------------|
| 16 | 24 | 27 | 21.3 | 1.13 | ≤ 100 | ≤ 60 | ≤ 0.5 |

■ Allowable load

| LF (mm) | Allowable Radial Load (N) | Allowable Axial Load (N) |
|---------|---------------------------|--------------------------|
| 63 | 1176 | 392 |

■ Dimension drawing

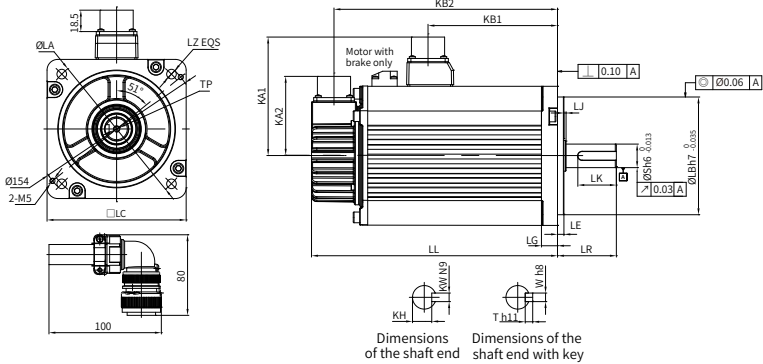

| | | | | | | | | | | |
|------|-----|-------|-------|------|---------------------------------|----------|----|----|-------------|-----|
| LL | LC | LE | LA | LZ | KA1 | KA2 | KW | LG | KB1 | KB2 |
| 308 | 130 | 6±0.3 | 145 | 4-Φ9 | 103 | 74 | 8 | 14 | 181.5 | 287 |
| LR | S | LB | TP | LK | KH | LJ | W | T | Weight (kg) | |
| 63±1 | 28 | 110 | M8x20 | 54 | 24 ⁰ _{-0.2} | 0.5±0.75 | 8 | 7 | 17.9 | |

2.3.14 MS1H2-50C30CD-A334Z-S4

| Technical Data of Motors in Flange Size 130 (mm) (Low Inertia, Medium Capacity) | |
|--|------|
| Rated output (kW) | 5 |
| Voltage (V) | 380 |
| Rated torque (N·m) | 15.8 |
| Maximum torque (N·m) | 47.6 |
| Rated current (Arms) | 16 |
| Maximum current (Arms) | 48 |
| Rated speed (RPM) | 3000 |
| Maximum speed (RPM) | 5000 |
| Torque coefficient (N·m/Arms) | 1.29 |
| Rotor moment of inertia (kg·cm ²) | 17.9 |

■ Torque-Speed characteristics

- A — Continuous working area
- B — Short-term working area

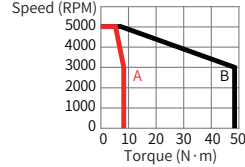

■ Heatsink-based derating curve

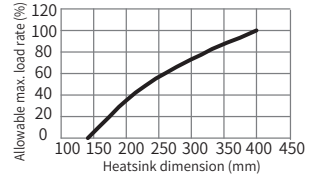

■ Electrical specifications of the motor with brake

| Holding Torque (N·m) | Supply Voltage (VDC) ±10% | Rated Power (W) | Coil Resistance (Ω) (±7%) | Exciting Current (A) | Apply Time (ms) | Release Time (ms) | Backlash (°) |
|----------------------|---------------------------|-----------------|---------------------------|----------------------|-----------------|-------------------|--------------|
| 16 | 24 | 27 | 21.3 | 1.13 | ≤ 100 | ≤ 60 | ≤ 0.5 |

■ Allowable load

| LF (mm) | Allowable Radial Load (N) | Allowable Axial Load (N) |
|---------|---------------------------|--------------------------|
| 63 | 1176 | 392 |

■ Dimension drawing

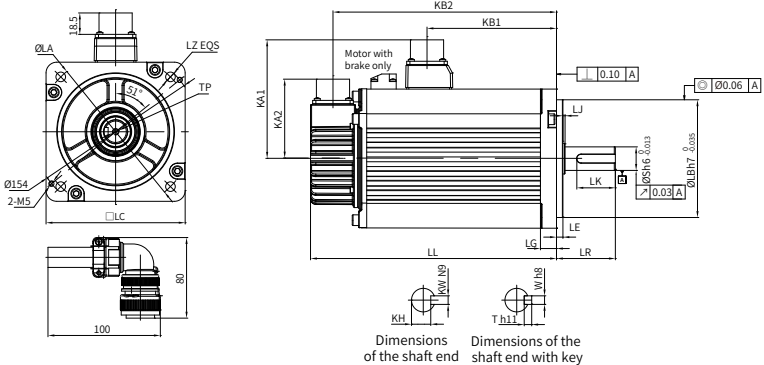

| | | | | | | | | | | |
|-------|-----|-------|-------|------|---------|----------|----|----|-------------|-------|
| LL | LC | LE | LA | LZ | KA1 | KA2 | KW | LG | KB1 | KB2 |
| 350.5 | 130 | 6±0.3 | 145 | 4-Φ9 | 103 | 74 | 8 | 14 | 224 | 329.5 |
| LR | S | LB | TP | LK | KH | LJ | W | T | Weight (kg) | |
| 63±1 | 28 | 110 | M8x20 | 54 | 24 ±0.2 | 0.5±0.75 | 8 | 7 | 18.4 | |

2.4 Motors with Medium Inertia and Small Capacity (MS1H4)

2.4.1 MS1H4-40B30CB-*33*Z(-S)

| Technical Data of Motors in Flange Size 60 (mm) (Medium Inertia, Small Capacity) | | |
|---|---------------------|-------|
| Rated output (kW) | 0.4 | |
| Voltage (V) | 220 | |
| Rated torque (N·m) | 1.27 | |
| Maximum torque (N·m) | 4.46 | |
| Rated current (Arms) | 2.8 | |
| Maximum current (Arms) | 10.1 | |
| Rated speed (RPM) | 3000 | |
| Maximum speed (RPM) | 6000 | |
| Torque coefficient (N·m/Arms) | 0.53 | |
| Rotor moment of inertia (kg·cm ²) | Motor without brake | 0.657 |
| | Motor with brake | 0.667 |

■ Torque-Speed characteristics

A — Continuous working area

B — Short-term working area

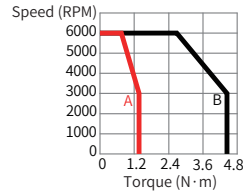

■ Heatsink-based derating curve

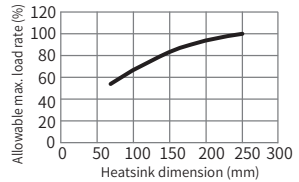

■ Electrical specifications of the motor with brake

| Holding Torque (N·m) | Supply Voltage (VDC) ±10% | Rated Power (W) | Coil Resistance (Ω) (±7%) | Exciting Current (A) | Apply Time (ms) | Release Time (ms) | Backlash (°) |
|----------------------|---------------------------|-----------------|---------------------------|----------------------|-----------------|-------------------|--------------|
| 1.5 | 24 | 7.6 | 75.79 | 0.32 | ≤ 60 | ≤ 20 | ≤ 1.5 |

■ Allowable load

| LF (mm) | Allowable Radial Load (N) | Allowable Axial Load (N) |
|---------|---------------------------|--------------------------|
| 25 | 245 | 74 |

■ Terminal-type motor

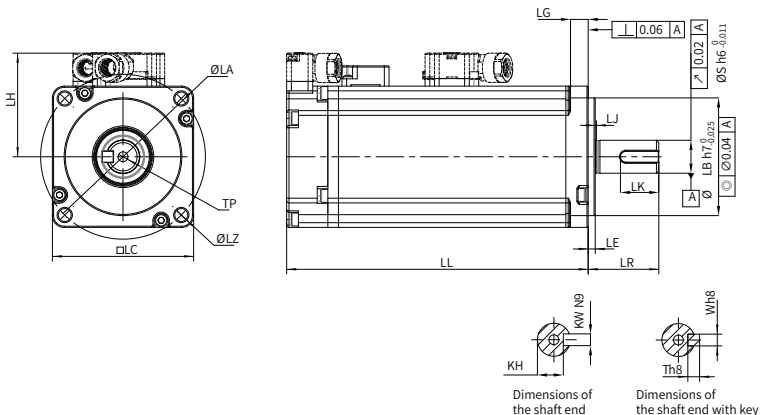

Dimensions of the shaft end

Dimensions of the shaft end with key

■ Lead wire-type motor

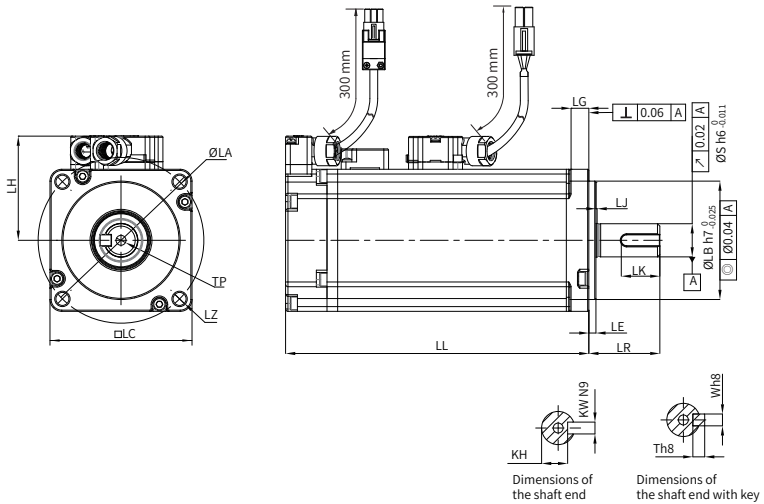

| LL | LC | LR | LA | LZ | LH | LG | LE | LJ |
|-----------|----|--------|------|---------------------------------|----|-----|-------|-------------|
| 105 (128) | 60 | 30±0.5 | 70 | 4-φ5.5 | 44 | 7.5 | 3±0.5 | 0.5±0.35 |
| S | LB | TP | LK | KH | KW | W | T | Weight (kg) |
| 14 | 50 | M5x8 | 16.5 | 11 ⁰ _{-0.1} | 5 | 5 | 5 | 1.27 (1.62) |

2.4.2 MS1H4-75B30CB-*33*Z(-S)

| Technical Data of Motors in Flange Size 80 (mm) (Medium Inertia, Small Capacity) | | |
|---|---------------------|-------|
| Rated output (kW) | 0.75 | |
| Voltage (V) | 220 | |
| Rated torque (N·m) | 2.39 | |
| Maximum torque (N·m) | 8.36 | |
| Rated current (Arms) | 4.8 | |
| Maximum current (Arms) | 16.9 | |
| Rated speed (RPM) | 3000 | |
| Maximum speed (RPM) | 6000 | |
| Torque coefficient (N·m/Arms) | 0.58 | |
| Rotor moment of inertia (kg·cm ²) | Motor without brake | 2 |
| | Motor with brake | 2.012 |

■ Torque-Speed characteristics

A — Continuous working area
B — Short-term working area

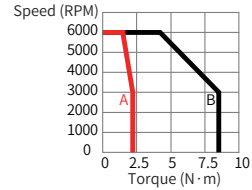

■ Heatsink-based derating curve

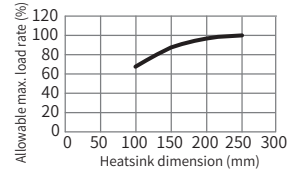

■ Electrical specifications of the motor with brake

| Holding Torque (N·m) | Supply Voltage ±10% (VDC) | Rated Power (W) | Coil Resistance (Ω) (±7%) | Exciting Current (A) | Apply Time (ms) | Release Time (ms) | Backlash (°) |
|----------------------|---------------------------|-----------------|---------------------------|----------------------|-----------------|-------------------|--------------|
| 3.2 | 24 | 10 | 57.6 | 0.42 | ≤ 60 | ≤ 40 | ≤ 1.0 |

■ Allowable load

| LF (mm) | Allowable Radial Load (N) | Allowable Axial Load (N) |
|---------|---------------------------|--------------------------|
| 35 | 392 | 147 |

■ Terminal-type motor

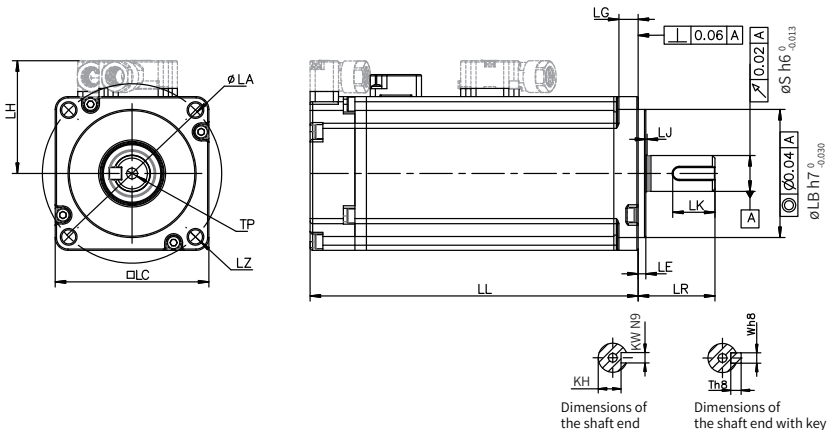

■ Lead wire-type motor

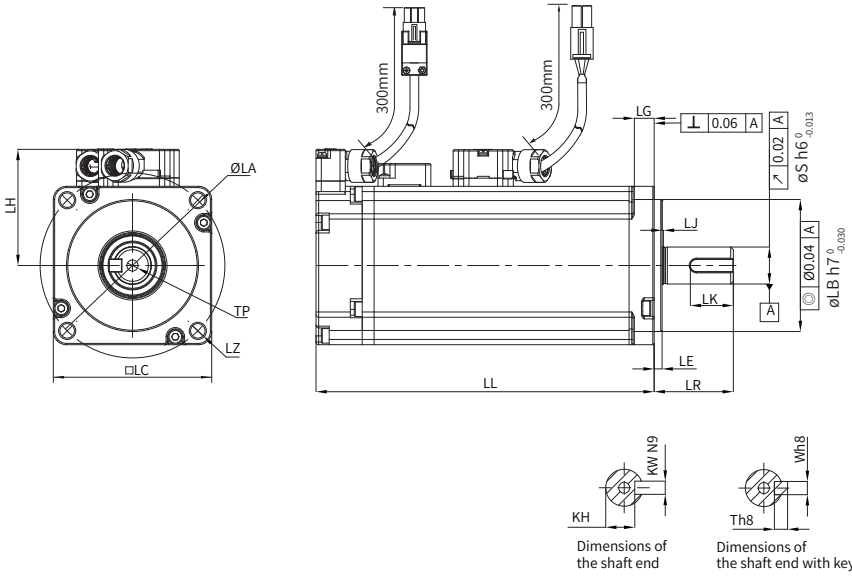

| | | | | | | | | |
|--------------|----|--------|----|-----------------------------------|----|-----|-------|-------------|
| LL | LC | LR | LA | LZ | LH | LG | LE | LJ |
| 117.5(147.5) | 80 | 35±0.5 | 90 | 4-φ7 | 54 | 7.7 | 3±0.5 | 0.5±0.35 |
| S | LB | TP | LK | KH | KW | W | T | Weight (kg) |
| 19 | 70 | M6x20 | 25 | 15.5 ⁰ _{-0.1} | 6 | 6 | 6 | 2.40 (3.04) |

2.5 Motors with Medium Inertia and Medium Capacity (MS1H3)

2.5.1 MS1H3-85B15CB-*33*Z

| Technical Data of Motors in Flange Size 130 (mm) (Medium Inertia, Medium Capacity) | | |
|---|---------------------|------|
| Rated output (kW) | 0.85 | |
| Voltage (V) | 220 | |
| Rated torque (N·m) | 5.39 | |
| Maximum torque (N·m) | 13.5 | |
| Rated current (Arms) | 6.6 | |
| Maximum current (Arms) | 16.5 | |
| Rated speed (RPM) | 1500 | |
| Maximum speed (RPM) | 3000 | |
| Torque coefficient (N·m/Arms) | 0.95 | |
| Rotor moment of inertia (kg·cm ²) | Motor without brake | 13.3 |
| | Motor with brake | 14 |

■ Torque-Speed characteristics

- A — Continuous working area
- B — Short-term working area

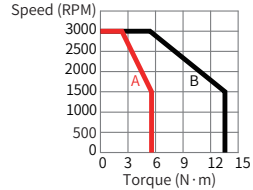

■ Heatsink-based derating curve

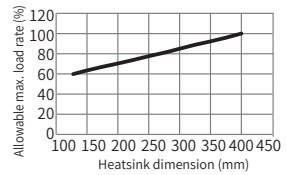

■ Electrical specifications of the motor with brake

| Holding Torque (N·m) | Supply Voltage (VDC) ±10% | Rated Power (W) | Coil Resistance (Ω) (±7%) | Exciting Current (A) | Apply Time (ms) | Release Time (ms) | Backlash (°) |
|----------------------|---------------------------|-----------------|---------------------------|----------------------|-----------------|-------------------|--------------|
| 12 | 24 | 19.4 | 29.7 | 0.81 | ≤ 120 | ≤ 60 | ≤ 0.5 |

■ Allowable load

| LF (mm) | Allowable Radial Load (N) | Allowable Axial Load (N) |
|---------|---------------------------|--------------------------|
| 45 | 686 | 196 |

■ Dimension drawing

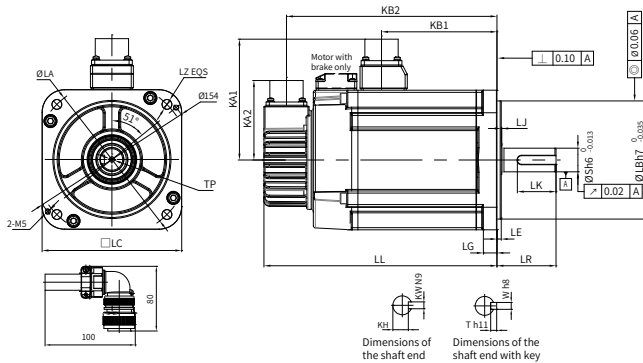

| | | | | | | | | | | | |
|-----------|-----|-----|-------|------|---------------------------------|----------|-----|-----------|----|-------------|--|
| LL | LC | LE | LA | LZ | KA1 | KB1 | KA2 | KB2 | LG | KW | |
| 146 (182) | 130 | 4 | 145 | 4-Φ9 | 103 | 72.5 | 74 | 125 (161) | 14 | 8 | |
| LR | S | LB | TP | LK | KH | LJ | | W | T | Weight (kg) | |
| 55±1 | 22 | 110 | M6x20 | 36 | 18 ⁰ _{-0.2} | 0.5±0.75 | | 8 | 7 | 7 (8) | |

2.5.2 MS1H3-13C15CB-*33*Z

| Technical Data of Motors in Flange Size 130 (mm) (Medium Inertia, Medium Capacity) | | |
|---|---------------------|------|
| Rated output (kW) | 1.3 | |
| Voltage (V) | 220 | |
| Rated torque (N·m) | 8.34 | |
| Maximum torque (N·m) | 20.85 | |
| Rated current (Arms) | 10 | |
| Maximum current (Arms) | 25 | |
| Rated speed (RPM) | 1500 | |
| Maximum speed (RPM) | 3000 | |
| Torque coefficient (N·m/Arms) | 0.95 | |
| Rotor moment of inertia (kg·cm ²) | Motor without brake | 17.8 |
| | Motor with brake | 18.5 |

■ Torque-Speed characteristics

A — Continuous working area
 B — Short-term working area

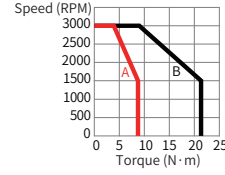

■ Heatsink-based derating curve

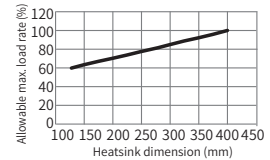

■ Electrical specifications of the motor with brake

| Holding Torque (N·m) | Supply Voltage (VDC) | Rated Power (W) | Coil Resistance (Ω) (±7%) | Exciting Current (A) | Apply Time (ms) | Release Time (ms) | Backlash (°) |
|----------------------|----------------------|-----------------|---------------------------|----------------------|-----------------|-------------------|--------------|
| 12 | 24 ±10% | 19.4 | 29.7 | 0.81 | ≤ 120 | ≤ 60 | ≤ 0.5 |

■ Allowable load

| LF (mm) | Allowable Radial Load (N) | Allowable Axial Load (N) |
|---------|---------------------------|--------------------------|
| 45 | 686 | 196 |

■ Dimension drawing

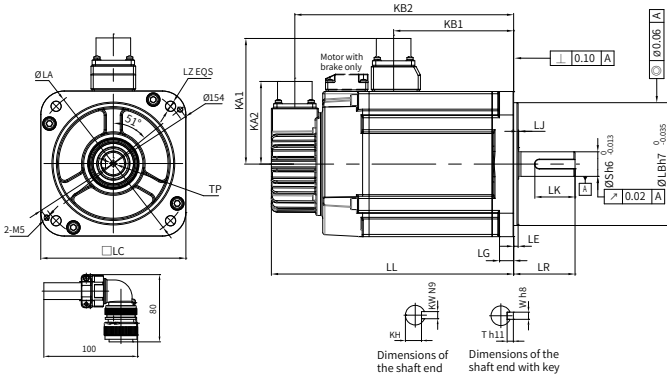

| | | | | | | | | | | |
|-----------|-----|-----|-------|------|---------------------------------|----------|-----|-----------|-------------|----|
| LL | LC | LE | LA | LZ | KA1 | KB1 | KA2 | KB2 | LG | KW |
| 163 (199) | 130 | 4 | 145 | 4-Φ9 | 103 | 89.5 | 74 | 142 (178) | 14 | 8 |
| LR | S | LB | TP | LK | KH | LJ | W | T | Weight (kg) | |
| 55±1 | 22 | 110 | M6x20 | 36 | 18 ⁰ _{-0.2} | 0.5±0.75 | 8 | 7 | 8 (9.5) | |

2.5.3 MS1H3-85B15CD-*33*Z

| Technical Data of Motors in Flange Size 130 (mm) (Medium Inertia, Medium Capacity) | | |
|---|---------------------|------|
| Rated output (kW) | 0.85 | |
| Voltage (V) | 380 | |
| Rated torque (N·m) | 5.39 | |
| Maximum torque (N·m) | 13.5 | |
| Rated current (Arms) | 3.3 | |
| Maximum current (Arms) | 8.25 | |
| Rated speed (RPM) | 1500 | |
| Maximum speed (RPM) | 3000 | |
| Torque coefficient (N·m/Arms) | 1.87 | |
| Rotor moment of inertia (kg·cm ²) | Motor without brake | 13.3 |
| | Motor with brake | 14 |

■ Torque-Speed characteristics

- A — Continuous working area
- B — Short-term working area

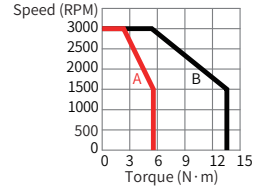

■ Heatsink-based derating curve

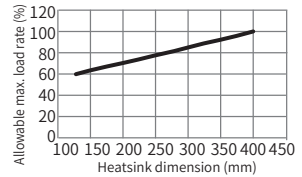

■ Electrical specifications of the motor with brake

| Holding Torque (N·m) | Supply Voltage (VDC) ±10% | Rated Power (W) | Coil Resistance (Ω) (±7%) | Exciting Current (A) | Apply Time (ms) | Release Time (ms) | Backlash (°) |
|----------------------|---------------------------|-----------------|---------------------------|----------------------|-----------------|-------------------|--------------|
| 12 | 24 | 19.4 | 29.7 | 0.81 | ≤ 120 | ≤ 60 | ≤ 0.5 |

■ Allowable load

| LF (mm) | Allowable Radial Load (N) | Allowable Axial Load (N) |
|---------|---------------------------|--------------------------|
| 45 | 686 | 196 |

■ Dimension drawing

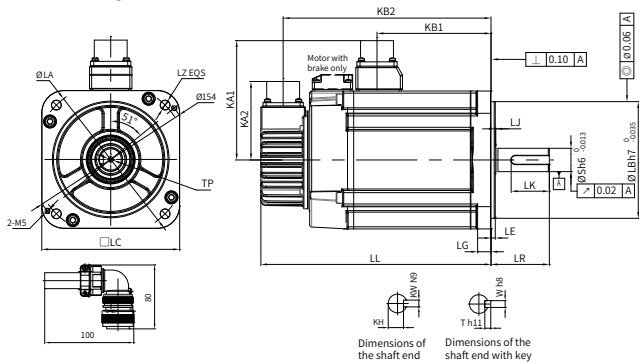

| LL | LC | LE | LA | LZ | KA1 | KB1 | KA2 | KB2 | LG | KW | |
|-----------|-----|-----|-------|------|---------------------------------|----------|-----|-----------|----|-------|-------------|
| 146 (182) | 130 | 4 | 145 | 4-Φ9 | 103 | 72.5 | 74 | 125 (161) | 14 | T | Weight (kg) |
| LR | S | LB | TP | LK | KH | LJ | | W | 7 | 7 (8) | |
| 55±1 | 22 | 110 | M6x20 | 36 | 18 ⁰ _{-0.2} | 0.5±0.75 | | 8 | | | |

2.5.4 MS1H3-13C15CD-*33*Z

| Technical Data for Motors in Flange Size 130 (mm) (Medium Inertia, Medium Capacity) | | |
|--|---------------------|------|
| Rated output (kW) | 1.3 | |
| Voltage (V) | 380 | |
| Rated torque (N·m) | 8.34 | |
| Maximum torque (N·m) | 20.85 | |
| Rated current (Arms) | 5 | |
| Maximum current (Arms) | 12.5 | |
| Rated speed (RPM) | 1500 | |
| Maximum speed (RPM) | 3000 | |
| Torque coefficient (N·m/Arms) | 1.87 | |
| Rotor moment of inertia (kg·cm ²) | Motor without brake | 17.8 |
| | Motor with brake | 18.5 |

■ Torque-Speed characteristics

A — Continuous working area
B — Short-term working area

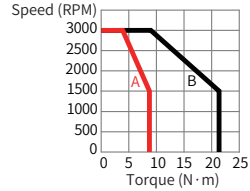

■ Heatsink-based derating curve

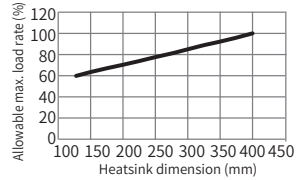

■ Electrical specifications of the motor with brake

| Holding Torque (N·m) | Supply Voltage (VDC) ±10% | Rated Power (W) | Coil Resistance (Ω) (±7%) | Exciting Current (A) | Apply Time (ms) | Release Time (ms) | Backlash (°) |
|----------------------|---------------------------|-----------------|---------------------------|----------------------|-----------------|-------------------|--------------|
| 12 | 24 | 19.4 | 29.7 | 0.81 | ≤ 120 | ≤ 60 | ≤ 0.5 |

■ Allowable load

| LF (mm) | Allowable Radial Load (N) | Allowable Axial Load (N) |
|---------|---------------------------|--------------------------|
| 45 | 686 | 196 |

■ Dimension drawing

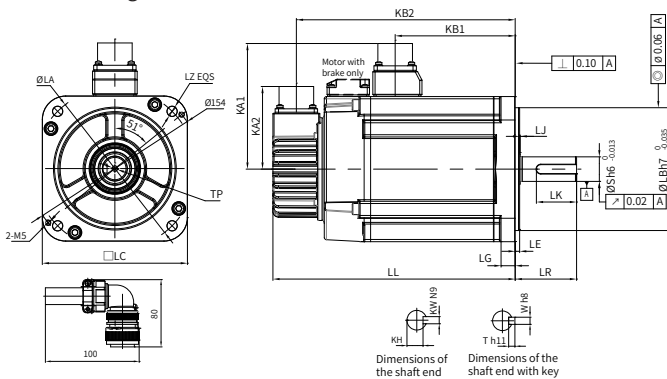

| LL | LC | LE | LA | LZ | KA1 | KB1 | KA2 | KB2 | LG | KW | |
|-----------|-----|-----|-------|------|---------------------------------|----------|-----|-----------|----|-------------|--|
| 163 (199) | 130 | 4 | 145 | 4-Φ9 | 103 | 89.5 | 74 | 142 (178) | 14 | 8 | |
| LR | S | LB | TP | LK | KH | LJ | | W | T | Weight (kg) | |
| 55±1 | 22 | 110 | M6x20 | 36 | 18 ⁰ _{-0.2} | 0.5±0.75 | | 8 | 7 | 8 (9.5) | |

2.5.5 MS1H3-18C15CD-*33*Z

| Technical Data of Motors in Flange Size 130 (mm) (Medium Inertia, Medium Capacity) | | |
|---|------------------------|------|
| Rated output (kW) | 1.8 | |
| Voltage (V) | 380 | |
| Rated torque (N·m) | 11.5 | |
| Maximum torque (N·m) | 28.75 | |
| Rated current (Arms) | 6.6 | |
| Maximum current (Arms) | 16.5 | |
| Rated speed (RPM) | 1500 | |
| Maximum speed (RPM) | 3000 | |
| Torque coefficient (N·m/Arms) | 1.87 | |
| Rotor moment of inertia (kg·cm ²) | Motor without brake | 25 |
| | Motor with brake | 25.7 |

■ Torque-Speed characteristics

- A — Continuous working area
- B — Short-term working area

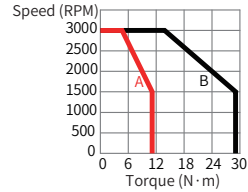

■ Heatsink-based derating curve

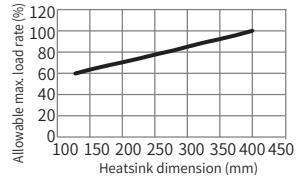

■ Electrical specifications of the motor with brake

| Holding Torque (N·m) | Supply Voltage (VDC) ±10% | Rated Power (W) | Coil Resistance (Ω) (±7%) | Exciting Current (A) | Apply Time (ms) | Release Time (ms) | Backlash (°) |
|----------------------|---------------------------|-----------------|---------------------------|----------------------|-----------------|-------------------|--------------|
| 12 | 24 | 19.4 | 29.7 | 0.81 | ≤ 120 | ≤ 60 | ≤ 0.5 |

■ Allowable load

| LF (mm) | Allowable Radial Load (N) | Allowable Axial Load (N) |
|---------|---------------------------|--------------------------|
| 45 | 686 | 196 |

■ Dimension drawing

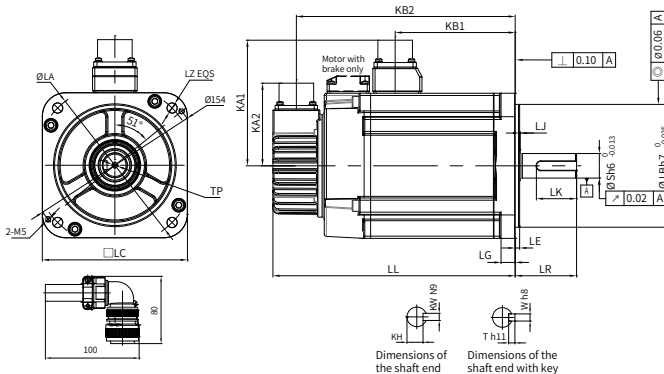

| LL | LC | LE | LA | LZ | KA1 | KB1 | KA2 | KB2 | LG | KW | |
|-----------|-----|-----|-------|-------------|---------------------------------|----------|-----|-----------|----|-------------|--|
| 181 (217) | 130 | 4 | 145 | 4- $\phi 9$ | 103 | 107.5 | 74 | 160 (196) | 14 | 8 | |
| LR | S | LB | TP | LK | KH | LJ | | W | T | Weight (kg) | |
| 55±1 | 22 | 110 | M6x20 | 36 | 18 ⁰ _{-0.2} | 0.5±0.75 | | 8 | 7 | 9.5 (11) | |

2.5.6 MS1H3-29C15CD-A33*Z

| Technical Data of Motors in Flange Size 180 (mm) (Medium Inertia, Medium Capacity) | | |
|---|---------------------|------|
| Rated output (kW) | 2.9 | |
| Voltage (V) | 380 | |
| Rated torque (N·m) | 18.6 | |
| Maximum torque (N·m) | 46.5 | |
| Rated current (Arms) | 11.9 | |
| Maximum current (Arms) | 29.75 | |
| Rated speed (RPM) | 1500 | |
| Maximum speed (RPM) | 3000 | |
| Torque coefficient (N·m/Arms) | 1.82 | |
| Rotor moment of inertia (kg·cm ²) | Motor without brake | 55 |
| | Motor with brake | 57.2 |

■ Torque-Speed characteristics

- A — Continuous working area
- B — Short-term working area

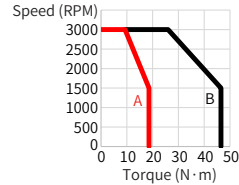

■ Heatsink-based derating curve

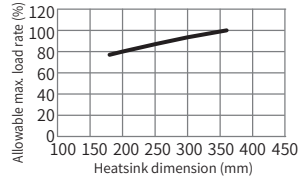

■ Electrical specifications of the motor with brake

| Holding Torque (N·m) | Supply Voltage (VDC) ±10% | Rated Power (W) | Coil Resistance (Ω) (±7%) | Exciting Current (A) | Apply Time (ms) | Release Time (ms) | Backlash (°) |
|----------------------|---------------------------|-----------------|---------------------------|----------------------|-----------------|-------------------|--------------|
| 50 | 24 | 40 | 14.4 | 1.67 | ≤ 200 | ≤ 100 | ≤ 0.5 |

■ Allowable load

| LF (mm) | Allowable Radial Load (N) | Allowable Axial Load (N) |
|---------|---------------------------|--------------------------|
| 79 | 1470 | 490 |

■ Dimension drawing

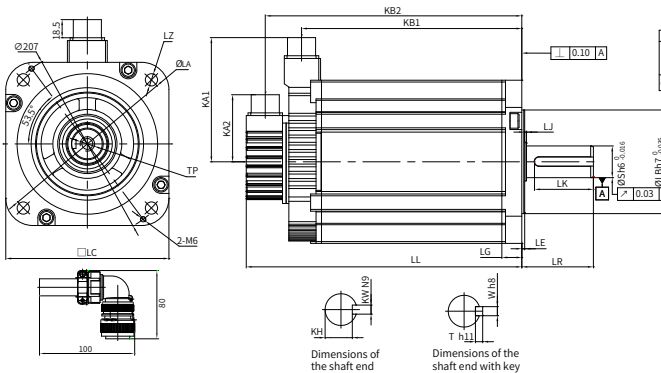

| | | | | | | | | | | |
|-----------|-----|---------|--------|---------|---------------------------------|----------|----|----|-------------|-----------|
| LL | LC | LE | LA | LZ | KA1 | KA2 | KW | LG | KB1 | KB2 |
| 197 (273) | 180 | 3.2±0.3 | 200 | 4-Φ13.5 | 138 | 74 | 10 | 18 | 136 (134) | 177 (253) |
| LR | S | LB | TP | LK | KH | LJ | W | T | Weight (kg) | |
| 79±1 | 35 | 114.3 | M12x25 | 65 | 30 ⁰ _{-0.2} | 0.3±0.75 | 10 | 8 | 15 (25) | |

2.5.7 MS1H3-44C15CD-A33*Z

| Technical Data of Motors in Flange Size 180 (mm) (Medium Inertia, Medium Capacity) | | |
|---|------------------------|------|
| Rated output (kW) | 4.4 | |
| Voltage (V) | 380 | |
| Rated torque (N·m) | 28.4 | |
| Maximum torque (N·m) | 71.1 | |
| Rated current (Arms) | 16.5 | |
| Maximum current (Arms) | 40.5 | |
| Rated speed (RPM) | 1500 | |
| Maximum speed (RPM) | 3000 | |
| Torque coefficient (N·m/Arms) | 1.9 | |
| Rotor moment of inertia (kg·cm ²) | Motor without brake | 88.9 |
| | Motor with brake | 90.8 |

■ Torque-Speed characteristics

- A — Continuous working area
- B — Short-term working area

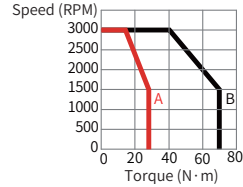

■ Heatsink-based derating curve

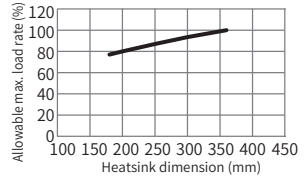

■ Electrical specifications of the motor with brake

| Holding Torque (N·m) | Supply Voltage (VDC) ±10% | Rated Power (W) | Coil Resistance (Ω) (±7%) | Exciting Current (A) | Apply Time (ms) | Release Time (ms) | Backlash (°) |
|----------------------|---------------------------|-----------------|---------------------------|----------------------|-----------------|-------------------|--------------|
| 50 | 24 | 40 | 14.4 | 1.67 | ≤ 200 | ≤ 100 | ≤ 0.5 |

■ Allowable load

| LF (mm) | Allowable Radial Load (N) | Allowable Axial Load (N) |
|---------|---------------------------|--------------------------|
| 79 | 1470 | 490 |

■ Dimension drawing

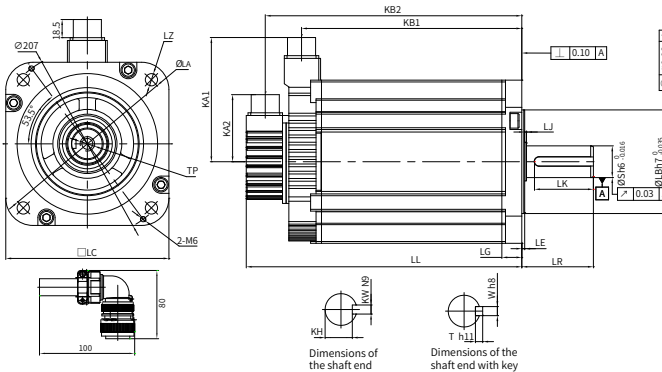

| | | | | | | | | | | |
|-----------|-----|---------|--------|---------|---------------------------------|----------|----|----|-------------|-----------|
| LL | LC | LE | LA | LZ | KA1 | KA2 | KW | LG | KB1 | KB2 |
| 230 (307) | 180 | 3.2±0.3 | 200 | 4-Φ13.5 | 138 | 74 | 10 | 18 | 169 (167) | 210 (286) |
| LR | S | LB | TP | LK | KH | LJ | W | T | Weight (kg) | |
| 79±1 | 35 | 114.3 | M12x25 | 65 | 30 ⁰ _{-0.2} | 0.3±0.75 | 10 | 8 | 19.5 (30) | |

2.5.8 MS1H3-55C15CD-A33*Z

| Technical Data of Motors in Flange Size 180 (mm) (Medium Inertia, Medium Capacity) | | |
|---|---------------------|-------|
| Rated output (kW) | 5.5 | |
| Voltage (V) | 380 | |
| Rated torque (N·m) | 35 | |
| Maximum torque (N·m) | 87.6 | |
| Rated current (Arms) | 20.85 | |
| Maximum current (Arms) | 52 | |
| Rated speed (RPM) | 1500 | |
| Maximum speed (RPM) | 3000 | |
| Torque coefficient (N·m/Arms) | 1.74 | |
| Rotor moment of inertia (kg·cm ²) | Motor without brake | 107 |
| | Motor with brake | 109.5 |

■ Torque-Speed characteristics

A — Continuous working area
B — Short-term working area

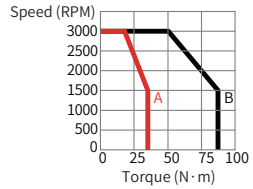

■ Heatsink-based derating curve

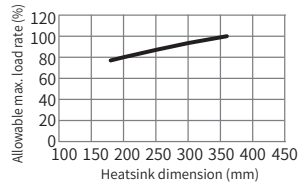

■ Electrical specifications of the motor with brake

| Holding Torque (N·m) | Supply Voltage (VDC) ±10% | Rated Power (W) | Coil Resistance (Ω) (±7%) | Exciting Current (A) | Apply Time (ms) | Release Time (ms) | Backlash (°) |
|----------------------|---------------------------|-----------------|---------------------------|----------------------|-----------------|-------------------|--------------|
| 50 | 24 | 40 | 14.4 | 1.67 | ≤ 200 | ≤ 100 | ≤ 0.5 |

■ Allowable load

| LF (mm) | Allowable Radial Load (N) | Allowable Axial Load (N) |
|---------|---------------------------|--------------------------|
| 113 | 1764 | 588 |

■ Dimension drawing

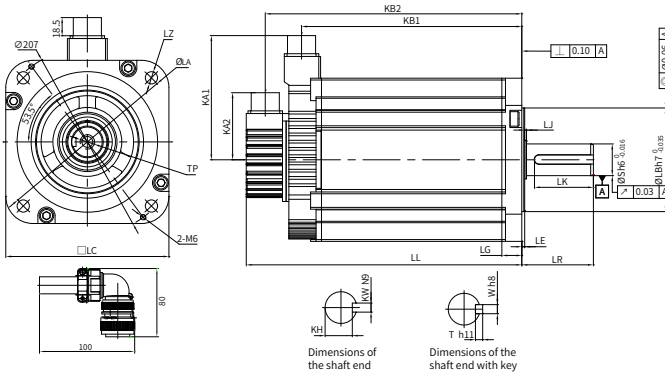

| LL | LC | LE | LA | LZ | KA1 | KA2 | KW | LG | KB1 | KB2 |
|-----------|-----|---------|--------|---------|---------------------------------|----------|----|----|-------------|-----------|
| 274 (350) | 180 | 3.2±0.3 | 200 | 4-Φ13.5 | 138 | 74 | 12 | 18 | 213 (211) | 254 (330) |
| LR | S | LB | TP | LK | KH | LJ | W | T | Weight (kg) | |
| 113±1 | 42 | 114.3 | M16x32 | 96 | 37 ⁰ _{-0.2} | 0.3±0.75 | 12 | 8 | 28 (38) | |

2.5.9 MS1H3-75C15CD-A33*Z

| Technical Data of Motors in Flange Size 180 (mm) (Medium Inertia, Medium Capacity) | | |
|---|---------------------|-------|
| Rated output (kW) | 7.5 | |
| Voltage (V) | 380 | |
| Rated torque (N·m) | 48 | |
| Maximum torque (N·m) | 119 | |
| Rated current (Arms) | 25.7 | |
| Maximum current (Arms) | 65 | |
| Rated speed (RPM) | 1500 | |
| Maximum speed (RPM) | 3000 | |
| Torque coefficient (N·m/Arms) | 1.99 | |
| Rotor moment of inertia (kg·cm ²) | Motor without brake | 141 |
| | Motor with brake | 143.1 |

■ Torque-Speed characteristics

- A — Continuous working area
- B — Short-term working area

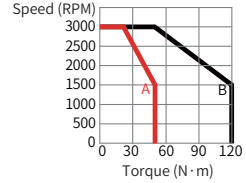

■ Heatsink-based derating curve

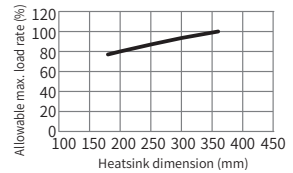

■ Electrical specifications of the motor with brake

| Holding Torque (N·m) | Supply Voltage (VDC) ±10% | Rated Power (W) | Coil Resistance (Ω) (±7%) | Exciting Current (A) | Apply Time (ms) | Release Time (ms) | Backlash (°) |
|----------------------|---------------------------|-----------------|---------------------------|----------------------|-----------------|-------------------|--------------|
| 50 | 24 | 40 | 14.4 | 1.67 | ≤ 200 | ≤ 100 | ≤ 0.5 |

■ Allowable load

| LF (mm) | Allowable Radial Load (N) | Allowable Axial Load (N) |
|---------|---------------------------|--------------------------|
| 113 | 1764 | 588 |

■ Dimension drawing

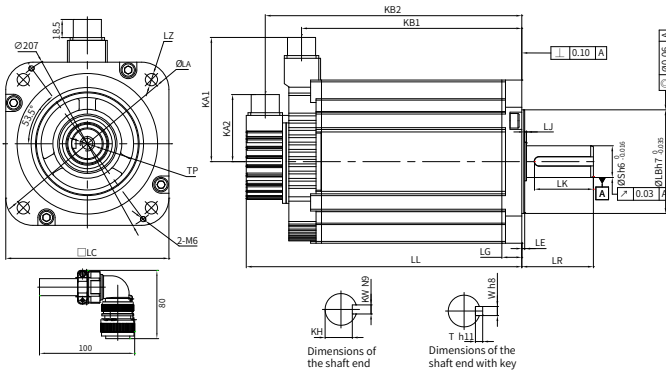

| | | | | | | | | | | |
|-----------|-----|---------|--------|---------|---------------------------------|----------|----|----|-------------|-----------|
| LL | LC | LE | LA | LZ | KA1 | KA2 | KW | LG | KB1 | KB2 |
| 330 (407) | 180 | 3.2±0.3 | 200 | 4-Φ13.5 | 138 | 74 | 12 | 18 | 269 (267) | 310 (386) |
| LR | S | LB | TP | LK | KH | LJ | W | T | Weight (kg) | |
| 113±1 | 42 | 114.3 | M16x32 | 96 | 37 ⁰ _{-0.2} | 0.3±0.75 | 12 | 8 | 32 (42) | |

3. Cables

3.1 Cable Models

3.1.1 Encoder Cable Model

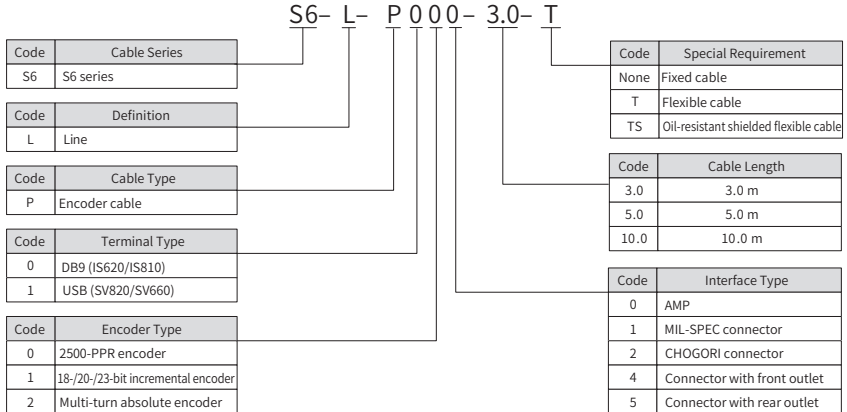

Figure 3-1 Description of encoder cable model

3.1.2 Power Cable Model

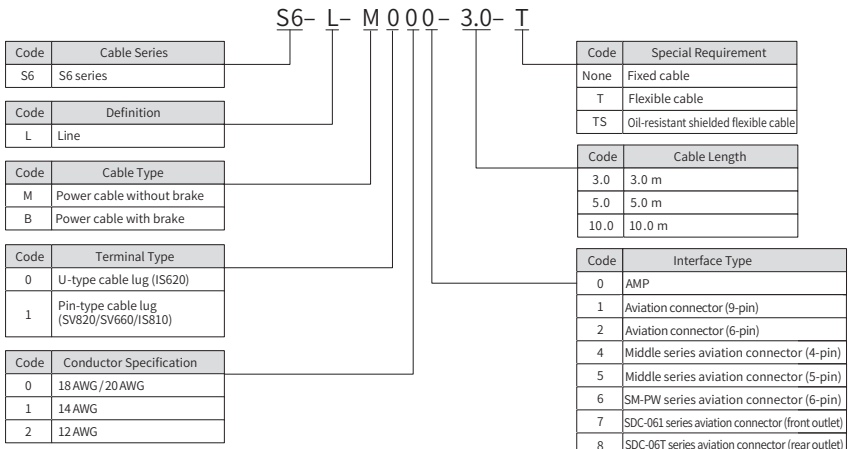

Figure 3-2 Description of power cable model



- ◆ Cable models ending with "-T" are flexible cables fit for cable carriers. For example, model number "S6-L-P120-***" represents fixed cables; model number "S6-L-P120-**-T" represents flexible cables.
- ◆ Cable models ending with "-TS" are oil-resistant shielded flexible cables. Inovance encoder cables are shielded cables.

3.2 Cables Types

1 Fixed cables

Do not bend or move fixed cables during use. Bending or moving fixed cables may break cables and lead to a series of cable-related faults such as poor contact. Secure fixed cables through fixed binding and reserve certain bending radius to avoid stress on cables.

2 Flexible cables

Flexible cables can move along with cable carriers without high risk of abrasion.



- ◆ Do not twine or twist cables inside the cable carrier.
- ◆ Ensure cables can move within the bending radius. Do not move cables by force. A relative movement between cables or between the cable and the guiding device must be available.
- ◆ Do not fix or bundle cables inside the cable carrier. Cables can be bundled and fixed only at the two unmovable ends of the cable carrier.

3 Oil-resistant shielded flexible cables

Oil-resistant shielded flexible cables apply to applications requiring shielded power cables, such as machine tools, cutting fluids, and cutting compounds.



- ◆ S6-C24 cable kit is required for terminal-type motor encoder cables longer than 25 m. Contact Inovance sales staff for details on the cable length.
- ◆ For lead wire-type motor encoder cables longer than 25 m, contact Inovance sales staff.

3.3 Selection of Motor Cables and Connectors

3.3.1 IS620 Series Servo Drives

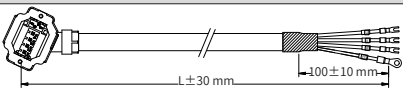
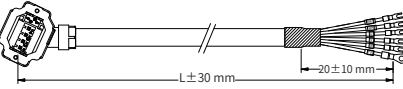
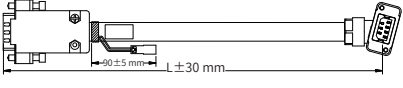
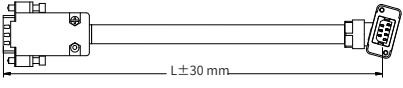
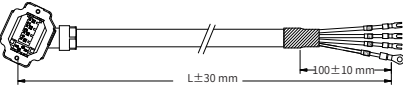
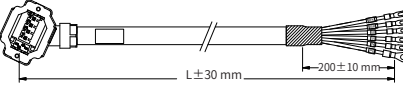
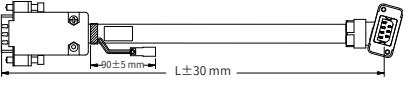
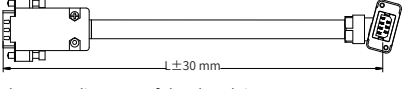
| Motor Model | Flange Size | Cable Name | Cable Model | Length (mm) | Outline Drawing of the Cable | | | | | | | | | |
|--------------------------------------|--------------------------------------|------------------------|---|---|---|---|---|---|-------------------------|-------------------------|-------------------------|--------|--------|--------|
| MS1H1 and MS1H4 terminal-type motors | 40 60 80 | Front outlet | Power cable (without brake) | S6-L-M007-3.0 | 3000 |  <p style="text-align: center;">Outer Diameter of the Sheath</p> <table border="1" style="width: 100%; text-align: center;"> <tr> <th>Fixed Cable</th> <th>Flexible Cable</th> <th>Shielded Flexible Cable</th> </tr> <tr> <td>6.5 mm</td> <td>6.5 mm</td> <td>6.5 mm</td> </tr> </table> | Fixed Cable | Flexible Cable | Shielded Flexible Cable | 6.5 mm | 6.5 mm | 6.5 mm | | |
| | | | | Fixed Cable | Flexible Cable | | Shielded Flexible Cable | | | | | | | |
| | | | | 6.5 mm | 6.5 mm | | 6.5 mm | | | | | | | |
| | | | S6-L-M007-5.0 | 5000 | | | | | | | | | | |
| | | | S6-L-M007-10.0 | 10000 | | | | | | | | | | |
| | | | Power cable (with brake) | S6-L-B007-3.0 | 3000 | |  <p style="text-align: center;">Outer Diameter of the Sheath</p> <table border="1" style="width: 100%; text-align: center;"> <tr> <th>Fixed Cable</th> <th>Flexible Cable</th> <th>Shielded Flexible Cable</th> </tr> <tr> <td>6.5 mm</td> <td>6.5 mm</td> <td>6.5 mm</td> </tr> </table> | Fixed Cable | Flexible Cable | Shielded Flexible Cable | 6.5 mm | 6.5 mm | 6.5 mm | |
| | | Fixed Cable | | Flexible Cable | Shielded Flexible Cable | | | | | | | | | |
| | | 6.5 mm | | 6.5 mm | 6.5 mm | | | | | | | | | |
| | | S6-L-B007-5.0 | 5000 | | | | | | | | | | | |
| | | S6-L-B007-10.0 | 10000 | | | | | | | | | | | |
| | | Absolute encoder cable | S6-L-P024-3.0 | 3000 |  <p>The outer diameter of the sheath is 6.0 mm.</p> | | | | | | | | | |
| | | | S6-L-P024-5.0 | 5000 | | | | | | | | | | |
| | S6-L-P024-10.0 | | 10000 | | | | | | | | | | | |
| | Incremental encoder cable | S6-L-P014-3.0 | 3000 |  <p>The outer diameter of the sheath is 6.0 mm.</p> | | | | | | | | | | |
| | | S6-L-P014-5.0 | 5000 | | | | | | | | | | | |
| | | S6-L-P014-10.0 | 10000 | | | | | | | | | | | |
| | MS1H1 and MS1H4 terminal-type motors | 40 60 80 | Rear outlet | | Power cable (without brake) | S6-L-M008-3.0 | 3000 |  <p style="text-align: center;">Outer Diameter of the Sheath</p> <table border="1" style="width: 100%; text-align: center;"> <tr> <th>Fixed Cable</th> <th>Flexible Cable</th> <th>Shielded Flexible Cable</th> </tr> <tr> <td>6.5 mm</td> <td>6.5 mm</td> <td>6.5 mm</td> </tr> </table> | Fixed Cable | Flexible Cable | Shielded Flexible Cable | 6.5 mm | 6.5 mm | 6.5 mm |
| | | | | | | Fixed Cable | Flexible Cable | | Shielded Flexible Cable | | | | | |
| 6.5 mm | | | | | | 6.5 mm | 6.5 mm | | | | | | | |
| S6-L-M008-5.0 | | | | 5000 | | | | | | | | | | |
| S6-L-M008-10.0 | | | | 10000 | | | | | | | | | | |
| Power cable (with brake) | | | | S6-L-B008-3.0 | 3000 |  <p style="text-align: center;">Outer Diameter of the Sheath</p> <table border="1" style="width: 100%; text-align: center;"> <tr> <th>Fixed Cable</th> <th>Flexible Cable</th> <th>Shielded Flexible Cable</th> </tr> <tr> <td>6.5 mm</td> <td>6.5 mm</td> <td>6.5 mm</td> </tr> </table> | Fixed Cable | | Flexible Cable | Shielded Flexible Cable | 6.5 mm | 6.5 mm | 6.5 mm | |
| | Fixed Cable | | Flexible Cable | Shielded Flexible Cable | | | | | | | | | | |
| | 6.5 mm | | 6.5 mm | 6.5 mm | | | | | | | | | | |
| S6-L-B008-5.0 | 5000 | | | | | | | | | | | | | |
| S6-L-B008-10.0 | 10000 | | | | | | | | | | | | | |
| Absolute encoder cable | S6-L-P025-3.0 | | 3000 |  <p>The outer diameter of the sheath is 6.0 mm.</p> | | | | | | | | | | |
| | S6-L-P025-5.0 | | 5000 | | | | | | | | | | | |
| | S6-L-P025-10.0 | 10000 | | | | | | | | | | | | |
| Incremental encoder cable | S6-L-P015-3.0 | 3000 |  <p>The outer diameter of the sheath is 6.0 mm.</p> | | | | | | | | | | | |
| | S6-L-P015-5.0 | 5000 | | | | | | | | | | | | |
| | S6-L-P015-10.0 | 10000 | | | | | | | | | | | | |

3. Cables

| Motor Model | Flange Size | Cable Name | Cable Model | Length (mm) | Outline Drawing of the Cable | | | | | | | | |
|---------------------------------------|------------------------------|------------------------------|-------------------------|---|--|--|------------------------------|--|-------------|----------------|-------------------------|-------------------------|---------|
| MS1H1 and MS1H4 lead wire-type motors | 40 60 80 | Power cable (without brake) | S6-L-M00-3.0 | 3000 | | | | | | | | | |
| | | | S6-L-M00-5.0 | 5000 | | | | | | | | | |
| | | | S6-L-M00-10.0 | 10000 | | <table border="1"> <tr> <th colspan="3">Outer Diameter of the Sheath</th> </tr> <tr> <th>Fixed Cable</th> <th>Flexible Cable</th> <th>Shielded Flexible Cable</th> </tr> <tr> <td>6.5 mm</td> <td>6.5 mm</td> <td>6.5 mm</td> </tr> </table> | Outer Diameter of the Sheath | | | Fixed Cable | Flexible Cable | Shielded Flexible Cable | 6.5 mm |
| | | Outer Diameter of the Sheath | | | | | | | | | | | |
| | | Fixed Cable | Flexible Cable | Shielded Flexible Cable | | | | | | | | | |
| | | 6.5 mm | 6.5 mm | 6.5 mm | | | | | | | | | |
| | Power cable (with brake) | S6-L-B00-3.0 | 3000 | | | | | | | | | | |
| | | S6-L-B00-5.0 | 5000 | | | | | | | | | | |
| | | S6-L-B00-10.0 | 10000 | | <table border="1"> <tr> <th colspan="3">Outer Diameter of the Sheath</th> </tr> <tr> <th>Fixed Cable</th> <th>Flexible Cable</th> <th>Shielded Flexible Cable</th> </tr> <tr> <td>6.5 mm</td> <td>6.5 mm</td> <td>6.5 mm</td> </tr> </table> | Outer Diameter of the Sheath | | | Fixed Cable | Flexible Cable | Shielded Flexible Cable | 6.5 mm | 6.5 mm |
| | Outer Diameter of the Sheath | | | | | | | | | | | | |
| | Fixed Cable | Flexible Cable | Shielded Flexible Cable | | | | | | | | | | |
| | 6.5 mm | 6.5 mm | 6.5 mm | | | | | | | | | | |
| Absolute encoder cable | S6-L-P20-3.0 | 3000 | | | | | | | | | | | |
| | S6-L-P20-5.0 | 5000 | | | | | | | | | | | |
| | S6-L-P20-10.0 | 10000 | | The outer diameter of the sheath is 6.0 mm. | | | | | | | | | |
| Incremental encoder cable | S6-L-P00-3.0 | 3000 | | | | | | | | | | | |
| | S6-L-P00-5.0 | 5000 | | | | | | | | | | | |
| | S6-L-P00-10.0 | 10000 | | The outer diameter of the sheath is 6.0 mm. | | | | | | | | | |
| MS1H2 and MS1H3 connector-type motors | 100 130 | Power cable (without brake) | S6-L-M11-3.0 | 3000 | | | | | | | | | |
| | | | S6-L-M11-5.0 | 5000 | | | | | | | | | |
| | | | S6-L-M11-10.0 | 10000 | | <table border="1"> <tr> <th colspan="3">Outer Diameter of the Sheath</th> </tr> <tr> <th>Fixed Cable</th> <th>Flexible Cable</th> <th>Shielded Flexible Cable</th> </tr> <tr> <td>9.5 mm</td> <td>10.2 mm</td> <td>10.6 mm</td> </tr> </table> | Outer Diameter of the Sheath | | | Fixed Cable | Flexible Cable | Shielded Flexible Cable | 9.5 mm |
| | | Outer Diameter of the Sheath | | | | | | | | | | | |
| | | Fixed Cable | Flexible Cable | Shielded Flexible Cable | | | | | | | | | |
| | | 9.5 mm | 10.2 mm | 10.6 mm | | | | | | | | | |
| | Power cable (with brake) | S6-L-B11-3.0 | 3000 | | | | | | | | | | |
| | | S6-L-B11-5.0 | 5000 | | | | | | | | | | |
| | | S6-L-B11-10.0 | 10000 | | <table border="1"> <tr> <th colspan="3">Outer Diameter of the Sheath</th> </tr> <tr> <th>Fixed Cable</th> <th>Flexible Cable</th> <th>Shielded Flexible Cable</th> </tr> <tr> <td>9.5 mm</td> <td>10.2 mm</td> <td>10.6 mm</td> </tr> </table> | Outer Diameter of the Sheath | | | Fixed Cable | Flexible Cable | Shielded Flexible Cable | 9.5 mm | 10.2 mm |
| | Outer Diameter of the Sheath | | | | | | | | | | | | |
| | Fixed Cable | Flexible Cable | Shielded Flexible Cable | | | | | | | | | | |
| | 9.5 mm | 10.2 mm | 10.6 mm | | | | | | | | | | |
| Absolute encoder cable | S6-L-P21-3.0 | 3000 | | | | | | | | | | | |
| | S6-L-P21-5.0 | 5000 | | | | | | | | | | | |
| | S6-L-P21-10.0 | 10000 | | The outer diameter of the sheath is 6.0 mm. | | | | | | | | | |
| Incremental encoder cable | S6-L-P01-3.0 | 3000 | | | | | | | | | | | |
| | S6-L-P01-5.0 | 5000 | | | | | | | | | | | |
| | S6-L-P01-10.0 | 10000 | | The outer diameter of the sheath is 6.0 mm. | | | | | | | | | |

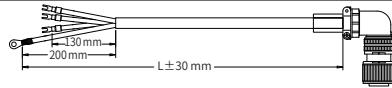
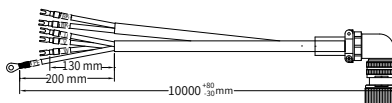
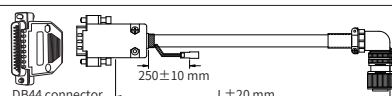
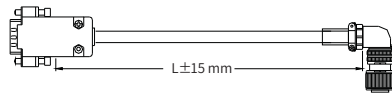
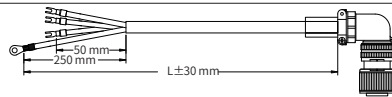
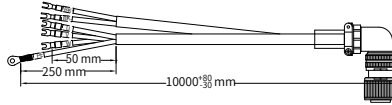
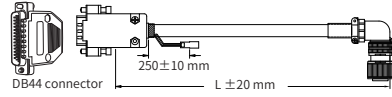
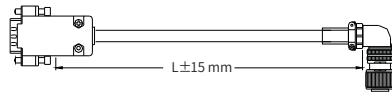
| Motor Model | Flange Size | Cable Name | Cable Model | Length (mm) | Outline Drawing of the Cable | | | | | | | | |
|--|---------------|------------------------------|--|---|--|---|------------------------------|--|--|-------------|----------------|-------------------------|---------|
| MS1H3 connector-type motors (2.9 kW) | 180 | Power cable (without brake) | S6-L-M12-3.0 | 3000 |  | | | | | | | | |
| | | | S6-L-M12-5.0 | 5000 | | | | | | | | | |
| | | | S6-L-M12-10.0 | 10000 | | <table border="1"> <thead> <tr> <th colspan="3">Outer Diameter of the Sheath</th> </tr> <tr> <th>Fixed Cable</th> <th>Flexible Cable</th> <th>Shielded Flexible Cable</th> </tr> </thead> <tbody> <tr> <td>9.5 mm</td> <td>10.2 mm</td> <td>10.6 mm</td> </tr> </tbody> </table> | Outer Diameter of the Sheath | | | Fixed Cable | Flexible Cable | Shielded Flexible Cable | 9.5 mm |
| | | Outer Diameter of the Sheath | | | | | | | | | | | |
| | | Fixed Cable | Flexible Cable | Shielded Flexible Cable | | | | | | | | | |
| | | 9.5 mm | 10.2 mm | 10.6 mm | | | | | | | | | |
| | | Power cable (with brake) | S6-L-B12-3.0 | 3000 |  | | | | | | | | |
| | | | S6-L-B12-5.0 | 5000 | | | | | | | | | |
| | | | S6-L-B12-10.0 | 10000 | | <table border="1"> <thead> <tr> <th colspan="3">Outer Diameter of the Sheath</th> </tr> <tr> <th>Fixed Cable</th> <th>Flexible Cable</th> <th>Shielded Flexible Cable</th> </tr> </thead> <tbody> <tr> <td>9.5 mm</td> <td>10.2 mm</td> <td>10.6 mm</td> </tr> </tbody> </table> | Outer Diameter of the Sheath | | | Fixed Cable | Flexible Cable | Shielded Flexible Cable | 9.5 mm |
| | | Outer Diameter of the Sheath | | | | | | | | | | | |
| | | Fixed Cable | Flexible Cable | Shielded Flexible Cable | | | | | | | | | |
| | | 9.5 mm | 10.2 mm | 10.6 mm | | | | | | | | | |
| Absolute encoder cable | S6-L-P21-3.0 | 3000 |  | | | | | | | | | | |
| | S6-L-P21-5.0 | 5000 | | | | | | | | | | | |
| | S6-L-P21-10.0 | 10000 | | The outer diameter of the sheath is 6.0 mm. | | | | | | | | | |
| Incremental encoder cable | S6-L-P01-3.0 | 3000 |  | | | | | | | | | | |
| | S6-L-P01-5.0 | 5000 | | | | | | | | | | | |
| | S6-L-P01-10.0 | 10000 | | The outer diameter of the sheath is 6.0 mm. | | | | | | | | | |
| MS1H3 connector-type motors (4.4 kW and above) | 180 | Power cable (without brake) | S6-L-M22-3.0 | 3000 |  | | | | | | | | |
| | | | S6-L-M22-5.0 | 5000 | | | | | | | | | |
| | | | S6-L-M22-10.0 | 10000 | | <table border="1"> <thead> <tr> <th colspan="3">Outer Diameter of the Sheath</th> </tr> <tr> <th>Fixed Cable</th> <th>Flexible Cable</th> <th>Shielded Flexible Cable</th> </tr> </thead> <tbody> <tr> <td>12.2 mm</td> <td>12.5 mm</td> <td>13.2 mm</td> </tr> </tbody> </table> | Outer Diameter of the Sheath | | | Fixed Cable | Flexible Cable | Shielded Flexible Cable | 12.2 mm |
| | | Outer Diameter of the Sheath | | | | | | | | | | | |
| | | Fixed Cable | Flexible Cable | Shielded Flexible Cable | | | | | | | | | |
| | | 12.2 mm | 12.5 mm | 13.2 mm | | | | | | | | | |
| | | Power cable (with brake) | S6-L-B22-3.0 | 3000 |  | | | | | | | | |
| | | | S6-L-B22-5.0 | 5000 | | | | | | | | | |
| | | | S6-L-B22-10.0 | 10000 | | <table border="1"> <thead> <tr> <th colspan="3">Outer Diameter of the Sheath</th> </tr> <tr> <th>Fixed Cable</th> <th>Flexible Cable</th> <th>Shielded Flexible Cable</th> </tr> </thead> <tbody> <tr> <td>12.2 mm</td> <td>12.5 mm</td> <td>13.2 mm</td> </tr> </tbody> </table> | Outer Diameter of the Sheath | | | Fixed Cable | Flexible Cable | Shielded Flexible Cable | 12.2 mm |
| | | Outer Diameter of the Sheath | | | | | | | | | | | |
| | | Fixed Cable | Flexible Cable | Shielded Flexible Cable | | | | | | | | | |
| | | 12.2 mm | 12.5 mm | 13.2 mm | | | | | | | | | |
| Absolute encoder cable | S6-L-P21-3.0 | 3000 |  | | | | | | | | | | |
| | S6-L-P21-5.0 | 5000 | | | | | | | | | | | |
| | S6-L-P21-10.0 | 10000 | | The outer diameter of the sheath is 6.0 mm. | | | | | | | | | |
| Incremental encoder cable | S6-L-P01-3.0 | 3000 |  | | | | | | | | | | |
| | S6-L-P01-5.0 | 5000 | | | | | | | | | | | |
| | S6-L-P01-10.0 | 10000 | | The outer diameter of the sheath is 6.0 mm. | | | | | | | | | |

3. Cables

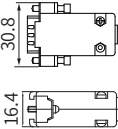
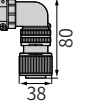
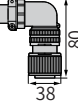



| Applicable Motor Model | Connector Kit | Outline Drawing and Dimensions | | | |
|--|---------------|--|---|---|---|
| MS1H2 | S6-C2 | | | | |
| MS1H3/MS1V3 (1.8 kW and below) | S6-C2 |  DB44 connector |  DB9 connector |  3108E20-29S aviation connector |  3108E20-18S aviation connector |
| MS1H3 (2.9 kW and above) | S6-C3 | | | | |
| MS1H1/MS1H4 lead wire-type (Z-S) motors | S6-C1 | | | | |

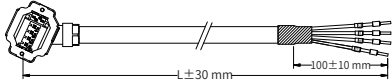
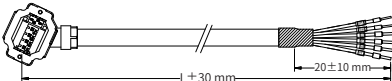
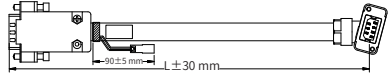

NOTE

◆ Connector kits are needed only when customized cables are used.

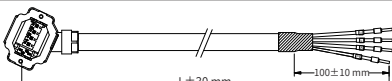
3.3.2 IS810N-INT Series Servo Drives

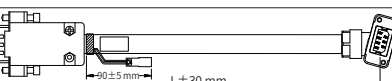
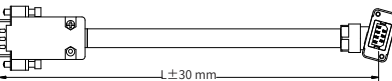
| Motor Model | Flange Size | Cable Name | Cable Model | Length (mm) | Outline Drawing of the Cable | | | | | | | | | | |
|--------------------------------------|----------------|------------------------|---|------------------------------|---|---|------------------------------|--|--|-------------|----------------|-------------------------|--------|--------|--------|
| MS1H1 and MS1H4 terminal-type motors | 40 60 80 | Front outlet | Power cable (without brake) | S6-L-M107-3.0 | 3000 |  <p>$L \pm 30$ mm 100 ± 10 mm</p> <table border="1"> <thead> <tr> <th colspan="3">Outer Diameter of the Sheath</th> </tr> <tr> <th>Fixed Cable</th> <th>Flexible Cable</th> <th>Shielded Flexible Cable</th> </tr> </thead> <tbody> <tr> <td>6.5 mm</td> <td>6.5 mm</td> <td>6.5 mm</td> </tr> </tbody> </table> | Outer Diameter of the Sheath | | | Fixed Cable | Flexible Cable | Shielded Flexible Cable | 6.5 mm | 6.5 mm | 6.5 mm |
| | | | | Outer Diameter of the Sheath | | | | | | | | | | | |
| | | | | Fixed Cable | Flexible Cable | | Shielded Flexible Cable | | | | | | | | |
| | | | 6.5 mm | 6.5 mm | 6.5 mm | | | | | | | | | | |
| | | | S6-L-M107-5.0 | 5000 | | | | | | | | | | | |
| | | | S6-L-M107-10.0 | 10000 | | | | | | | | | | | |
| | | | Power cable (with brake) | S6-L-B107-3.0 | 3000 |  <p>$L \pm 30$ mm 20 ± 10 mm</p> <table border="1"> <thead> <tr> <th colspan="3">Outer Diameter of the Sheath</th> </tr> <tr> <th>Fixed Cable</th> <th>Flexible Cable</th> <th>Shielded Flexible Cable</th> </tr> </thead> <tbody> <tr> <td>6.5 mm</td> <td>6.5 mm</td> <td>6.5 mm</td> </tr> </tbody> </table> | Outer Diameter of the Sheath | | | Fixed Cable | Flexible Cable | Shielded Flexible Cable | 6.5 mm | 6.5 mm | 6.5 mm |
| | | | | Outer Diameter of the Sheath | | | | | | | | | | | |
| | | | | Fixed Cable | Flexible Cable | | Shielded Flexible Cable | | | | | | | | |
| | | 6.5 mm | 6.5 mm | 6.5 mm | | | | | | | | | | | |
| | | S6-L-B107-5.0 | 5000 | | | | | | | | | | | | |
| | | S6-L-B107-10.0 | 10000 | | | | | | | | | | | | |
| | | Absolute encoder cable | S6-L-P024-3.0 | 3000 |  <p>30 ± 5 mm $L \pm 30$ mm</p> <p>The outer diameter of the sheath is 6.0 mm.</p> | | | | | | | | | | |
| | | | S6-L-P024-5.0 | 5000 | | | | | | | | | | | |
| | | | S6-L-P024-10.0 | 10000 | | | | | | | | | | | |
| Incremental encoder cable | S6-L-P014-3.0 | 3000 |  <p>$L \pm 30$ mm</p> <p>The outer diameter of the sheath is 6.0 mm.</p> | | | | | | | | | | | | |
| | S6-L-P014-5.0 | 5000 | | | | | | | | | | | | | |
| | S6-L-P014-10.0 | 10000 | | | | | | | | | | | | | |
| MS1H1 and MS1H4 terminal-type motors | 40 60 80 | Rear outlet | Power cable (without brake) | S6-L-M108-3.0 | 3000 |  <p>$L \pm 30$ mm 100 ± 10 mm</p> <table border="1"> <thead> <tr> <th colspan="3">Outer Diameter of the Sheath</th> </tr> <tr> <th>Fixed Cable</th> <th>Flexible Cable</th> <th>Shielded Flexible Cable</th> </tr> </thead> <tbody> <tr> <td>6.5 mm</td> <td>6.5 mm</td> <td>6.5 mm</td> </tr> </tbody> </table> | Outer Diameter of the Sheath | | | Fixed Cable | Flexible Cable | Shielded Flexible Cable | 6.5 mm | 6.5 mm | 6.5 mm |
| | | | | Outer Diameter of the Sheath | | | | | | | | | | | |
| | | | | Fixed Cable | Flexible Cable | | Shielded Flexible Cable | | | | | | | | |
| | | | 6.5 mm | 6.5 mm | 6.5 mm | | | | | | | | | | |
| | | | S6-L-M108-5.0 | 5000 | | | | | | | | | | | |
| | | | S6-L-M108-10.0 | 10000 | | | | | | | | | | | |
| | | | Power cable (with brake) | S6-L-B108-3.0 | 3000 |  <p>$L \pm 30$ mm 200 ± 10 mm</p> <table border="1"> <thead> <tr> <th colspan="3">Outer Diameter of the Sheath</th> </tr> <tr> <th>Fixed Cable</th> <th>Flexible Cable</th> <th>Shielded Flexible Cable</th> </tr> </thead> <tbody> <tr> <td>6.5 mm</td> <td>6.5 mm</td> <td>6.5 mm</td> </tr> </tbody> </table> | Outer Diameter of the Sheath | | | Fixed Cable | Flexible Cable | Shielded Flexible Cable | 6.5 mm | 6.5 mm | 6.5 mm |
| | | | | Outer Diameter of the Sheath | | | | | | | | | | | |
| | | | | Fixed Cable | Flexible Cable | | Shielded Flexible Cable | | | | | | | | |
| | | 6.5 mm | 6.5 mm | 6.5 mm | | | | | | | | | | | |
| | | S6-L-B108-5.0 | 5000 | | | | | | | | | | | | |
| | | S6-L-B108-10.0 | 10000 | | | | | | | | | | | | |
| | | Absolute encoder cable | S6-L-P025-3.0 | 3000 |  <p>30 ± 5 mm $L \pm 30$ mm</p> <p>The outer diameter of the sheath is 6.0 mm.</p> | | | | | | | | | | |
| | | | S6-L-P025-5.0 | 5000 | | | | | | | | | | | |
| | | | S6-L-P025-10.0 | 10000 | | | | | | | | | | | |
| Incremental encoder cable | S6-L-P015-3.0 | 3000 |  <p>$L \pm 30$ mm</p> <p>The outer diameter of the sheath is 6.0 mm.</p> | | | | | | | | | | | | |
| | S6-L-P015-5.0 | 5000 | | | | | | | | | | | | | |
| | S6-L-P015-10.0 | 10000 | | | | | | | | | | | | | |

3. Cables

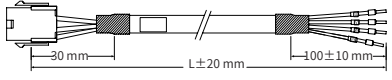
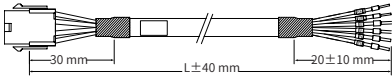
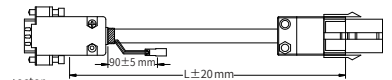
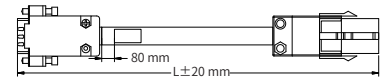
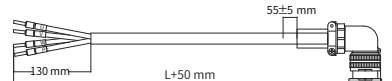
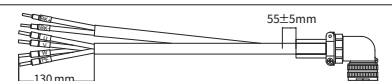
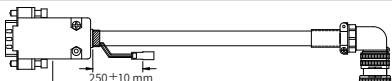
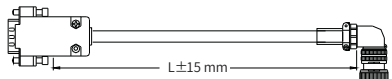
| Motor Model | Flange Size | Cable Name | Cable Model | Length (mm) | Outline Drawing of the Cable | | | | | | |
|---------------------------------------|----------------|-----------------------------------|---|----------------|---|-------------------------|----------------|-------------------------|--------|---------|---------|
| MS1H1 and MS1H4 lead wire-type motors | 40 60 80 | Power cable (without brake) | S6-L-M100-3.0 | 3000 |  <p>Outer Diameter of the Sheath</p> <table border="1"> <tr> <th>Fixed Cable</th> <th>Flexible Cable</th> <th>Shielded Flexible Cable</th> </tr> <tr> <td>6.5 mm</td> <td>6.5 mm</td> <td>6.5 mm</td> </tr> </table> | Fixed Cable | Flexible Cable | Shielded Flexible Cable | 6.5 mm | 6.5 mm | 6.5 mm |
| | | | Fixed Cable | Flexible Cable | | Shielded Flexible Cable | | | | | |
| | | | 6.5 mm | 6.5 mm | | 6.5 mm | | | | | |
| | | S6-L-M100-5.0 | 5000 | | | | | | | | |
| | | S6-L-M100-10.0 | 10000 | | | | | | | | |
| | | Power cable (with brake) | S6-L-B100-3.0 | 3000 |  <p>Outer Diameter of the Sheath</p> <table border="1"> <tr> <th>Fixed Cable</th> <th>Flexible Cable</th> <th>Shielded Flexible Cable</th> </tr> <tr> <td>6.5 mm</td> <td>6.5 mm</td> <td>6.5 mm</td> </tr> </table> | Fixed Cable | Flexible Cable | Shielded Flexible Cable | 6.5 mm | 6.5 mm | 6.5 mm |
| | | | Fixed Cable | Flexible Cable | | Shielded Flexible Cable | | | | | |
| | | | 6.5 mm | 6.5 mm | | 6.5 mm | | | | | |
| | | S6-L-B100-5.0 | 5000 | | | | | | | | |
| | | S6-L-B100-10.0 | 10000 | | | | | | | | |
| | | Absolute encoder cable | S6-L-P020-3.0 | 3000 |  <p>The outer diameter of the sheath is 6.0 mm.</p> | | | | | | |
| | | | S6-L-P020-5.0 | 5000 | | | | | | | |
| S6-L-P020-10.0 | 10000 | | | | | | | | | | |
| Incremental encoder cable | S6-L-P010-3.0 | 3000 |  <p>The outer diameter of the sheath is 6.0 mm.</p> | | | | | | | | |
| | S6-L-P010-5.0 | 5000 | | | | | | | | | |
| | S6-L-P010-10.0 | 10000 | | | | | | | | | |
| MS1H2 and MS1H3 connector-type motors | 100 130 | Power cable (motor without brake) | S6-L-M111-3.0 | 3000 |  <p>Outer Diameter of the Sheath</p> <table border="1"> <tr> <th>Fixed Cable</th> <th>Flexible Cable</th> <th>Shielded Flexible Cable</th> </tr> <tr> <td>9.5 mm</td> <td>10.2 mm</td> <td>10.6 mm</td> </tr> </table> | Fixed Cable | Flexible Cable | Shielded Flexible Cable | 9.5 mm | 10.2 mm | 10.6 mm |
| | | | Fixed Cable | Flexible Cable | | Shielded Flexible Cable | | | | | |
| | | | 9.5 mm | 10.2 mm | | 10.6 mm | | | | | |
| | | S6-L-M111-5.0 | 5000 | | | | | | | | |
| | | S6-L-M111-10.0 | 10000 | | | | | | | | |
| | | Power cable (motor with brake) | S6-L-B111-3.0 | 3000 |  <p>Outer Diameter of the Sheath</p> <table border="1"> <tr> <th>Fixed Cable</th> <th>Flexible Cable</th> <th>Shielded Flexible Cable</th> </tr> <tr> <td>9.5 mm</td> <td>10.2 mm</td> <td>10.6 mm</td> </tr> </table> | Fixed Cable | Flexible Cable | Shielded Flexible Cable | 9.5 mm | 10.2 mm | 10.6 mm |
| | | | Fixed Cable | Flexible Cable | | Shielded Flexible Cable | | | | | |
| | | | 9.5 mm | 10.2 mm | | 10.6 mm | | | | | |
| | | S6-L-B111-5.0 | 5000 | | | | | | | | |
| | | S6-L-B111-10.0 | 10000 | | | | | | | | |
| | | Absolute encoder cable | S6-L-P021-3.0 | 3000 |  <p>The outer diameter of the sheath is 6.0 mm.</p> | | | | | | |
| | | | S6-L-P021-5.0 | 5000 | | | | | | | |
| S6-L-P021-10.0 | 10000 | | | | | | | | | | |
| Incremental encoder cable | S6-L-P011-3.0 | 3000 |  <p>The outer diameter of the sheath is 6.0 mm.</p> | | | | | | | | |
| | S6-L-P011-5.0 | 5000 | | | | | | | | | |
| | S6-L-P011-10.0 | 10000 | | | | | | | | | |

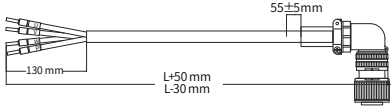
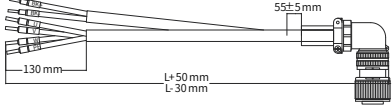
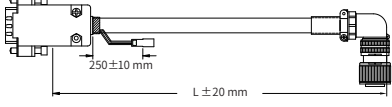
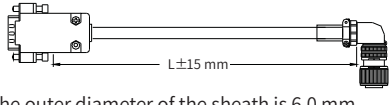
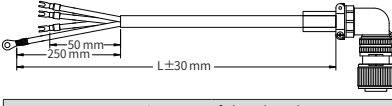
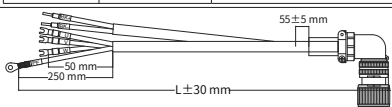
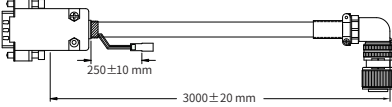
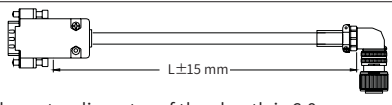
| Motor Model | Flange Size | Cable Name | Cable Model | Length (mm) | Outline Drawing of the Cable | | | | | | |
|--|------------------------|-----------------------------|---|---|---|-------------------------|----------------|-------------------------|---------|---------|---------|
| MS1H3 connector-type motors (2.9 kW) | 180 | Power cable (without brake) | S6-L-M112-3.0 | 3000 |  <p>Outer Diameter of the Sheath</p> <table border="1"> <thead> <tr> <th>Fixed Cable</th> <th>Flexible Cable</th> <th>Shielded Flexible Cable</th> </tr> </thead> <tbody> <tr> <td>9.5 mm</td> <td>10.2 mm</td> <td>10.6 mm</td> </tr> </tbody> </table> | Fixed Cable | Flexible Cable | Shielded Flexible Cable | 9.5 mm | 10.2 mm | 10.6 mm |
| | | | Fixed Cable | Flexible Cable | | Shielded Flexible Cable | | | | | |
| | | | 9.5 mm | 10.2 mm | | 10.6 mm | | | | | |
| | | S6-L-M112-5.0 | 5000 | | | | | | | | |
| | | S6-L-M112-10.0 | 10000 | | | | | | | | |
| | | Power cable (with brake) | S6-L-B112-3.0 | 3000 |  <p>Outer Diameter of the Sheath</p> <table border="1"> <thead> <tr> <th>Fixed Cable</th> <th>Flexible Cable</th> <th>Shielded Flexible Cable</th> </tr> </thead> <tbody> <tr> <td>9.5 mm</td> <td>10.2 mm</td> <td>10.6 mm</td> </tr> </tbody> </table> | Fixed Cable | Flexible Cable | Shielded Flexible Cable | 9.5 mm | 10.2 mm | 10.6 mm |
| | Fixed Cable | | Flexible Cable | Shielded Flexible Cable | | | | | | | |
| | 9.5 mm | | 10.2 mm | 10.6 mm | | | | | | | |
| | S6-L-B112-5.0 | 5000 | | | | | | | | | |
| | S6-L-B112-10.0 | 10000 | | | | | | | | | |
| | Absolute encoder cable | S6-L-P021-3.0 | 3000 |  <p>The outer diameter of the sheath is 6.0 mm.</p> | | | | | | | |
| | | S6-L-P021-5.0 | 5000 | | | | | | | | |
| Incremental encoder cable | S6-L-P011-3.0 | 3000 |  <p>The outer diameter of the sheath is 6.0 mm.</p> | | | | | | | | |
| | S6-L-P011-5.0 | 5000 | | | | | | | | | |
| | | S6-L-P011-10.0 | 10000 | | | | | | | | |
| MS1H3 connector-type motors (4.4 kW and above) | 180 | Power cable (without brake) | S6-L-M022-3.0 | 3000 |  <p>Outer Diameter of the Sheath</p> <table border="1"> <thead> <tr> <th>Fixed Cable</th> <th>Flexible Cable</th> <th>Shielded Flexible Cable</th> </tr> </thead> <tbody> <tr> <td>12.2 mm</td> <td>12.5 mm</td> <td>13.2 mm</td> </tr> </tbody> </table> | Fixed Cable | Flexible Cable | Shielded Flexible Cable | 12.2 mm | 12.5 mm | 13.2 mm |
| | | | Fixed Cable | Flexible Cable | | Shielded Flexible Cable | | | | | |
| | | | 12.2 mm | 12.5 mm | | 13.2 mm | | | | | |
| | | S6-L-M022-5.0 | 5000 | | | | | | | | |
| | | S6-L-M022-10.0 | 10000 | | | | | | | | |
| | | Power cable (with brake) | S6-L-B022-3.0 | 3000 |  <p>Outer Diameter of the Sheath</p> <table border="1"> <thead> <tr> <th>Fixed Cable</th> <th>Flexible Cable</th> <th>Shielded Flexible Cable</th> </tr> </thead> <tbody> <tr> <td>12.2 mm</td> <td>12.5 mm</td> <td>13.2 mm</td> </tr> </tbody> </table> | Fixed Cable | Flexible Cable | Shielded Flexible Cable | 12.2 mm | 12.5 mm | 13.2 mm |
| | Fixed Cable | | Flexible Cable | Shielded Flexible Cable | | | | | | | |
| | 12.2 mm | | 12.5 mm | 13.2 mm | | | | | | | |
| | S6-L-B022-5.0 | 5000 | | | | | | | | | |
| | S6-L-B022-10.0 | 10000 | | | | | | | | | |
| | Absolute encoder cable | S6-L-P021-3.0 | 3000 |  <p>The outer diameter of the sheath is 6.0 mm.</p> | | | | | | | |
| | | S6-L-P021-5.0 | 5000 | | | | | | | | |
| | | S6-L-P021-10.0 | 10000 | | | | | | | | |
| Incremental encoder cable | S6-L-P011-3.0 | 3000 |  <p>The outer diameter of the sheath is 6.0 mm.</p> | | | | | | | | |
| | S6-L-P011-5.0 | 5000 | | | | | | | | | |
| | S6-L-P011-10.0 | 10000 | | | | | | | | | |

3. Cables

| Applicable Motor Model | Connector Kit | Outline Drawing and Dimensions |
|--|--------------------------|--------------------------------|
| <p>MS1H1-*****-A3*** MS1H4-*****-A3*** (100 W to 1 kW)</p> | <p>S6-C23 S6-C24</p> | |
| <p>MS1H2-*****-A3*** (1.0 kW to 2.5 kW)</p> | <p>S6-C2</p> | |
| <p>MS1H2-*****-A3*** (3.0 kW to 5.0 kW)</p> | <p>S6-C2</p> | |
| <p>MS1H3-*****-A3*** (850 W to 1.8 kW)</p> | <p>S6-C2</p> | |
| <p>MS1H3-*****-A3*** (2.9 kW to 7.5 kW)</p> | <p>S6-C3</p> | |



◆ Connector kits are needed only when customized cables are used.

3.3.3 IS810P Series Servo Drives



| Motor Model | Flange Size | Cable Name | Cable Model | Length (mm) | Outline Drawing of the Cable | | | |
|--------------------------------------|----------------|--------------|---|---------------------|------------------------------|------------------------------|----------------|-------------------------|
| MS1H1 and MS1H4 terminal-type motors | 40 60 80 | Front outlet | Power cable (without brake) | S6-L-M007-3.0-810P | 3000 | | | |
| | | | | S6-L-M007-5.0-810P | 5000 | | | |
| | | | | S6-L-M007-10.0-810P | 10000 | | | |
| | | | | | | Outer Diameter of the Sheath | | |
| | | | | | | Fixed Cable | Flexible Cable | Shielded Flexible Cable |
| | | | | | | 6.5 mm | 6.5 mm | 6.5 mm |
| | | | Power cable (with brake) | S6-L-B007-3.0-810P | 3000 | | | |
| | | | | S6-L-B007-5.0-810P | 5000 | | | |
| | | | | S6-L-B007-10.0-810P | 10000 | | | |
| | | | | | | Outer Diameter of the Sheath | | |
| | | | | | | Fixed Cable | Flexible Cable | Shielded Flexible Cable |
| | | | | | | 6.5 mm | 6.5 mm | 6.5 mm |
| Absolute encoder cable | S6-L-P024-3.0 | 3000 | | | | | | |
| | S6-L-P024-5.0 | 5000 | | | | | | |
| | S6-L-P024-10.0 | 10000 | | | | | | |
| | | | The outer diameter of the sheath is 6.0 mm. | | | | | |
| Incremental encoder cable | S6-L-P014-3.0 | 3000 | | | | | | |
| | S6-L-P014-5.0 | 5000 | | | | | | |
| | S6-L-P014-10.0 | 10000 | | | | | | |
| | | | The outer diameter of the sheath is 6.0 mm. | | | | | |
| MS1H1 and MS1H4 terminal-type motors | 40 60 80 | Rear outlet | Power cable (without brake) | S6-L-M008-3.0-810P | 3000 | | | |
| | | | | S6-L-M008-5.0-810P | 5000 | | | |
| | | | | S6-L-M008-10.0-810P | 10000 | | | |
| | | | | | | Outer Diameter of the Sheath | | |
| | | | | | | Fixed Cable | Flexible Cable | Shielded Flexible Cable |
| | | | | | | 6.5 mm | 6.5 mm | 6.5 mm |
| | | | Power cable (with brake) | S6-L-B008-3.0-810P | 3000 | | | |
| | | | | S6-L-B008-5.0-810P | 5000 | | | |
| | | | | S6-L-B008-10.0-810P | 10000 | | | |
| | | | | | | Outer Diameter of the Sheath | | |
| | | | | | | Fixed Cable | Flexible Cable | Shielded Flexible Cable |
| | | | | | | 6.5 mm | 6.5 mm | 6.5 mm |
| Absolute encoder cable | S6-L-P025-3.0 | 3000 | | | | | | |
| | S6-L-P025-5.0 | 5000 | | | | | | |
| | S6-L-P025-10.0 | 10000 | | | | | | |
| | | | The outer diameter of the sheath is 6.0 mm. | | | | | |
| Incremental encoder cable | S6-L-P015-3.0 | 3000 | | | | | | |
| | S6-L-P015-5.0 | 5000 | | | | | | |
| | S6-L-P015-10.0 | 10000 | | | | | | |
| | | | The outer diameter of the sheath is 6.0 mm. | | | | | |

3. Cables

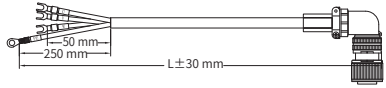
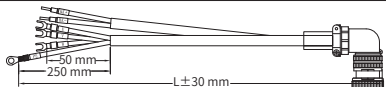
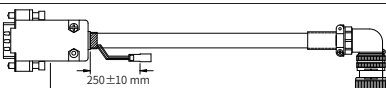
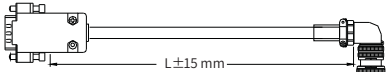
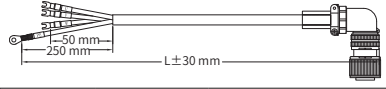
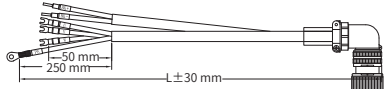
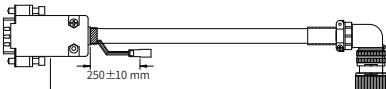
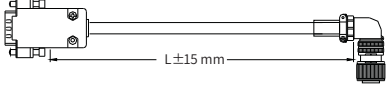
| Motor Model | Flange Size | Cable Name | Cable Model | Length (mm) | Outline Drawing of the Cable | | | | | | | | | |
|---------------------------------------|------------------------------|------------------------------|------------------------------|--|---|---|------------------------------|-------------|----------------|-------------------------|-------------------------|-------------------------|---------|---------|
| MS1H1 and MS1H4 lead wire-type motors | 40 60 80 | Power cable (without brake) | S6-L-M000-3.0-810P | 3000 | | | | | | | | | | |
| | | | S6-L-M000-5.0-810P | 5000 | <table border="1"> <thead> <tr> <th colspan="3">Outer Diameter of the Sheath</th> </tr> <tr> <th>Fixed Cable</th> <th>Flexible Cable</th> <th>Shielded Flexible Cable</th> </tr> </thead> <tbody> <tr> <td>6.5 mm</td> <td>6.5 mm</td> <td>6.5 mm</td> </tr> </tbody> </table> | Outer Diameter of the Sheath | | | Fixed Cable | Flexible Cable | Shielded Flexible Cable | 6.5 mm | 6.5 mm | 6.5 mm |
| | | | Outer Diameter of the Sheath | | | | | | | | | | | |
| | | Fixed Cable | Flexible Cable | Shielded Flexible Cable | | | | | | | | | | |
| | | 6.5 mm | 6.5 mm | 6.5 mm | | | | | | | | | | |
| | | S6-L-M000-10.0-810P | 10000 | | | | | | | | | | | |
| | Power cable (with brake) | S6-L-B000-3.0-810P | 3000 | | | | | | | | | | | |
| | | S6-L-B000-5.0-810P | 5000 | <table border="1"> <thead> <tr> <th colspan="3">Outer Diameter of the Sheath</th> </tr> <tr> <th>Fixed Cable</th> <th>Flexible Cable</th> <th>Shielded Flexible Cable</th> </tr> </thead> <tbody> <tr> <td>6.5 mm</td> <td>6.5 mm</td> <td>6.5 mm</td> </tr> </tbody> </table> | Outer Diameter of the Sheath | | | Fixed Cable | Flexible Cable | Shielded Flexible Cable | 6.5 mm | 6.5 mm | 6.5 mm | |
| | | Outer Diameter of the Sheath | | | | | | | | | | | | |
| | Fixed Cable | Flexible Cable | Shielded Flexible Cable | | | | | | | | | | | |
| | 6.5 mm | 6.5 mm | 6.5 mm | | | | | | | | | | | |
| | S6-L-B000-10.0-810P | 10000 | | | | | | | | | | | | |
| Absolute encoder cable | S6-L-P020-3.0 | 3000 | | | | | | | | | | | | |
| | S6-L-P020-5.0 | 5000 | | | | | | | | | | | | |
| | S6-L-P020-10.0 | 10000 | | The outer diameter of the sheath is 6.0 mm. | | | | | | | | | | |
| Incremental encoder cable | S6-L-P010-3.0 | 3000 | | | | | | | | | | | | |
| | S6-L-P010-5.0 | 5000 | | | | | | | | | | | | |
| | S6-L-P010-10.0 | 10000 | | The outer diameter of the sheath is 6.0 mm. | | | | | | | | | | |
| MS1H2 and MS1H3 connector-type motors | 100 130 | Power cable (without brake) | S6-L-M011-3.0-810P | 3000 | | | | | | | | | | |
| | | | S6-L-M011-5.0-810P | 5000 | | | | | | | | | | |
| | | | S6-L-M011-10.0-810P | 10000 | | <table border="1"> <thead> <tr> <th colspan="3">Outer Diameter of the Sheath</th> </tr> <tr> <th>Fixed Cable</th> <th>Flexible Cable</th> <th>Shielded Flexible Cable</th> </tr> </thead> <tbody> <tr> <td>10.5 mm</td> <td>11.1 mm</td> <td>11.5 mm</td> </tr> </tbody> </table> | Outer Diameter of the Sheath | | | Fixed Cable | Flexible Cable | Shielded Flexible Cable | 10.5 mm | 11.1 mm |
| | | Outer Diameter of the Sheath | | | | | | | | | | | | |
| | | Fixed Cable | Flexible Cable | Shielded Flexible Cable | | | | | | | | | | |
| | | 10.5 mm | 11.1 mm | 11.5 mm | | | | | | | | | | |
| | Power cable (with brake) | S6-L-B011-3.0-810P | 3000 | | | | | | | | | | | |
| | | S6-L-B011-5.0-810P | 5000 | | | | | | | | | | | |
| | | S6-L-B011-10.0-810P | 10000 | | <table border="1"> <thead> <tr> <th colspan="3">Outer Diameter of the Sheath</th> </tr> <tr> <th>Fixed Cable</th> <th>Flexible Cable</th> <th>Shielded Flexible Cable</th> </tr> </thead> <tbody> <tr> <td>10.5 mm</td> <td>11.1 mm</td> <td>11.5 mm</td> </tr> </tbody> </table> | Outer Diameter of the Sheath | | | Fixed Cable | Flexible Cable | Shielded Flexible Cable | 10.5 mm | 11.1 mm | 11.5 mm |
| | Outer Diameter of the Sheath | | | | | | | | | | | | | |
| | Fixed Cable | Flexible Cable | Shielded Flexible Cable | | | | | | | | | | | |
| | 10.5 mm | 11.1 mm | 11.5 mm | | | | | | | | | | | |
| Absolute encoder cable | S6-L-P021-3.0 | 3000 | | | | | | | | | | | | |
| | S6-L-P021-5.0 | 5000 | | | | | | | | | | | | |
| | S6-L-P021-10.0 | 10000 | | The outer diameter of the sheath is 6.0 mm. | | | | | | | | | | |
| Incremental encoder cable | S6-L-P011-3.0 | 3000 | | | | | | | | | | | | |
| | S6-L-P011-5.0 | 5000 | | | | | | | | | | | | |
| | S6-L-P011-10.0 | 10000 | | The outer diameter of the sheath is 6.0 mm. | | | | | | | | | | |

| Motor Model | Flange Size | Cable Name | Cable Model | Length (mm) | Outline Drawing of the Cable | | | | | | | | |
|--|----------------|------------------------------|--|---|--|---|------------------------------|--|--|-------------|----------------|-------------------------|---------|
| MS1H3 connector-type motors (2.9 kW) | 180 | Power cable (without brake) | S6-L-M012-3.0-810P | 3000 |  | | | | | | | | |
| | | | S6-L-M012-5.0-810P | 5000 | | | | | | | | | |
| | | | S6-L-M012-10.0-810P | 10000 | | <table border="1"> <thead> <tr> <th colspan="3">Outer Diameter of the Sheath</th> </tr> <tr> <th>Fixed Cable</th> <th>Flexible Cable</th> <th>Shielded Flexible Cable</th> </tr> </thead> <tbody> <tr> <td>10.5 mm</td> <td>11.1 mm</td> <td>11.5 mm</td> </tr> </tbody> </table> | Outer Diameter of the Sheath | | | Fixed Cable | Flexible Cable | Shielded Flexible Cable | 10.5 mm |
| | | Outer Diameter of the Sheath | | | | | | | | | | | |
| | | Fixed Cable | Flexible Cable | Shielded Flexible Cable | | | | | | | | | |
| | | 10.5 mm | 11.1 mm | 11.5 mm | | | | | | | | | |
| | | Power cable (with brake) | S6-L-B012-3.0-810P | 3000 |  | | | | | | | | |
| | | | S6-L-B012-5.0-810P | 5000 | | | | | | | | | |
| | | | S6-L-B012-10.0-810P | 10000 | | <table border="1"> <thead> <tr> <th colspan="3">Outer Diameter of the Sheath</th> </tr> <tr> <th>Fixed Cable</th> <th>Flexible Cable</th> <th>Shielded Flexible Cable</th> </tr> </thead> <tbody> <tr> <td>10.5 mm</td> <td>11.1 mm</td> <td>11.5 mm</td> </tr> </tbody> </table> | Outer Diameter of the Sheath | | | Fixed Cable | Flexible Cable | Shielded Flexible Cable | 10.5 mm |
| | | Outer Diameter of the Sheath | | | | | | | | | | | |
| | | Fixed Cable | Flexible Cable | Shielded Flexible Cable | | | | | | | | | |
| | | 10.5 mm | 11.1 mm | 11.5 mm | | | | | | | | | |
| Absolute encoder cable | S6-L-P021-3.0 | 3000 |  | | | | | | | | | | |
| | S6-L-P021-5.0 | 5000 | | | | | | | | | | | |
| | S6-L-P021-10.0 | 10000 | | The outer diameter of the sheath is 6.0 mm. | | | | | | | | | |
| Incremental encoder cable | S6-L-P011-3.0 | 3000 |  | | | | | | | | | | |
| | S6-L-P011-5.0 | 5000 | | | | | | | | | | | |
| | S6-L-P011-10.0 | 10000 | | The outer diameter of the sheath is 6.0 mm. | | | | | | | | | |
| MS1H3 connector-type motors (4.4 kW and above) | 180 | Power cable (without brake) | S6-L-M022-3.0-810P | 3000 |  | | | | | | | | |
| | | | S6-L-M022-5.0-810P | 5000 | | | | | | | | | |
| | | | S6-L-M022-10.0-810P | 10000 | | <table border="1"> <thead> <tr> <th colspan="3">Outer Diameter of the Sheath</th> </tr> <tr> <th>Fixed Cable</th> <th>Flexible Cable</th> <th>Shielded Flexible Cable</th> </tr> </thead> <tbody> <tr> <td>12.2 mm</td> <td>12.5 mm</td> <td>13.2 mm</td> </tr> </tbody> </table> | Outer Diameter of the Sheath | | | Fixed Cable | Flexible Cable | Shielded Flexible Cable | 12.2 mm |
| | | Outer Diameter of the Sheath | | | | | | | | | | | |
| | | Fixed Cable | Flexible Cable | Shielded Flexible Cable | | | | | | | | | |
| | | 12.2 mm | 12.5 mm | 13.2 mm | | | | | | | | | |
| | | Power cable (with brake) | S6-L-B022-3.0-810P | 3000 |  | | | | | | | | |
| | | | S6-L-B022-5.0-810P | 5000 | | | | | | | | | |
| | | | S6-L-B022-10.0-810P | 10000 | | <table border="1"> <thead> <tr> <th colspan="3">Outer Diameter of the Sheath</th> </tr> <tr> <th>Fixed Cable</th> <th>Flexible Cable</th> <th>Shielded Flexible Cable</th> </tr> </thead> <tbody> <tr> <td>12.2 mm</td> <td>12.5 mm</td> <td>13.2 mm</td> </tr> </tbody> </table> | Outer Diameter of the Sheath | | | Fixed Cable | Flexible Cable | Shielded Flexible Cable | 12.2 mm |
| | | Outer Diameter of the Sheath | | | | | | | | | | | |
| | | Fixed Cable | Flexible Cable | Shielded Flexible Cable | | | | | | | | | |
| | | 12.2 mm | 12.5 mm | 13.2 mm | | | | | | | | | |
| | | Absolute encoder cable | S6-L-P021-3.0 | 3000 |  | | | | | | | | |
| | | | S6-L-P021-5.0 | 5000 | | | | | | | | | |
| | | | S6-L-P021-10.0 | 10000 | | The outer diameter of the sheath is 6.0 mm. | | | | | | | |
| Incremental encoder cable | S6-L-P011-3.0 | 3000 |  | | | | | | | | | | |
| | S6-L-P011-5.0 | 5000 | | | | | | | | | | | |
| | S6-L-P011-10.0 | 10000 | | The outer diameter of the sheath is 6.0 mm. | | | | | | | | | |

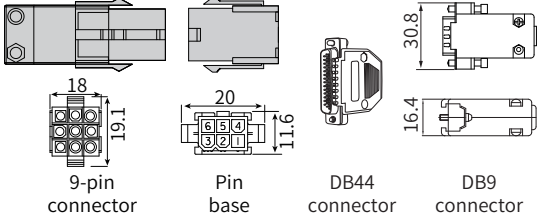
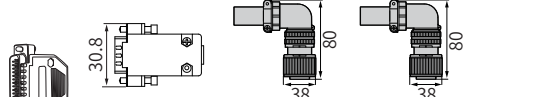
3. Cables

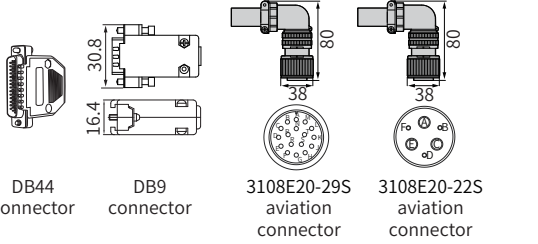
| Applicable Motor | Connector Kit | Outline Drawing and Dimensions |
|---|---------------|---|
| MS1H1/MS1H4 lead wire-type (Z-S) motors | S6-C1 |  <p>9-pin connector Pin base DB44 connector DB9 connector</p> |
| MS1H2 | S6-C2 |  <p>DB44 connector DB9 connector 3108E20-29S aviation connector 3108E20-18S aviation connector</p> |
| MS1H3 (1.8 kW and below) | |  <p>DB44 connector DB9 connector 3108E20-29S aviation connector 3108E20-18S aviation connector</p> |
| MS1MH3 (2.9 kW and above) | S6-C3 |  <p>DB44 connector DB9 connector 3108E20-29S aviation connector 3108E20-22S aviation connector</p> |



◆ Connector kits are needed only when customized cables are used.

3.3.4 SV820N Series Servo Drives

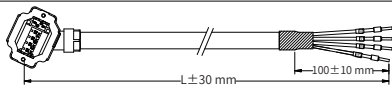
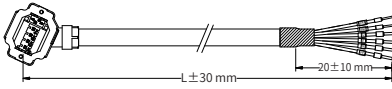
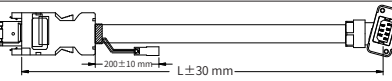
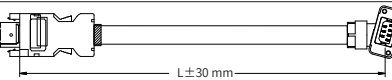
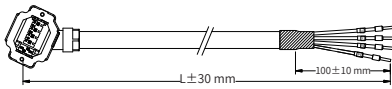
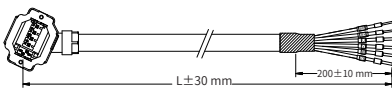
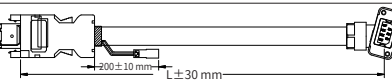
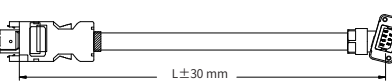
| Motor Model | Flange Size | Cable Name | | Cable Model | Length (mm) | Outline Drawing of the Cable | | | | | | | | |
|--------------------------------------|----------------|--------------|--|---|-------------------------|--|--|------------------------------|--|--|-------------|----------------|-------------------------|--------|
| MS1H1 and MS1H4 terminal-type motors | 40 60 80 | Front outlet | Power cable (without brake) | S6-L-M107-3.0 | 3000 |  | | | | | | | | |
| | | | | S6-L-M107-5.0 | 5000 | | | | | | | | | |
| | | | | S6-L-M107-10.0 | 10000 | | <table border="1"> <thead> <tr> <th colspan="3">Outer Diameter of the Sheath</th> </tr> <tr> <th>Fixed Cable</th> <th>Flexible Cable</th> <th>Shielded Flexible Cable</th> </tr> </thead> <tbody> <tr> <td>6.5 mm</td> <td>6.5 mm</td> <td>6.5 mm</td> </tr> </tbody> </table> | Outer Diameter of the Sheath | | | Fixed Cable | Flexible Cable | Shielded Flexible Cable | 6.5 mm |
| | | | Outer Diameter of the Sheath | | | | | | | | | | | |
| | | | Fixed Cable | Flexible Cable | Shielded Flexible Cable | | | | | | | | | |
| | | | 6.5 mm | 6.5 mm | 6.5 mm | | | | | | | | | |
| | | | Power cable (with brake) | S6-L-B107-3.0 | 3000 |  | | | | | | | | |
| | | | | S6-L-B107-5.0 | 5000 | | | | | | | | | |
| | | | | S6-L-B107-10.0 | 10000 | | <table border="1"> <thead> <tr> <th colspan="3">Outer Diameter of the Sheath</th> </tr> <tr> <th>Fixed Cable</th> <th>Flexible Cable</th> <th>Shielded Flexible Cable</th> </tr> </thead> <tbody> <tr> <td>6.5 mm</td> <td>6.5 mm</td> <td>6.5 mm</td> </tr> </tbody> </table> | Outer Diameter of the Sheath | | | Fixed Cable | Flexible Cable | Shielded Flexible Cable | 6.5 mm |
| | | | Outer Diameter of the Sheath | | | | | | | | | | | |
| | | | Fixed Cable | Flexible Cable | Shielded Flexible Cable | | | | | | | | | |
| | | | 6.5 mm | 6.5 mm | 6.5 mm | | | | | | | | | |
| Absolute encoder cable | S6-L-P124-3.0 | 3000 |  | | | | | | | | | | | |
| | S6-L-P124-5.0 | 5000 | | | | | | | | | | | | |
| | S6-L-P124-10.0 | 10000 | | The outer diameter of the sheath is 6.0 mm. | | | | | | | | | | |
| Incremental encoder cable | S6-L-P114-3.0 | 3000 |  | | | | | | | | | | | |
| | S6-L-P114-3.0 | 5000 | | | | | | | | | | | | |
| | S6-L-P114-3.0 | 10000 | | The outer diameter of the sheath is 6.0 mm. | | | | | | | | | | |
| MS1H1 and MS1H4 terminal-type motors | 40 60 80 | Rear outlet | Power cable (without brake) | S6-L-M108-3.0 | 3000 |  | | | | | | | | |
| | | | | S6-L-M108-5.0 | 5000 | | | | | | | | | |
| | | | | S6-L-M108-10.0 | 10000 | | <table border="1"> <thead> <tr> <th colspan="3">Outer Diameter of the Sheath</th> </tr> <tr> <th>Fixed Cable</th> <th>Flexible Cable</th> <th>Shielded Flexible Cable</th> </tr> </thead> <tbody> <tr> <td>6.5 mm</td> <td>6.5 mm</td> <td>6.5 mm</td> </tr> </tbody> </table> | Outer Diameter of the Sheath | | | Fixed Cable | Flexible Cable | Shielded Flexible Cable | 6.5 mm |
| | | | Outer Diameter of the Sheath | | | | | | | | | | | |
| | | | Fixed Cable | Flexible Cable | Shielded Flexible Cable | | | | | | | | | |
| | | | 6.5 mm | 6.5 mm | 6.5 mm | | | | | | | | | |
| | | | Power cable (with brake) | S6-L-B108-3.0 | 3000 |  | | | | | | | | |
| | | | | S6-L-B108-5.0 | 5000 | | | | | | | | | |
| | | | | S6-L-B108-10.0 | 10000 | | <table border="1"> <thead> <tr> <th colspan="3">Outer Diameter of the Sheath</th> </tr> <tr> <th>Fixed Cable</th> <th>Flexible Cable</th> <th>Shielded Flexible Cable</th> </tr> </thead> <tbody> <tr> <td>6.5 mm</td> <td>6.5 mm</td> <td>6.5 mm</td> </tr> </tbody> </table> | Outer Diameter of the Sheath | | | Fixed Cable | Flexible Cable | Shielded Flexible Cable | 6.5 mm |
| | | | Outer Diameter of the Sheath | | | | | | | | | | | |
| | | | Fixed Cable | Flexible Cable | Shielded Flexible Cable | | | | | | | | | |
| | | | 6.5 mm | 6.5 mm | 6.5 mm | | | | | | | | | |
| Absolute encoder cable | S6-L-P125-3.0 | 3000 |  | | | | | | | | | | | |
| | S6-L-P125-5.0 | 5000 | | | | | | | | | | | | |
| | S6-L-P125-10.0 | 10000 | | The outer diameter of the sheath is 6.0 mm. | | | | | | | | | | |
| Incremental encoder cable | S6-L-P115-3.0 | 3000 |  | | | | | | | | | | | |
| | S6-L-P115-3.0 | 5000 | | | | | | | | | | | | |
| | S6-L-P115-3.0 | 10000 | | The outer diameter of the sheath is 6.0 mm. | | | | | | | | | | |

3. Cables

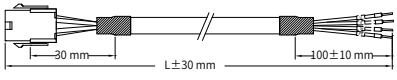
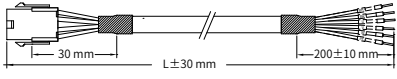
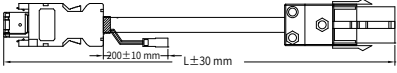
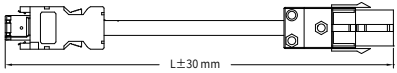
| Motor Model | Flange Size | Cable Name | Cable Model | Length (mm) | Outline Drawing of the Cable | | | | | | |
|---------------------------------------|----------------|-----------------------------|---|-------------------------|--|--|----------------|-------------------------|-------------------------|--------|--------|
| MS1H1 and MS1H4 lead wire-type motors | 40 60 80 | Power cable (without brake) | S6-L-M100-3.0 | 3000 |  <p>Outer Diameter of the Sheath</p> <table border="1"> <tr> <th>Fixed Cable</th> <th>Flexible Cable</th> <th>Shielded Flexible Cable</th> </tr> <tr> <td>6.5 mm</td> <td>6.5 mm</td> <td>6.5 mm</td> </tr> </table> | Fixed Cable | Flexible Cable | Shielded Flexible Cable | 6.5 mm | 6.5 mm | 6.5 mm |
| | | | Fixed Cable | Flexible Cable | | Shielded Flexible Cable | | | | | |
| | | | 6.5 mm | 6.5 mm | | 6.5 mm | | | | | |
| | | | S6-L-M100-5.0 | 5000 | | | | | | | |
| | | | S6-L-M100-10.0 | 10000 | | | | | | | |
| | | | S6-L-B100-3.0 | 3000 | |  <p>Outer Diameter of the Sheath</p> <table border="1"> <tr> <th>Fixed Cable</th> <th>Flexible Cable</th> <th>Shielded Flexible Cable</th> </tr> <tr> <td>6.5 mm</td> <td>6.5 mm</td> <td>6.5 mm</td> </tr> </table> | Fixed Cable | Flexible Cable | Shielded Flexible Cable | 6.5 mm | 6.5 mm |
| | | Fixed Cable | Flexible Cable | Shielded Flexible Cable | | | | | | | |
| | | 6.5 mm | 6.5 mm | 6.5 mm | | | | | | | |
| | | S6-L-B100-5.0 | 5000 | | | | | | | | |
| | | S6-L-B100-10.0 | 10000 | | | | | | | | |
| | | Absolute encoder cable | S6-L-P120-3.0 | 3000 |  <p>The outer diameter of the sheath is 6.0 mm.</p> | | | | | | |
| | | | S6-L-P120-5.0 | 5000 | | | | | | | |
| S6-L-P120-10.0 | 10000 | | | | | | | | | | |
| Incremental encoder cable | S6-L-P110-3.0 | 3000 |  <p>The outer diameter of the sheath is 6.0 mm.</p> | | | | | | | | |
| | S6-L-P110-5.0 | 5000 | | | | | | | | | |
| | S6-L-P110-10.0 | 10000 | | | | | | | | | |

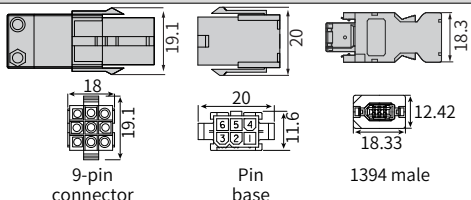
| Applicable Motor | Connector Kit | Outline Drawing and Dimensions |
|---|---------------|---|
| MS1H1/MS1H4 lead wire-type (Z-S) motors | S6-C26 |  <p>9-pin connector: 18 mm width, 19.1 mm height</p> <p>Pin base: 20 mm width, 11.6 mm height</p> <p>1394 male: 18.33 mm width, 12.42 mm height, 18.3 mm total height</p> |



◆ Connector kits are needed only when customized cables are used.

3.3.5 SV660P/N Series Servo Drives

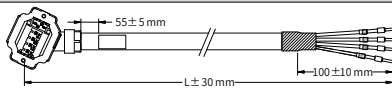
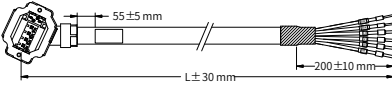
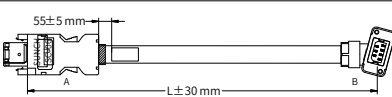
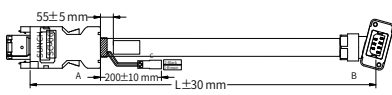
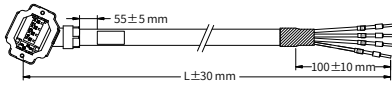
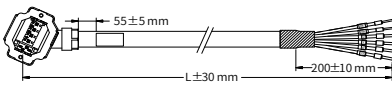
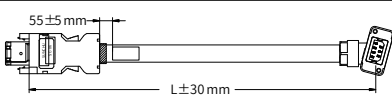
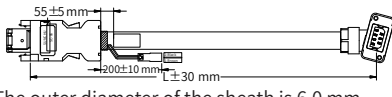
| Motor Model | Flange Size | Cable Name | | Cable Model | Length (mm) | Outline Drawing of the Cable | | | | | | | | |
|--------------------------------------|---------------------------|------------------------------|--|--|--|--|------------------------------|-------------|----------------|-------------------------|-------------------------|-------------------------|--------|--------|
| MS1H1 and MS1H4 terminal-type motors | 40 60 80 | Front outlet | Power cable (without brake) | S6-L-M107-3.0 | 3000 |  | | | | | | | | |
| | | | | S6-L-M107-5.0 | 5000 | | | | | | | | | |
| | | | | S6-L-M107-10.0 | 10000 | <table border="1"> <thead> <tr> <th colspan="3">Outer Diameter of the Sheath</th> </tr> </thead> <tbody> <tr> <td>Fixed Cable</td> <td>Flexible Cable</td> <td>Shielded Flexible Cable</td> </tr> <tr> <td>6.5 mm</td> <td>6.5 mm</td> <td>6.5 mm</td> </tr> </tbody> </table> | Outer Diameter of the Sheath | | | Fixed Cable | Flexible Cable | Shielded Flexible Cable | 6.5 mm | 6.5 mm |
| | | | Outer Diameter of the Sheath | | | | | | | | | | | |
| | | | Fixed Cable | Flexible Cable | Shielded Flexible Cable | | | | | | | | | |
| | | | 6.5 mm | 6.5 mm | 6.5 mm | | | | | | | | | |
| | | Power cable (with brake) | S6-L-B107-3.0 | 3000 |  | | | | | | | | | |
| | | | S6-L-B107-5.0 | 5000 | | | | | | | | | | |
| | | | S6-L-B107-10.0 | 10000 | <table border="1"> <thead> <tr> <th colspan="3">Outer Diameter of the Sheath</th> </tr> </thead> <tbody> <tr> <td>Fixed Cable</td> <td>Flexible Cable</td> <td>Shielded Flexible Cable</td> </tr> <tr> <td>6.5 mm</td> <td>6.5 mm</td> <td>6.5 mm</td> </tr> </tbody> </table> | Outer Diameter of the Sheath | | | Fixed Cable | Flexible Cable | Shielded Flexible Cable | 6.5 mm | 6.5 mm | 6.5 mm |
| | | Outer Diameter of the Sheath | | | | | | | | | | | | |
| | | Fixed Cable | Flexible Cable | Shielded Flexible Cable | | | | | | | | | | |
| | | 6.5 mm | 6.5 mm | 6.5 mm | | | | | | | | | | |
| | Incremental encoder cable | S6-L-P114-3.0 | 3000 |  | | | | | | | | | | |
| | | S6-L-P114-5.0 | 5000 | | | | | | | | | | | |
| | | S6-L-P114-10.0 | 10000 | The outer diameter of the sheath is 6.0 mm. | | | | | | | | | | |
| | Absolute encoder cable | S6-L-P124-3.0 | 3000 |  | | | | | | | | | | |
| | | S6-L-P124-5.0 | 5000 | | | | | | | | | | | |
| | | S6-L-P124-10.0 | 10000 | The outer diameter of the sheath is 6.0 mm. | | | | | | | | | | |
| | 40 60 80 | Rear outlet | Power cable (without brake) | S6-L-M108-3.0 | 3000 |  | | | | | | | | |
| | | | | S6-L-M108-5.0 | 5000 | | | | | | | | | |
| | | | | S6-L-M108-10.0 | 10000 | <table border="1"> <thead> <tr> <th colspan="3">Outer Diameter of the Sheath</th> </tr> </thead> <tbody> <tr> <td>Fixed Cable</td> <td>Flexible Cable</td> <td>Shielded Flexible Cable</td> </tr> <tr> <td>6.5 mm</td> <td>6.5 mm</td> <td>6.5 mm</td> </tr> </tbody> </table> | Outer Diameter of the Sheath | | | Fixed Cable | Flexible Cable | Shielded Flexible Cable | 6.5 mm | 6.5 mm |
| | | | Outer Diameter of the Sheath | | | | | | | | | | | |
| | | | Fixed Cable | Flexible Cable | Shielded Flexible Cable | | | | | | | | | |
| | | | 6.5 mm | 6.5 mm | 6.5 mm | | | | | | | | | |
| Power cable (with brake) | | S6-L-B108-3.0 | 3000 |  | | | | | | | | | | |
| | | S6-L-B108-5.0 | 5000 | | | | | | | | | | | |
| | | S6-L-B108-10.0 | 10000 | <table border="1"> <thead> <tr> <th colspan="3">Outer Diameter of the Sheath</th> </tr> </thead> <tbody> <tr> <td>Fixed Cable</td> <td>Flexible Cable</td> <td>Shielded Flexible Cable</td> </tr> <tr> <td>6.5 mm</td> <td>6.5 mm</td> <td>6.5 mm</td> </tr> </tbody> </table> | Outer Diameter of the Sheath | | | Fixed Cable | Flexible Cable | Shielded Flexible Cable | 6.5 mm | 6.5 mm | 6.5 mm | |
| Outer Diameter of the Sheath | | | | | | | | | | | | | | |
| Fixed Cable | | Flexible Cable | Shielded Flexible Cable | | | | | | | | | | | |
| 6.5 mm | | 6.5 mm | 6.5 mm | | | | | | | | | | | |
| Incremental encoder cable | S6-L-P115-3.0 | 3000 |  | | | | | | | | | | | |
| | S6-L-P115-5.0 | 5000 | | | | | | | | | | | | |
| | S6-L-P115-10.0 | 10000 | The outer diameter of the sheath is 6.0 mm. | | | | | | | | | | | |
| Absolute encoder cable | S6-L-P125-3.0 | 3000 |  | | | | | | | | | | | |
| | S6-L-P125-5.0 | 5000 | | | | | | | | | | | | |
| | S6-L-P125-10.0 | 10000 | The outer diameter of the sheath is 6.0 mm. | | | | | | | | | | | |

3. Cables

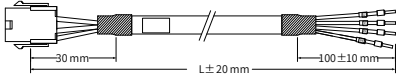
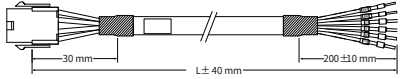
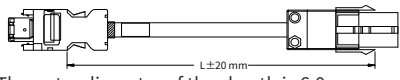
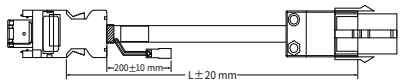
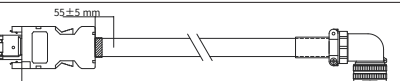
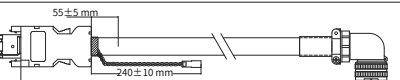
| Motor Model | Flange Size | Cable Name | Cable Model | Length (mm) | Outline Drawing of the Cable | | | | | | | | | |
|---------------------------------------|--------------------------|------------------------------|---|--|--|------------------------------|--|-------------|----------------|-------------------------|-------------------------|--------|--------|--------|
| MS1H1 and MS1H4 lead wire-type motors | 40 60 80 | Power cable (without brake) | S6-L-M100-3.0 | 3000 |  <table border="1" data-bbox="613 271 1013 351"> <thead> <tr> <th colspan="3">Outer Diameter of the Sheath</th> </tr> <tr> <th>Fixed Cable</th> <th>Flexible Cable</th> <th>Shielded Flexible Cable</th> </tr> </thead> <tbody> <tr> <td>6.5 mm</td> <td>6.5 mm</td> <td>6.5 mm</td> </tr> </tbody> </table> | Outer Diameter of the Sheath | | | Fixed Cable | Flexible Cable | Shielded Flexible Cable | 6.5 mm | 6.5 mm | 6.5 mm |
| | | | Outer Diameter of the Sheath | | | | | | | | | | | |
| | | | Fixed Cable | Flexible Cable | | Shielded Flexible Cable | | | | | | | | |
| | | 6.5 mm | 6.5 mm | 6.5 mm | | | | | | | | | | |
| | | S6-L-M100-5.0 | 5000 | | | | | | | | | | | |
| | | S6-L-M100-10.0 | 10000 | | | | | | | | | | | |
| | Power cable (with brake) | S6-L-B100-3.0 | 3000 |  <table border="1" data-bbox="613 454 1013 534"> <thead> <tr> <th colspan="3">Outer Diameter of the Sheath</th> </tr> <tr> <th>Fixed Cable</th> <th>Flexible Cable</th> <th>Shielded Flexible Cable</th> </tr> </thead> <tbody> <tr> <td>6.5 mm</td> <td>6.5 mm</td> <td>6.5 mm</td> </tr> </tbody> </table> | Outer Diameter of the Sheath | | | Fixed Cable | Flexible Cable | Shielded Flexible Cable | 6.5 mm | 6.5 mm | 6.5 mm | |
| | | Outer Diameter of the Sheath | | | | | | | | | | | | |
| | | Fixed Cable | Flexible Cable | | Shielded Flexible Cable | | | | | | | | | |
| | 6.5 mm | 6.5 mm | 6.5 mm | | | | | | | | | | | |
| | S6-L-B100-5.0 | 5000 | | | | | | | | | | | | |
| | S6-L-B100-10.0 | 10000 | | | | | | | | | | | | |
| Incremental encoder cable | S6-L-P110-3.0 | 3000 |  <p>The outer diameter of the sheath is 6.0 mm.</p> | | | | | | | | | | | |
| | S6-L-P110-5.0 | 5000 | | | | | | | | | | | | |
| | S6-L-P110-10.0 | 10000 | | | | | | | | | | | | |
| Absolute encoder cable | S6-L-P120-3.0 | 3000 |  <p>The outer diameter of the sheath is 6.0 mm.</p> | | | | | | | | | | | |
| | S6-L-P120-5.0 | 5000 | | | | | | | | | | | | |
| | S6-L-P120-10.0 | 10000 | | | | | | | | | | | | |
| MS1H2 and MS1H3 motors | 100 130 180 | Incremental encoder cable | S6-L-P111-3.0 | 3000 |  <p>The outer diameter of the sheath is 6.0 mm.</p> | | | | | | | | | |
| | | | S6-L-P111-5.0 | 5000 | | | | | | | | | | |
| | | | S6-L-P111-10.0 | 10000 | | | | | | | | | | |
| | Absolute encoder cable | S6-L-P121-3.0 | 3000 |  <p>The outer diameter of the sheath is 6.0 mm.</p> | | | | | | | | | | |
| | | S6-L-P121-5.0 | 5000 | | | | | | | | | | | |
| | | S6-L-P121-10.0 | 10000 | | | | | | | | | | | |

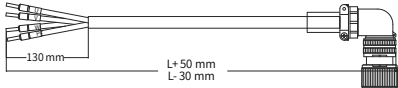
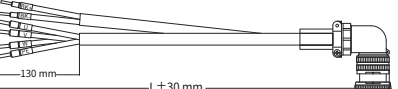
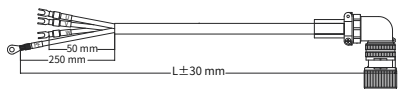
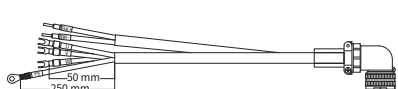
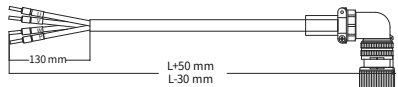
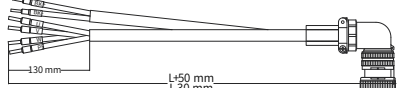
| Motor Model | Flange Size | Cable Name | Cable Model | Length (mm) | Outline Drawing of the Cable | | | | | | |
|---|----------------|------------------------------|----------------|-------------|--|-------------|----------------|-------------------------|---------|---------|---------|
| MS1H2 motors (3 kW and below) and MS1H3 motors (1.8 kW and below) | 100 130 | Power cable (without brake) | S6-L-M111-3.0 | 3000 |  <p>130 mm L+50 mm L-30 mm</p> | | | | | | |
| | | | S6-L-M111-5.0 | 5000 | | | | | | | |
| | | | S6-L-M111-10.0 | 10000 | | | | | | | |
| | | Power cable (with brake) | S6-L-B111-3.0 | 3000 |  <p>130 mm L±30 mm</p> | | | | | | |
| | | | S6-L-B111-5.0 | 5000 | | | | | | | |
| | | | S6-L-B111-10.0 | 10000 | | | | | | | |
| | | Outer Diameter of the Sheath | | | <table border="1"> <tr> <td>Fixed Cable</td> <td>Flexible Cable</td> <td>Shielded Flexible Cable</td> </tr> <tr> <td>9.5 mm</td> <td>10.2 mm</td> <td>10.6 mm</td> </tr> </table> | Fixed Cable | Flexible Cable | Shielded Flexible Cable | 9.5 mm | 10.2 mm | 10.6 mm |
| Fixed Cable | Flexible Cable | Shielded Flexible Cable | | | | | | | | | |
| 9.5 mm | 10.2 mm | 10.6 mm | | | | | | | | | |
| | | Outer Diameter of the Sheath | | | <table border="1"> <tr> <td>Fixed Cable</td> <td>Flexible Cable</td> <td>Shielded Flexible Cable</td> </tr> <tr> <td>9.5 mm</td> <td>10.2 mm</td> <td>10.6 mm</td> </tr> </table> | Fixed Cable | Flexible Cable | Shielded Flexible Cable | 9.5 mm | 10.2 mm | 10.6 mm |
| Fixed Cable | Flexible Cable | Shielded Flexible Cable | | | | | | | | | |
| 9.5 mm | 10.2 mm | 10.6 mm | | | | | | | | | |
| MS1H2 motors (4 kW/ 5 kW) | 130 | Power cable (without brake) | S6-L-M011-3.0 | 3000 |  <p>50 mm L±30 mm 250 mm</p> | | | | | | |
| | | | S6-L-M011-5.0 | 5000 | | | | | | | |
| | | | S6-L-M011-10.0 | 10000 | | | | | | | |
| | | Power cable (with brake) | S6-L-B011-3.0 | 3000 |  <p>50 mm L+50 mm 250 mm L-30 mm</p> | | | | | | |
| | | | S6-L-B011-5.0 | 5000 | | | | | | | |
| | | | S6-L-B011-10.0 | 10000 | | | | | | | |
| | | Outer Diameter of the Sheath | | | <table border="1"> <tr> <td>Fixed Cable</td> <td>Flexible Cable</td> <td>Shielded Flexible Cable</td> </tr> <tr> <td>10.5 mm</td> <td>11.1 mm</td> <td>11.5 mm</td> </tr> </table> | Fixed Cable | Flexible Cable | Shielded Flexible Cable | 10.5 mm | 11.1 mm | 11.5 mm |
| Fixed Cable | Flexible Cable | Shielded Flexible Cable | | | | | | | | | |
| 10.5 mm | 11.1 mm | 11.5 mm | | | | | | | | | |
| | | Outer Diameter of the Sheath | | | <table border="1"> <tr> <td>Fixed Cable</td> <td>Flexible Cable</td> <td>Shielded Flexible Cable</td> </tr> <tr> <td>10.5 mm</td> <td>11.1 mm</td> <td>11.5 mm</td> </tr> </table> | Fixed Cable | Flexible Cable | Shielded Flexible Cable | 10.5 mm | 11.1 mm | 11.5 mm |
| Fixed Cable | Flexible Cable | Shielded Flexible Cable | | | | | | | | | |
| 10.5 mm | 11.1 mm | 11.5 mm | | | | | | | | | |
| MS1H3 motors (2.9 kW) | 180 | Power cable (without brake) | S6-L-M112-3.0 | 3000 |  <p>130 mm L+50 mm L-30 mm</p> | | | | | | |
| | | | S6-L-M112-5.0 | 5000 | | | | | | | |
| | | | S6-L-M112-10.0 | 10000 | | | | | | | |
| | | Power cable (with brake) | S6-L-B112-3.0 | 3000 |  <p>130 mm L+50 mm L-30 mm</p> | | | | | | |
| | | | S6-L-B112-5.0 | 5000 | | | | | | | |
| | | | S6-L-B112-10.0 | 10000 | | | | | | | |
| | | Outer Diameter of the Sheath | | | <table border="1"> <tr> <td>Fixed Cable</td> <td>Flexible Cable</td> <td>Shielded Flexible Cable</td> </tr> <tr> <td>9.5 mm</td> <td>10.2 mm</td> <td>10.6 mm</td> </tr> </table> | Fixed Cable | Flexible Cable | Shielded Flexible Cable | 9.5 mm | 10.2 mm | 10.6 mm |
| Fixed Cable | Flexible Cable | Shielded Flexible Cable | | | | | | | | | |
| 9.5 mm | 10.2 mm | 10.6 mm | | | | | | | | | |
| | | Outer Diameter of the Sheath | | | <table border="1"> <tr> <td>Fixed Cable</td> <td>Flexible Cable</td> <td>Shielded Flexible Cable</td> </tr> <tr> <td>9.5 mm</td> <td>10.2 mm</td> <td>10.6 mm</td> </tr> </table> | Fixed Cable | Flexible Cable | Shielded Flexible Cable | 9.5 mm | 10.2 mm | 10.6 mm |
| Fixed Cable | Flexible Cable | Shielded Flexible Cable | | | | | | | | | |
| 9.5 mm | 10.2 mm | 10.6 mm | | | | | | | | | |

3. Cables

| Motor Model | Flange Size | Cable Name | Cable Model | Length (mm) | Outline Drawing of the Cable | | | | | | | | | |
|---------------------------------|----------------|-----------------------------|----------------|-------------|---|------------------------------|--|--|-------------|----------------|-------------------------|---------|---------|---------|
| MS1H3 motors (4.4 kW and above) | 180 | Power cable (without brake) | S6-L-M022-3.0 | 3000 | | | | | | | | | | |
| | | | S6-L-M022-5.0 | 5000 | | | | | | | | | | |
| | | | S6-L-M022-10.0 | 10000 | | | | | | | | | | |
| | | Power cable (with brake) | S6-L-B022-3.0 | 3000 | | | | | | | | | | |
| | | | S6-L-B022-5.0 | 5000 | | | | | | | | | | |
| | | | S6-L-B022-10.0 | 10000 | | | | | | | | | | |
| | | | | | <table border="1"> <thead> <tr> <th colspan="3">Outer Diameter of the Sheath</th> </tr> <tr> <th>Fixed Cable</th> <th>Flexible Cable</th> <th>Shielded Flexible Cable</th> </tr> </thead> <tbody> <tr> <td>12.2 mm</td> <td>12.5 mm</td> <td>13.2 mm</td> </tr> </tbody> </table> | Outer Diameter of the Sheath | | | Fixed Cable | Flexible Cable | Shielded Flexible Cable | 12.2 mm | 12.5 mm | 13.2 mm |
| Outer Diameter of the Sheath | | | | | | | | | | | | | | |
| Fixed Cable | Flexible Cable | Shielded Flexible Cable | | | | | | | | | | | | |
| 12.2 mm | 12.5 mm | 13.2 mm | | | | | | | | | | | | |
| | | | | | <table border="1"> <thead> <tr> <th colspan="3">Outer Diameter of the Sheath</th> </tr> <tr> <th>Fixed Cable</th> <th>Flexible Cable</th> <th>Shielded Flexible Cable</th> </tr> </thead> <tbody> <tr> <td>12.2 mm</td> <td>12.5 mm</td> <td>13.2 mm</td> </tr> </tbody> </table> | Outer Diameter of the Sheath | | | Fixed Cable | Flexible Cable | Shielded Flexible Cable | 12.2 mm | 12.5 mm | 13.2 mm |
| Outer Diameter of the Sheath | | | | | | | | | | | | | | |
| Fixed Cable | Flexible Cable | Shielded Flexible Cable | | | | | | | | | | | | |
| 12.2 mm | 12.5 mm | 13.2 mm | | | | | | | | | | | | |

| Applicable Motor | Connector Kit | Outline Drawing and Dimensions |
|---|---------------|--|
| MS1H1/MS1H4 lead wire-type (Z-S) motors | S6-C26 | <p>9-pin connector Pin base 1394 male</p> |
| MS1H2/MS1H3 (1.8 kW and below) | S6-C29 | <p>1394 male Aviation connector Aviation connector</p> |
| MS1H3 (2.9 kW and above) | S6-C39 | <p>1394 male Aviation connector Aviation connector</p> |



◆ Connector kits are needed only when customized cables are used.

3.4 Cable Connections

3.4.1 Connecting Motor Power Cables

1 Connecting to IS620 series servo drives

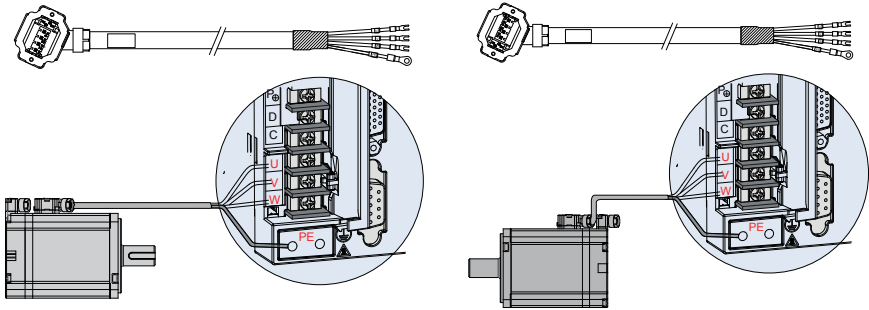

Motor cable outlet direction: front outlet

Motor cable outlet direction: rear outlet

Figure 3-3 Connection between IS620 series servo drive and servo motor

Table 3-1 Power cable connector of terminal-type servo motors (motor side)

| Applicable Motor Flange Size ^[1] | Outline Drawing of the Connector | Terminal Pin Layout | | |
|--|--|---------------------|-------------|--------------|
| | | Pin No. | Signal Name | Color |
| Terminal-type motors: 40 (Z series) 60 (Z series) 80 (Z series) |  <p>SDC-06T (manufacturer: JONHON)</p> | 1 | PE | Yellow/Green |
| | | 2 | W | Red |
| | | 3 | V | Black |
| | | 4 | U | White |
| | | 5 | Brake + | Brown |
| | | 6 | Brake - | Blue |

Table 3-2 Power cable connector of connector-type servo motors (motor side)

| Applicable Motor Flange Size ^[1] | Outline Drawing of the Connector | Terminal Pin Layout | | |
|---|---|---------------------|-------------|--------------|
| | | New Structure | | Color |
| | | Pin No. | Signal Name | |
| Connector-type motors: 100 130 |  <p>20-18 aviation connector</p> <p>MIL-DTL-5015 series 3108E20-18S aviation connector</p> | B | U | Blue |
| | | I | V | Black |
| | | F | W | Red |
| | | G | PE | Yellow/Green |
| | | C | Brake (+) | - |
| | | E | Brake (-) | - |

Table 3-3 Power cable connector of connector-type servo motors (motor side)

| Applicable Motor Flange Size ^[1] | Outline Drawing of the Connector | Pin Layout | | |
|---|---|------------|-------------|--------------|
| | | Pin No. | Signal Name | Color |
| Connector-type motors: 180 |  <p>20-22 aviation connector</p> <p>MIL-DTL-5015 series 3108E20-22S aviation connector</p> | A | U | Blue |
| | | C | V | Black |
| | | E | W | Red |
| | | F | PE | Yellow/Green |
| | | B | Brake (-) | - |
| | | D | Brake (+) | |

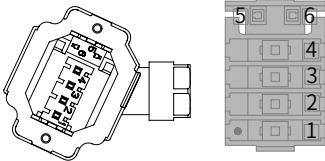

◆ The flange size refers to the width of the mounting flange.
 ◆ Power cable colors are subject to the actual cables. Cable colors mentioned in this user guide all refer to Inovance cables.

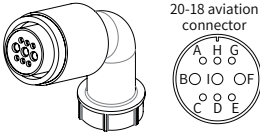
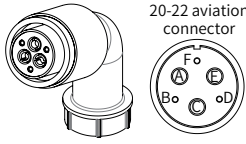
2 Connecting to IS810N-INT series servo drives

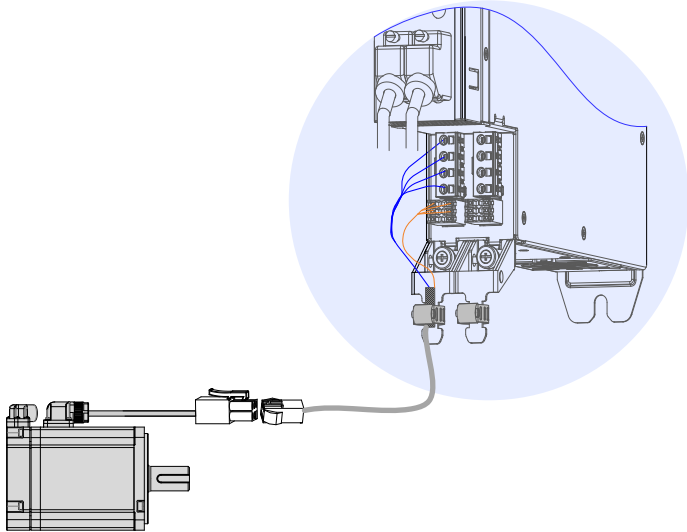

Figure 3-4 Connection between IS810-INT series servo drive and servo motor

Table 3-4 Power cable connector of terminal-type and lead wire-type servo motors (motor side)

| Applicable Motor Flange Size ^[1] | Outline Drawing of the Connector | Terminal Pin Layout | | |
|---|--|---------------------|-------------------------------|------------------|
| | | Pin No. | Signal Name | Color |
| Terminal-type motors: 40 (Z series) 60 (Z series) 80 (Z series) |  <p>SDC-06T (manufacturer: JONHON)</p> | 1 | PE | Yellow/ Green |
| | | 2 | W | Red |
| | | 3 | V | Black |
| | | 4 | U | White |
| | | 5 | Brake Polarity insensitive | Brown |
| | | 6 | | Blue |
| Lead wire-type motors: 40 (Z-S series) 60 (Z-S series) 80 (Z-S series) |  <p>Black 6-pin connector</p> <p>Recommendation: Plastic housing: MOLEX-50361736 Terminal: MOLEX-39000061</p> | 1 | U | White |
| | | 2 | V | Black |
| | | 4 | W | Red |
| | | 5 | PE | Yellow/ Green |
| | | 3 | Brake (polarity insensitive) | - |
| | | 6 | | - |

Table 3-5 Power cable connector of connector-type servo motors (motor side)

| Applicable Motor Flange Size ^[1] | Outline Drawing of the Connector | Terminal Pin Layout | | |
|---|--|---------------------|-------------|--------------|
| | | Pin No. | Signal Name | Color |
| Connector-type motors: 100 130 |  <p>20-18 aviation connector</p> <p>MIL-DTL-5015 series 3108E20-18S aviation connector</p> | B | U | Blue |
| | | I | V | Black |
| | | F | W | Red |
| | | G | PE | Yellow/Green |
| | | C | Brake (+) | - |
| | | E | Brake (-) | - |

Table 3-6 Power cable connector of connector-type servo motors (motor side)

| Applicable Motor Flange Size ^[1] | Outline Drawing of the Connector | Pin Layout | | |
|---|---|------------|-------------|--------------|
| | | Pin No. | Signal Name | Color |
| Connector-type motors: 180 |  <p>20-22 aviation connector</p> <p>MIL-DTL-5015 series 3108E20-22S aviation connector</p> | A | U | Blue |
| | | C | V | Black |
| | | E | W | Red |
| | | F | PE | Yellow/Green |
| | | B | Brake (-) | - |
| | | D | Brake (+) | |

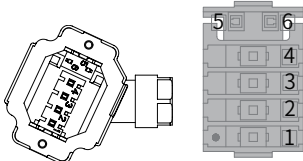
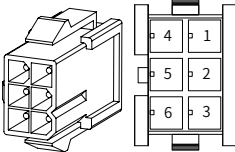

- ◆ The flange size refers to the width of the mounting flange.
- ◆ Power cable colors are subject to the actual cables. Cable colors mentioned in this user guide all refer to Inovance cables.

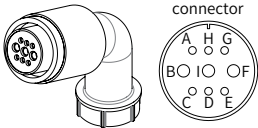
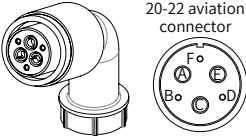
3 Connecting to IS810P series servo drives

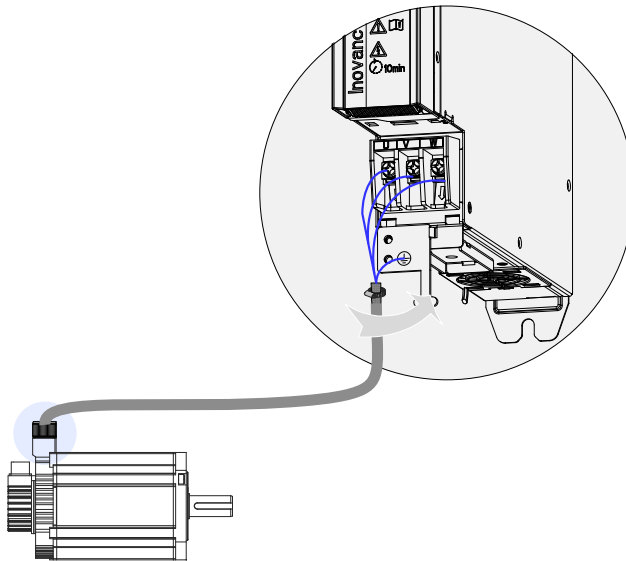

Figure 3-5 Connection between IS810P series servo drive and servo motor

Table 3-7 Power cable connectors of terminal-type and lead wire-type servo motors (motor side)

| Applicable Motor Flange Size ^[1] | Outline Drawing of the Connector | Terminal Pin Layout | | |
|---|--|---------------------|---------------------------------|------------------|
| | | Pin No. | Signal Name | Color |
| Terminal-type motors: 40 (Z series) 60 (Z series) 80 (Z series) |  <p>SDC-06T (manufacturer: JONHON)</p> | 1 | PE | Yellow/ Green |
| | | 2 | W | Red |
| | | 3 | V | Black |
| | | 4 | U | White |
| | | 5 | Brake + | Brown |
| | | 6 | Brake - | Blue |
| Lead wire-type motors: 40 (Z-S series) 60 (Z-S series) 80 (Z-S series) |  <p>Black 6-pin connector</p> <p>Recommendation: Plastic housing: MOLEX-50361736 Terminal: MOLEX-39000061</p> | 1 | U | White |
| | | 2 | V | Black |
| | | 4 | W | Red |
| | | 5 | PE | Yellow/ Green |
| | | 3 | Brake (polarity insensitive) | - |
| | | 6 | | |

Table 3-8 Power cable connector of connector-type servo motors (motor side)

| Applicable Motor Flange Size ^[1] | Outline Drawing of the Connector | Terminal Pin Layout | | |
|---|--|---------------------|-------------|--------------|
| | | New Structure | | Color |
| | | Pin No. | Signal Name | |
| Connector-type motors: 100 130 |  <p>20-18 aviation connector</p> <p>MIL-DTL-5015 series 3108E20-18S aviation connector</p> | B | U | Blue |
| | | I | V | Black |
| | | F | W | Red |
| | | G | PE | Yellow/Green |
| | | C | Brake (+) | - |
| | | E | Brake (-) | - |

Table 3-9 Power cable connector of connector-type servo motors (motor side)

| Applicable Motor Flange Size ^[1] | Outline Drawing of the Connector | Pin Layout | | |
|---|---|------------|-------------|--------------|
| | | Pin No. | Signal Name | Color |
| Connector-type motors: 180 |  <p>20-22 aviation connector</p> <p>MIL-DTL-5015 series 3108E20-22S aviation connector</p> | A | U | Blue |
| | | C | V | Black |
| | | E | W | Red |
| | | F | PE | Yellow/Green |
| | | B | Brake (-) | - |
| | | D | Brake (+) | |

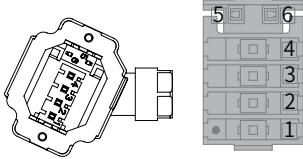
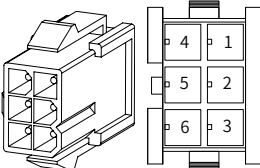

- ◆ The flange size refers to the width of the mounting flange.
- ◆ Power cable colors are subject to the actual cables. Cable colors mentioned in this user guide all refer to Inovance cables.

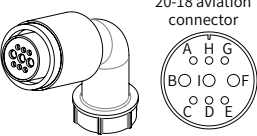
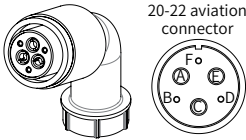
4 Connecting to SV820N series servo drives

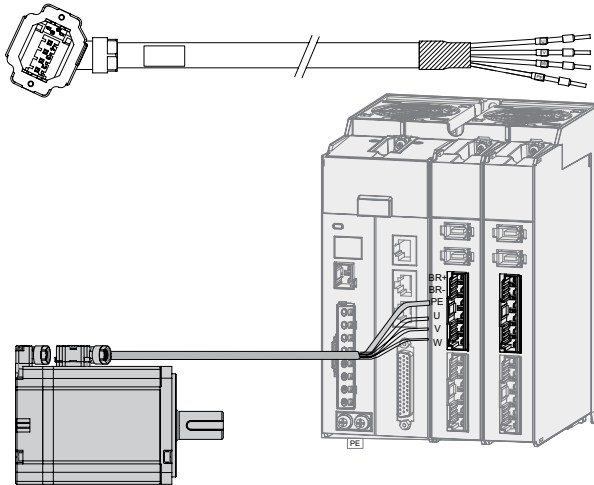
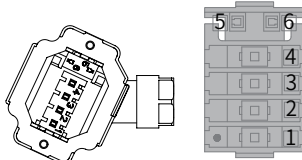
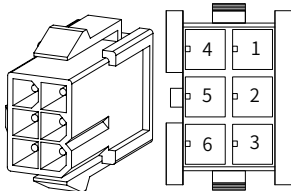

Figure 3-6 Connection between SV820N series servo drive and servo motor

Table 3-10 Power cable connectors of lead wire-type and terminal-type servo motors (motor side)

| Applicable Motor Flange Size ^[1] | Outline Drawing of the Connector | Terminal Pin Layout | | |
|---|--|---------------------|-------------|---------------|
| | | Pin No. | Signal Name | Color |
| Terminal-type motors: 40 (Z series) 60 (Z series) 80 (Z series) |  <p>SDC-06T (manufacturer: JONHON)</p> | 1 | PE | Yellow/ Green |
| | | 2 | W | Red |
| | | 3 | V | Black |
| | | 4 | U | White |
| | | 5 | Brake + | Brown |
| | | 6 | Brake - | Blue |
| Lead wire-type motors: 40 (Z-S series) 60 (Z-S series) 80 (Z-S series) |  <p>Black 6-pin connector</p> <p>Recommendation: Plastic housing: MOLEX-50361736 Terminal: MOLEX-39000061</p> | 1 | U | White |
| | | 2 | V | Black |
| | | 4 | W | Red |
| | | 5 | PE | Yellow/ Green |
| | | 3 | Brake + | Brown |
| | | 6 | Brake - | Blue |

5 Connecting to SV660 series servo drives

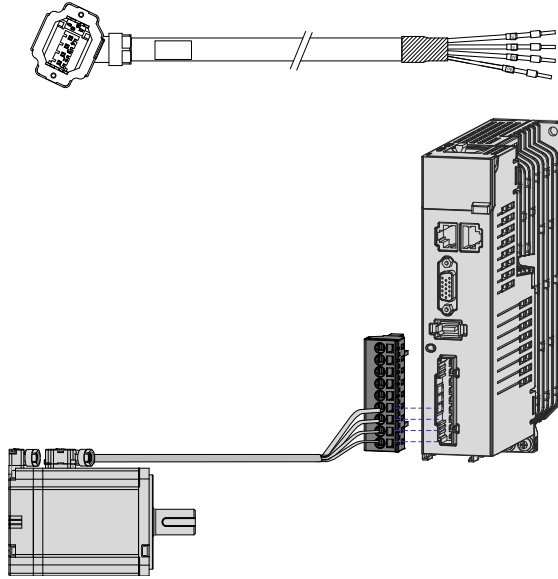
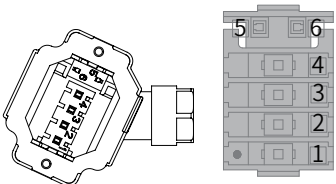

Figure 3-7 Connection between SV660 series servo drive and terminal-type servo motor

Table 3-11 Power cable connector of terminal-type servo motors (motor side)

| Applicable Motor Flange Size ^[1] | Outline Drawing of the Connector | Terminal Pin Layout | | |
|--|--|---------------------|-------------|---------------|
| | | Pin No. | Signal Name | Color |
| Terminal-type motors: 40 (Z series) 60 (Z series) 80 (Z series) |  <p>SDC-06T (manufacturer: JONHON)</p> | 1 | PE | Yellow/ Green |
| | | 2 | W | Red |
| | | 3 | V | Black |
| | | 4 | U | White |
| | | 5 | Brake + | Brown |
| | | 6 | Brake - | Blue |



- ◆ The flange size refers to the width of the mounting flange.
- ◆ Power cable colors are subject to the actual cables. Cable colors mentioned in this user guide all refer to Inovance cables.

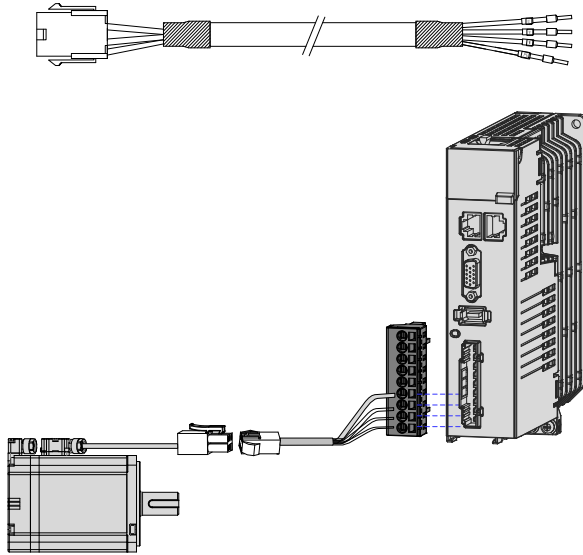

Figure 3-8 Connection between SV660 series servo drive and lead wire-type servo motor

Table 3-12 Power cable connector of lead wire-type servo motors (motor side)

| Applicable Motor Flange Size ^[1] | Outline Drawing of the Connector | Terminal Pin Layout | | |
|---|---|---------------------|---------------------------------|------------------|
| | | Pin No. | Signal Name | Color |
| Lead wire-type motors: 40 (Z-S series) 60 (Z-S series) 80 (Z-S series) |  <p>Black 6-pin connector</p> <p>Recommendation: Plastic housing: MOLEX-50361736 Terminal: MOLEX-39000061</p> | 1 | U | White |
| | | 2 | V | Black |
| | | 4 | W | Red |
| | | 5 | PE | Yellow/ Green |
| | | 3 | Brake (polarity insensitive) | - |
| | | 6 | | |

Table 3-13 Power cable connector of connector-type servo motors (motor side)

| Applicable Motor Flange Size ^[1] | Outline Drawing of the Connector | Terminal Pin Layout | | |
|---|---|---------------------|-------------|--------------|
| | | Pin No. | Signal Name | Color |
| Connector-type motors: 100 130 |  <p>20-18 aviation connector</p> <p>MIL-DTL-5015 series 3108E20-18S aviation connector</p> | B | U | Blue |
| | | I | V | Black |
| | | F | W | Red |
| | | G | PE | Yellow/Green |
| | | C | Brake (+) | - |
| | | E | Brake (-) | - |

Table 3-14 Power cable connector of connector-type servo motors (motor side)

| Applicable Motor Flange Size ^[1] | Outline Drawing of the Connector | Terminal Layout | | |
|---|---|-----------------|------------------------------|--------------|
| | | Pin No. | Signal Name | Color |
| Connector-type motors: 180 |  <p>20-22 aviation connector</p> <p>MIL-DTL-5015 series 3108E20-22S aviation connector</p> | A | U | Blue |
| | | C | V | Black |
| | | E | W | Red |
| | | F | PE | Yellow/Green |
| | | B | Brake (polarity insensitive) | - |
| | | D | | |

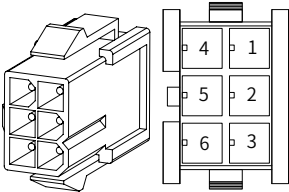

- ◆ The flange size refers to the width of the mounting flange.
- ◆ Power cable colors are subject to the actual cables. Cable colors mentioned in this user guide all refer to Inovance cables.

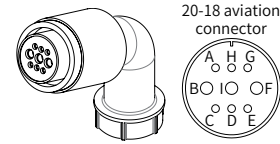
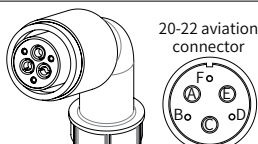
3.4.2 Connecting the Absolute Encoder

1 Connecting to IS620 series servo drives

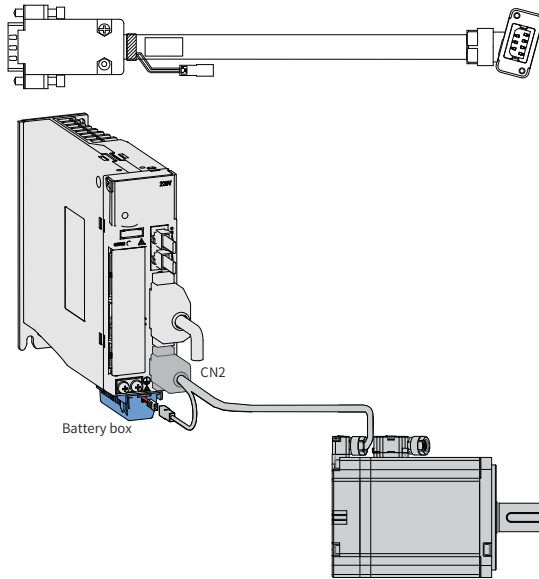

Figure 3-9 Connection between IS620 series servo drive and encoder

Table 3-15 Encoder cable connector of terminal-type servo motors

| Applicable Motor Flange Size | Outline Drawing of the Connector | | Terminal Pin Layout | | | |
|--|----------------------------------|--|---------------------|-------------|--------------|--------------|
| | | | Pin No. | Signal Name | Color | Type |
| Terminal-type motors: 40 (Z series) 60 (Z series) 80 (Z series) | Servo drive side | <p>Connected to CN2 of the servo drive</p> <p>Connector of the encoder lead wire</p> <p>DB9 Male</p> | 1 | PS+ | Blue | Twisted pair |
| | | | 2 | PS- | Purple | |
| | | | 7 | +5V | Red | Twisted pair |
| | | | 8 | 0V | Orange | |
| | Enclosure | PE | - | - | | |
| | Motor side | <p>SDC-07T (manufacture: JONHON)</p> | 1 | PS+ | Blue | Twisted pair |
| | | | 2 | PS- | Purple | |
| 3 | | | DC+ | Brown | Twisted pair | |
| 4 | | | DC- | Black | | |
| 5 | +5V | Red | Twisted pair | | | |
| 6 | 0V | Orange | | | | |
| 7 | PE | - | - | | | |

Table 3-16 Encoder cable connector for of lead wire-type servo motors

| Applicable Motor Flange Size | Outline Drawing of the Connector | | Terminal Pin Layout | | | |
|---|----------------------------------|--|---------------------|-------------|--------|--------------|
| | | | Pin No. | Signal Name | Color | Type |
| | Servo drive side |  <p>Connected to CN2 of the servo drive</p> <p>Connector of the encoder lead wire</p> <p>DB9 Male</p> | 1 | PS+ | Blue | Twisted pair |
| | | | 2 | PS- | Purple | |
| | | | 7 | +5V | Red | Twisted pair |
| | | | 8 | 0V | Orange | |
| | | | Enclosure | PE | - | - |
| Lead wire-type motors: 40 (Z-S series) 60 (Z-S series) 80 (Z-S series) | Motor side |  <p>Lead wire of the encoder</p> <p>Viewed from this side</p> <p>9-pin connector</p> <p>Recommendation: Plastic housing: AMP 172161-1; Terminal: AMP 770835-1</p> | 1 | Battery (+) | Brown | - |
| | | | 4 | Battery (-) | Black | |
| | | | 3 | PS+ | Blue | Twisted pair |
| | | | 6 | PS- | Purple | |
| | | | 9 | +5V | Red | - |
| | | | 8 | GND | Orange | |
| | | | 7 | Shield | | |

Table 3-17 Encoder cable connector of connector-type servo motors

| Applicable Motor Flange Size | Outline Drawing of the Connector | | Terminal Pin Layout | | | |
|---|----------------------------------|---|---------------------|-------------|--------|--------------|
| | | | Pin No. | Signal Name | Color | Type |
| Connector-type motors: 100 130 180 | Servo drive side |  <p>Connected to CN2 of the servo drive</p> <p>Connector of the encoder lead wire</p> <p>DB9 Male</p> | 1 | PS+ | Blue | Twisted pair |
| | | | 2 | PS- | Purple | |
| | | | 7 | +5V | Red | Twisted pair |
| | | | 8 | 0V | Orange | |
| | | | Enclosure | PE | - | - |
| | Motor side |  <p>Encoder connector</p> <p>Viewed from this side</p> <p>20-29 aviation connector</p> | A | PS+ | Blue | Twisted pair |
| | | | B | PS- | Purple | |
| | | | E | DC+ | Brown | Twisted pair |
| | | | F | DC- | Black | |
| | | | G | +5V | Red | Twisted pair |
| H | GND | Orange | | | | |
| J | Shield | - | - | | | |

2 Connecting to IS810N-INT Series Servo Drives

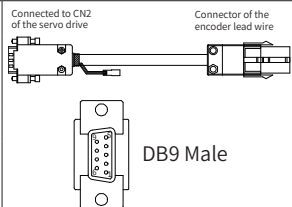
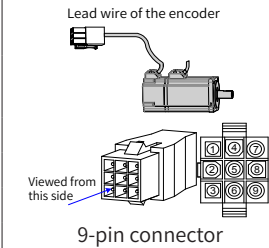
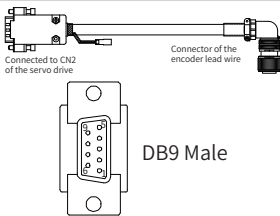
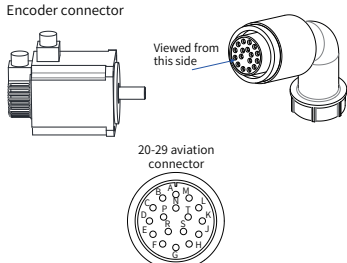
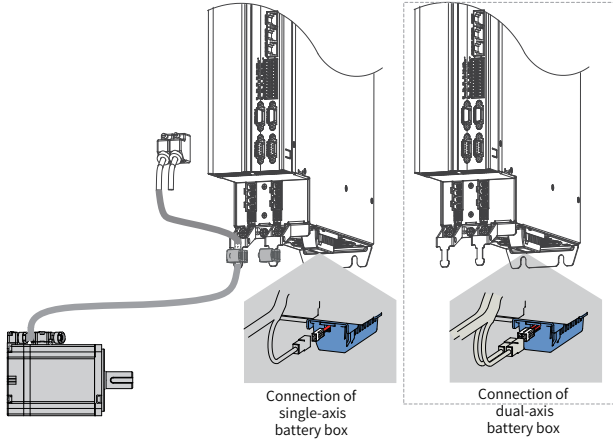

Figure 3-10 Connection between IS810N-INT series servo drive and encoder

Table 3-18 Encoder cable connector of terminal-type servo motors

| Applicable Motor Flange Size | Outline Drawing of the Connector | Terminal Pin Layout | | | |
|--|--|---------------------|-------------|--------|--------------|
| | | Pin No. | Signal Name | Color | Type |
| Terminal-type motors: 40 (Z series) 60 (Z series) 80 (Z series) | Servo drive side  DB9 Male | 1 | PS+ | Blue | Twisted pair |
| | | 2 | PS- | Purple | |
| | | 7 | +5V | Red | Twisted pair |
| | | 8 | 0V | Orange | |
| | Motor side  7-pin connector | Enclosure | PE | - | - |
| | | 1 | PS+ | Blue | Twisted pair |
| | | 2 | PS- | Purple | |
| | | 3 | DC+ | Brown | Twisted pair |
| | | 4 | DC- | Black | |
| | | 5 | +5V | Red | Twisted pair |
| 6 | 0V | Orange | | | |
| 7 | PE | - | - | | |

Table 3-19 Encoder cable connector of lead wire-type servo motors

| Applicable Motor Flange Size | Outline Drawing of the Connector | | Terminal Pin Layout | | | |
|---|----------------------------------|--|---------------------|-------------|--------------|--------------|
| | | | Pin No. | Signal Name | Color | Type |
| Lead wire-type motors: 40 (Z-S series) 60 (Z-S series) 80 (Z-S series) | Servo drive side |  <p>Connected to CN2 of the servo drive</p> <p>Connector of the encoder lead wire</p> <p>DB9 Male</p> | 1 | PS+ | Blue | Twisted pair |
| | | | 2 | PS- | Purple | |
| | | | 7 | +5V | Red | Twisted pair |
| | | | 8 | 0V | Orange | |
| | Enclosure | PE | - | - | | |
| | Motor side |  <p>Lead wire of the encoder</p> <p>Viewed from this side</p> <p>9-pin connector</p> <p>Recommendation: Plastic housing: AMP 172161-1; Terminal: AMP 770835-1</p> | 1 | Battery (+) | Brown | - |
| | | | 4 | Battery (-) | Black | |
| 3 | | | PS+ | Blue | Twisted pair | |
| 6 | | | PS- | Purple | | |
| 9 | | | +5V | Red | - | |
| 8 | | | GND | Orange | | |
| 7 | Shield | | | | | |

Table 3-20 Encoder cable connector of connector-type servo motors

| Applicable Motor Flange Size | Outline Drawing of the Connector | | Terminal Pin Layout | | | |
|---|----------------------------------|---|---------------------|-------------|--------|--------------|
| | | | Pin No. | Signal Name | Color | Type |
| Connector-type motors: 100 130 180 | Servo drive side |  <p>Connected to CN2 of the servo drive</p> <p>Connector of the encoder lead wire</p> <p>DB9 Male</p> | 1 | PS+ | Blue | Twisted pair |
| | | | 2 | PS- | Purple | |
| | | | 7 | +5V | Red | Twisted pair |
| | | | 8 | 0V | Orange | |
| | Enclosure | PE | - | - | | |
| | Motor side |  <p>Encoder connector</p> <p>Viewed from this side</p> <p>20-29 aviation connector</p> | A | PS+ | Yellow | Twisted pair |
| | | | B | PS- | Blue | |
| | | | E | DC+ | Brown | Twisted pair |
| | | | F | DC- | Black | |
| | | | G | +5V | Red | - |
| H | | | GND | Orange | | |
| J | Shield | - | | | | |

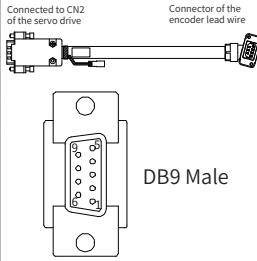
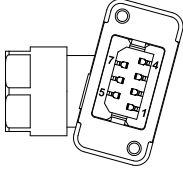
3 Connecting to IS810P series servo drive

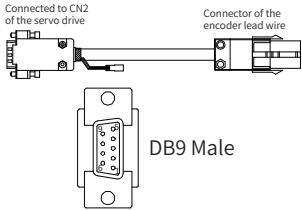
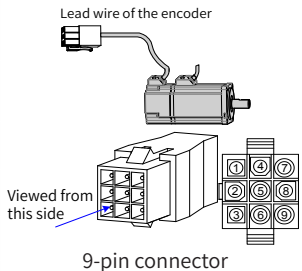
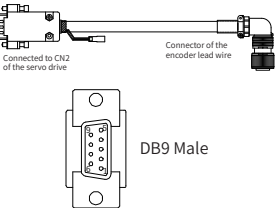
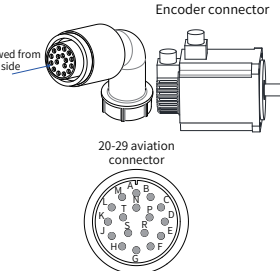
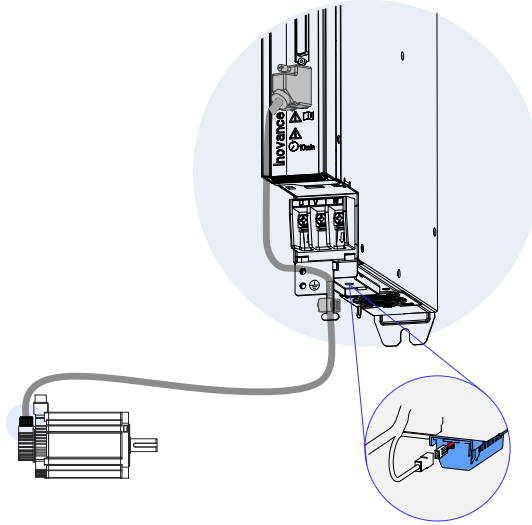

Figure 3-11 Connection between IS810P series servo drive and encoder

Table 3-21 Encoder cable connector of terminal-type servo motors

| Applicable Motor Flange Size | Outline Drawing of the Connector | | Terminal Pin Layout | | | |
|--|----------------------------------|--|---------------------|-------------|--------|--------------|
| | | | Pin No. | Signal Name | Color | Type |
| Terminal-type motors: 40 (Z series) 60 (Z series) 80 (Z series) | Servo drive side | <p>Connected to CN2 of the servo drive</p> <p>Connector of the encoder lead wire</p> <p>DB9 Male</p> | 1 | PS+ | Blue | Twisted pair |
| | | | 2 | PS- | Purple | |
| | | | 7 | +5V | Red | Twisted pair |
| | | | 8 | 0V | Orange | |
| | Motor side | <p>SDC-07T</p> | Enclosure | PE | - | - |
| | | | 1 | PS+ | Blue | Twisted pair |
| | | | 2 | PS- | Purple | |
| 3 | DC+ | Brown | Twisted pair | | | |
| 4 | DC- | Black | | | | |
| 5 | +5V | Red | Twisted pair | | | |
| 6 | 0V | Orange | | | | |
| 7 | PE | - | - | | | |

Table 3-22 Encoder cable connector of lead wire-type servo motors

| Applicable Motor Flange Size | Outline Drawing of the Connector | | Terminal Pin Layout | | | |
|---|----------------------------------|----|---------------------|-------------|--------------|--------------|
| | | | Pin No. | Signal Name | Color | Type |
| Lead wire-type motors: 40 (Z-S series) 60 (Z-S series) 80 (Z-S series) | Servo drive side | | 1 | PS+ | Blue | Twisted pair |
| | | | 2 | PS- | Purple | |
| | | | 7 | +5V | Red | Twisted pair |
| | | | 8 | 0V | Orange | |
| | Enclosure | PE | - | - | | |
| | Motor side | | 1 | Battery (+) | Brown | - |
| | | | 4 | Battery (-) | Black | |
| 3 | | | PS+ | Blue | Twisted pair | |
| 6 | | | PS- | Purple | | |
| 9 | | | +5V | Red | - | |
| 8 | | | GND | Orange | | |
| 7 | | | Shield | | | |

Table 3-23 Encoder cable connector (MIL-DTL-5015 series 3108E20-29S aviation connector)

| Applicable Motor Flange Size | Outline Drawing of the Connector | | Terminal Pin Layout | | | |
|---|----------------------------------|--------|---------------------|-------------|--------|--------------|
| | | | Pin No. | Signal Name | Color | Type |
| Connector-type motors: 100 130 180 | Servo drive side | | 1 | PS+ | Blue | Twisted pair |
| | | | 2 | PS- | Purple | |
| | | | 7 | +5V | Red | Twisted pair |
| | | | 8 | 0V | Orange | |
| | | | Enclosure | PE | - | - |
| | Motor side | | A | PS+ | Blue | Twisted pair |
| | | | B | PS- | Purple | |
| | | | E | DC+ | Brown | Twisted pair |
| | | | F | DC- | Black | |
| | | | G | +5V | Red | - |
| H | GND | Orange | | | | |
| J | Shield | - | | | | |

4 Connecting to SV820N series servo drives

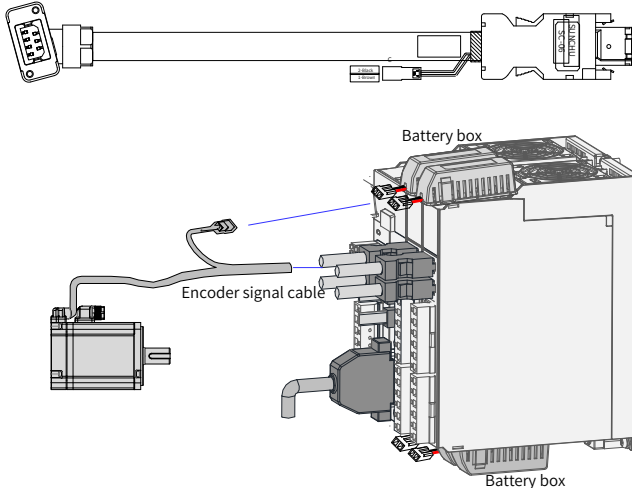

Figure 3-12 Connection between SV820N series servo drive and encoder

Table 3-24 Encoder cable connector of terminal-type servo motors

| Applicable Motor Flange Size | Outline Drawing of the Connector | Terminal Pin Layout | | | | |
|--|--|---------------------|--------------------------------------|--------|--------------|--------------|
| | | Pin No. | Signal Name | Color | Type | |
| Terminal-type motors: 40 (Z series) 60 (Z series) 80 (Z series) | <p>Connected to CN2 of the servo drive</p> <p>Connector of the encoder lead wire</p> <p>Servo drive side</p> <p>Joint face of 6-pin male</p> | 1 | +5V | Red | Twisted pair | |
| | | 2 | 0 V | Orange | | Twisted pair |
| | | 5 | PS+ | Blue | Twisted pair | |
| | | 6 | PS- | Purple | | Twisted pair |
| | | Enclosure | PE | - | - | |
| | | Motor side | <p>SDC-07T (manufacture: JONHON)</p> | 1 | PS+ | Blue |
| | 2 | | | PS- | Purple | Twisted pair |
| | 3 | | | DC+ | Brown | |
| | 4 | | | DC- | Black | Twisted pair |
| | 5 | | | +5V | Red | |
| 6 | 0V | | | Orange | Twisted pair | |
| 7 | PE | | | - | | - |

Table 3-25 Encoder cable connector of lead wire-type servo motors

| Applicable Motor Flange Size | Outline Drawing of the Connector | | Terminal Pin Layout | | | |
|---|----------------------------------|-------------|---------------------|---|--------------|--------------|
| | | | Pin No. | Signal Name | Color | Type |
| Lead wire-type motors: 40 (Z-S series) 60 (Z-S series) 80 (Z-S series) | Servo drive side | | 1 | +5V | Red | Twisted pair |
| | | | 2 | 0V | Orange | |
| | | | 5 | PS+ | Blue | Twisted pair |
| | | | 6 | PS- | Purple | |
| | | | Enclosure | PE | - | - |
| | | | Motor side | <p>Recommendation: Plastic housing: AMP 172161-1 Terminal: AMP 770835-1</p> | 1 | Battery (+) |
| | 4 | Battery (-) | | | Black | |
| 3 | PS+ | Blue | | | Twisted pair | |
| 6 | PS- | Purple | | | | |
| 9 | +5V | Red | | | Twisted pair | |
| 8 | GND | Orange | | | | |
| 7 | Shield | | | | | |

5 Connecting to SV660 Series Servo Drives

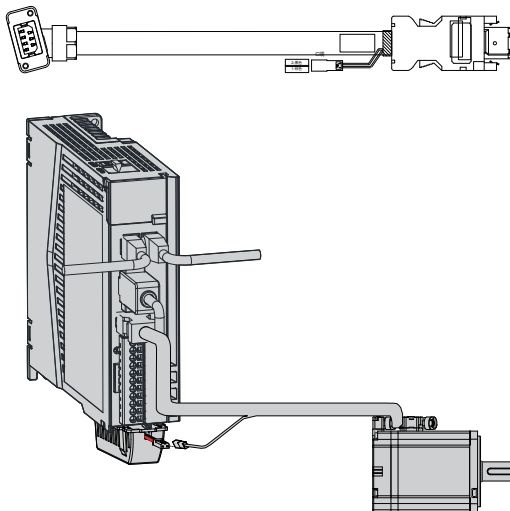

Figure 3-13 Connection between SV660 series servo drive and terminal-type motor encoder

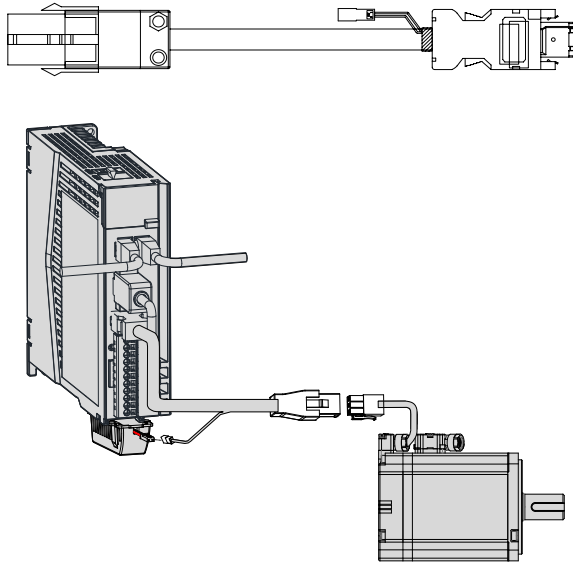

Figure 3-14 Connection between SV660 series servo drive and lead wire-type motor encoder

Table 3-26 Encoder cable connector of terminal-type servo motors

| Applicable Motor Flange Size | Outline Drawing of the Connector | Terminal Pin Layout | | | | |
|--|---|---------------------|--------------------------------------|--------|--------------|--------------|
| | | Pin No. | Signal Name | Color | Type | |
| Terminal-type motors: 40 (Z series) 60 (Z series) 80 (Z series) | <p>Servo drive side</p> <p>Joint face of 6-pin male</p> | 1 | +5V | Red | Twisted pair | |
| | | 2 | 0V | Orange | | |
| | | 5 | PS+ | Blue | Twisted pair | |
| | | 6 | PS- | Purple | | |
| | | Enclosure | PE | - | - | |
| | | Motor side | <p>SDC-07T (manufacture: JONHON)</p> | 1 | PS+ | Blue |
| | 2 | | | PS- | Purple | |
| | 3 | | | DC+ | Brown | Twisted pair |
| | 4 | | | DC- | Black | |
| | 5 | | | +5V | Red | Twisted pair |
| 6 | 0V | | | Orange | | |
| 7 | PE | | | - | - | |

Table 3-27 Encoder cable connector of lead wire-type servo motors



| Applicable Motor Flange Size | Outline Drawing of the Connector | | Terminal Pin Layout | | | |
|---|----------------------------------|---|---------------------|-------------|--------|--------------|
| | | | Pin No. | Signal Name | Color | Type |
| Lead wire-type motors: 40 (Z-S series) 60 (Z-S series) 80 (Z-S series) | Servo drive side | <p>Joint face of 6-pin male</p> | 1 | +5V | Red | Twisted pair |
| | | | 2 | 0V | Orange | |
| | | | 5 | PS+ | Blue | Twisted pair |
| | | | 6 | PS- | Purple | |
| | | | Enclosure | PE | - | - |
| | Motor side | <p>9-pin connector Recommendation: Plastic housing: AMP 172161-1 Terminal: AMP 770835-1</p> | 1 | Battery (+) | Brown | Twisted pair |
| | | | 4 | Battery (-) | Black | |
| | | | 3 | PS+ | Blue | Twisted pair |
| | | | 6 | PS- | Purple | |
| | | | 9 | +5V | Red | Twisted pair |
| 8 | | | GND | Orange | | |
| 7 | Shield | | | | | |

Table 3-28 Encoder cable connector (MIL-DTL-5015 series 3108E20-29S aviation connector)

| Applicable Motor Flange Size | Outline Drawing of the Connector | | Terminal Pin Layout | | | |
|--|----------------------------------|---------------------------------|---------------------|-------------|--------------|--------------|
| | | | Pin No. | Signal Name | Color | Type |
| Connector-type motors 100 130 180 | Servo drive side | <p>Joint face of 6-pin male</p> | A | PS+ | Yellow | Twisted pair |
| | | | B | PS- | Yellow/Black | |
| | | | E | Battery (+) | Blue | - |
| | | | F | Battery (-) | Blue/Black | |
| | | | G | +5V | Red | - |
| | H | GND | Black | | | |
| | J | Shield | | | | |
| | Motor side | <p>20-29 aviation connector</p> | A | PS+ | Yellow | Twisted pair |
| | | | B | PS- | Yellow/Black | |
| | | | E | Battery (+) | Blue | - |
| F | | | Battery (-) | Blue/Black | | |
| G | | | +5V | Red | - | |
| H | GND | Black | | | | |
| J | Shield | | | | | |

3.4.3 Requirements for connecting connectors

1 Power connector

| | |
|--|---|
|  WARNING | |
|  | Screw-down is allowed only when the rubber gasket of the plug is in place with both long edges kept flat. |

Align pins 5 and 6 to corresponding holes and insert them into the holes. Do not insert pins 5 and 6 by force. After insertion, screw down with a tightening torque of $0.1 \text{ N} \cdot \text{m}$ to $0.15 \text{ N} \cdot \text{m}$.

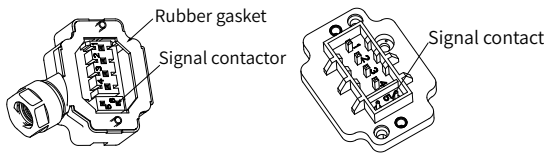

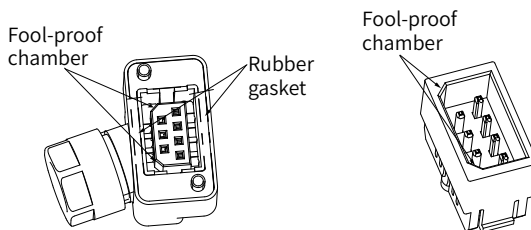

Figure 3-15 Power connector

2 Encoder connector

| | |
|--|---|
|  WARNING | |
|  | Screw-down is allowed only when the rubber gasket of the plug is in place with both long edges locked into the enclosure slot flatly. |

Plugs and sockets are designed with fool-proof chamfers (as shown below). Align the fool-proof chamfer before insertion (forcible insertion is not allowed). After insertion, screw down the plug screws with a tightening torque of $0.1 \text{ N} \cdot \text{m}$ to $0.15 \text{ N} \cdot \text{m}$.



Note that the two long edges of the rubber gasket must be flatly locked into the slot of the enclosure.

Figure 3-16 Encoder connector



- ◆ The assembly direction of the plug insulator is subject to the actual direction.
- ◆ Do not energize an electrical connector connected loosely. Plug-in or Plug-out is not allowed when the power supply is switched on.
- ◆ The mating life of the electrical connector is 50 cycles. Ensure the joint face of the socket and plug is clean and free from greasy dirt in the whole service life. Handle with enough care during use to prevent injuries.
- ◆ Check whether the socket and plug are free from condensation and greasy dirt each time before mating.
- ◆ When the connector is idled with its socket and plug separated, take proper measures to prevent intrusion of dust and liquid.

Appendix A Motor Selection Examples

A.1 Examples for Position Control

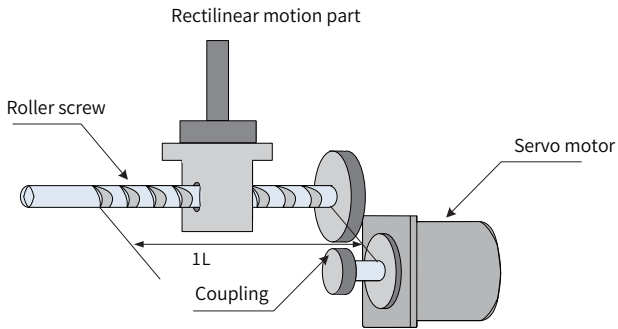

Load speed (V_L): 15 m/min

Mass of the rectilinear motion part (m): 80 kg

Length of the roller screw (l_B): 0.8 m

Diameter of the roller screw (d_B): 0.8 m

Pitch of the roller screw (P_B): 0.005 m

Mass of the coupling (m_c): 0.3 kg

Outer diameter of the coupling (d_c): 0.03 m

Times of feeding (n): 40 times/min

Length of feeding (L): 0.25 m

Time of feeding (t_m): < 1.2s

Electrical stop precision (δ): ± 0.01 mm

Friction coefficient (μ): 0.2

Mechanical efficiency (η): 0.9 (90%)

1 Speed diagram

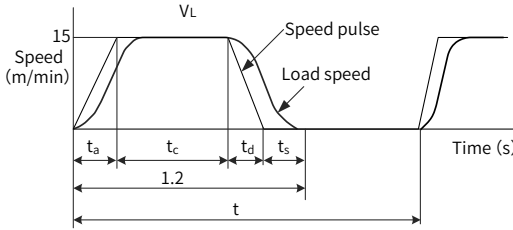

$$t = \frac{60}{n} = \frac{60}{40} = 1.5(\text{s})$$

$$T_a = t_d, t_s = 0.1(\text{s})$$

$$T_a = t_m - t_s - \frac{60L}{V_L} = 1.2 - 0.1 - \frac{60 \times 0.25}{15} = 0.1(\text{s})$$

$$t_c = 1.2 - 0.1 - 0.1 \times 2 = 0.9(\text{s})$$

2 Rotational speed

- Rotational speed of the load shaft

$$n_l = \frac{V_L}{P_B} = \frac{15}{0.005} = 3000(\text{RPM})$$

- Rotational speed of the motor shaft

As the coupling is connected directly to the motor, the reduction ratio (1/R) is 1:1.

$$n_M = n_L; R = 3000 \times 1 = 3000(\text{RPM})$$

3 Load torque

$$T_L = \frac{V_L}{P_B} = \frac{9.8 \mu \cdot m \cdot P_B}{2\pi R \cdot \eta} = \frac{9.8 \times 0.2 \times 80 \times 0.005}{2\pi \times 1 \times 0.9} = 0.139(\text{N} \cdot \text{m})$$

4 Load moment of inertia

- Rectilinear motion part

$$J_M = m \left(\frac{P_B}{2\pi R} \right)^2 = 80 \times \left(\frac{0.005}{2\pi \times 1} \right)^2 = 0.507 \times 10^{-4}(\text{kg} \cdot \text{m}^2)$$

- Roller screw

$$J_B = \frac{\pi}{32} P \cdot L_B \cdot d_B^4 = \frac{\pi}{32} \times 7.87 \times 10^3 \times 0.8 \times (0.016)^4 = 0.405 \times 10^{-4}(\text{kg} \cdot \text{m}^2)$$

- Coupling

$$J_C = \frac{1}{8} m_C \cdot d_C^4 = \frac{1}{8} \times 0.3 \times (0.03)^4 = 0.338 \times 10^{-4}(\text{kg} \cdot \text{m}^2)$$

5 Load moving power

$$P_O = \frac{2\pi n_M \cdot T_L}{60} = \frac{2\pi \times 3000 \times 0.139}{60} = 43.7(\text{W})$$

6 Load acceleration power

$$P_a = \left(\frac{2\pi}{60} n_m \right)^2 \frac{J_L}{t_a} = \left(\frac{2\pi}{60} \times 3000 \right)^2 \times \frac{1.25 \times 10^{-4}}{0.1} = 123.4(\text{W})$$

7 Temporary settings of the servo motor

■ Selection condition

$T_L \leq$ Rated torque of the motor

$P_a + P_o = (1 \text{ to } 2) \times$ Rated output of the motor

$n_M \leq$ Rated speed of the motor

$J_L \leq$ Allowable load moment of inertia of the servo unit

Perform the following temporary selections according to preceding conditions:

Servo motor: MS1H1-20B30CB-A331Z

Servo drive: SV660PS2R8I

■ Technical data of the servo motor and servo drive

Rated output: 200 (W)

Rated speed: 3000 (min^{-1})

Rated torque: 0.637 ($\text{N} \cdot \text{m}$)

Maximum transient torque: 1.91 ($\text{N} \cdot \text{m}$)

Rotor moment of inertia: 0.158×10^{-4} ($\text{kg} \cdot \text{m}^2$)

Allowable load moment of inertia: 3.69×10^{-4} ($\text{kg} \cdot \text{m}^2$)

Number of encoder pulses: 8388608 (PPR)

■ Confirmation of the servo motor selected temporarily

Confirm the startup torque required

$$T_p = \frac{2\pi \text{nm}(J_M + J_L)}{60t_a} + T_L = \frac{2\pi \times 3000 \times (0.209 + 1.25) \times 10^{-4}}{60 \times 0.1} + 0.139$$

$$= 0.597 (\text{N} \cdot \text{m}) < \text{Max. transient torque... (available for use)}$$

Confirm the braking torque required

$$T_s = \frac{2\pi \text{nm}(J_M + J_L)}{60t_a} - T_L = \frac{2\pi \times 3000 \times (0.209 + 1.25) \times 10^{-4}}{60 \times 0.1} - 0.139$$

$$= 0.319 (\text{N} \cdot \text{m}) < \text{Max. transient torque... (available for use)}$$

Confirm the effective torque value

$$T_{\text{rms}} = \sqrt{\frac{T_p^2 \cdot t_a + T_L^2 \cdot t_c + T_s^2 \cdot t_d}{t}} = \sqrt{\frac{(0.597)^2 \times 0.1 + (0.139)^2 \times 0.9 + (0.139)^2 \times 0.1}{1.5}}$$

$$= 0.205 (\text{N} \cdot \text{m}) < \text{Rated torque... (available for use)}$$

Capacities of the servo motor and servo drive selected temporarily based on preceding steps are available for use. Analysis on position control is as follows.

8 Electronic gear ratio (B/A)

As the electrical stop precision (δ) is ± 0.01 mm, set the position detection unit (ΔL) to 0.01 mm/pulse.

$$\frac{P_B}{\Delta L} \times \left(\frac{B}{A}\right) = \frac{5}{0.01} \times \left(\frac{B}{A}\right) = 1048576 \times 4$$

$$k = \left(\frac{B}{A}\right) = \frac{1048576 \times 4}{500}$$

9 Reference pulse frequency

$$v_s = \frac{1000 \times 4V_L}{60 \times \Delta l} = \frac{1000 \times 15}{60 \times 0.01} = 25000 \text{ (pps)}$$

10 Offset counter droop pulse

- Set the position loop gain (K_p) to 30 (l/s).

$$\epsilon = \frac{v_s}{K_p} = \frac{25000}{30} = 833 \text{ (pulse)}$$

- Electrical stop precision

$$\pm \Delta \epsilon = \pm \frac{\epsilon}{(\text{Servo drive control range}) \times \frac{nM}{nR}} = \pm \frac{833}{5000 \times \frac{3000}{3000}} = \pm 0.17 < \pm 1 \text{ (pulse)} = \pm 0.01 \text{ (mm/pulse)}$$

By observing preceding steps, the servo motor and servo drive selected temporarily for position control are available for use.

A.2 Examples for Speed Control

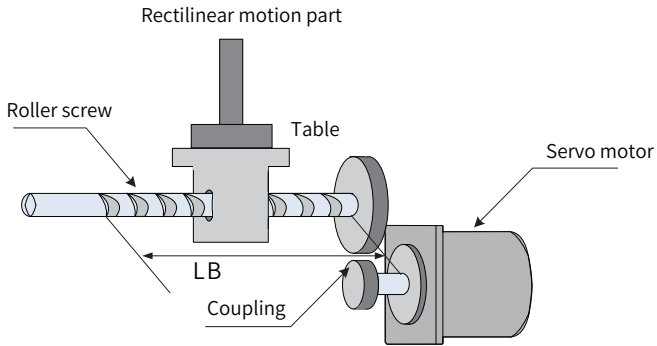

Load speed (V_L): 15 m/min

Mass of the rectilinear motion part (m): 80 kg

Length of the roller screw (LB): 1.4 m

Diameter of the roller screw (d_B): 0.04 m

Pitch of the roller screw (PB): 0.01 m

Mass of the coupling (m_c): 1 kg

Outer diameter of the coupling (d_c): 0.06 m

Times of feeding (n): 40 times/min

Length of feeding (L): 0.275 m

Time of feeding (t_m): < 1.2s

Friction coefficient (μ): 0.2

Mechanical efficiency (η): 0.9 (90%)

1 Speed diagram

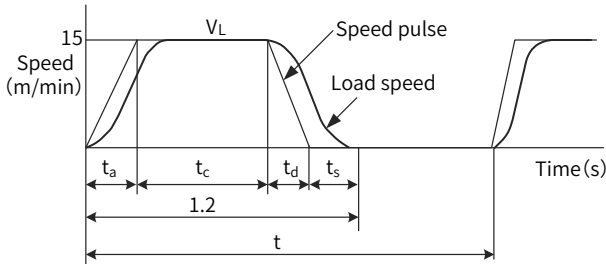

$$t = \frac{60}{n} = \frac{60}{40} = 1.5 \text{ (s)}$$

Set t_a to the same value as t_d .

$$t_a = t_m - t_s - \frac{60L}{V_L} = 1.2 - 0.1 - \frac{60 \times 0.25}{15} = 0.1 \text{ (s)}$$

$$t_c = 1.2 - 0.1 \times 2 = 1.0 \text{ (s)}$$

2 Rotational speed

- Rotational speed of the load shaft

$$n_l = t_m \cdot \frac{V_L}{P_B} = \frac{15}{0.01} = 1500 \text{ (min}^{-1}\text{)}$$

- Rotational speed of the motor shaft

As the coupling is connected directly to the motor, the reduction ratio (1/R) is 1:1.

$$n_M = n_L; R = 1500 \times 1 = 1500 \text{ (min}^{-1}\text{)}$$

3 Load torque

$$T_L = \frac{V_L}{P_B} = \frac{9.8 \mu \cdot m \cdot P_B}{2\pi R \cdot \eta} = \frac{9.8 \times 0.2 \times 500 \times 0.01}{2\pi \times 1 \times 0.9} = 1.73 \text{ (N} \cdot \text{m)}$$

4 Load moment of inertia

- Rectilinear motion part

$$J_{LI} = m \left(\frac{P_B}{2\pi R} \right)^2 = 500 \times \left(\frac{0.01}{2\pi \times 1} \right)^2 = 12.7 \times 10^{-4} \text{ (kg} \cdot \text{m}^2\text{)}$$

- Roller screw

$$J_B = \frac{\pi}{32} P \cdot L_B \cdot dB^4 = \frac{\pi}{32} \times 7.87 \times 10^3 \times 1.4 \times (0.04)^4 = 27.7 \times 10^{-4} \text{ (kg} \cdot \text{m}^2\text{)}$$

■ Coupling

$$J_c = \frac{1}{8} m c \cdot d c^4 = \frac{1}{8} \times 1 \times (0.06)^2 = 4.5 \times 10^{-4} (\text{kg} \cdot \text{m}^2)$$

5 Load moving power

$$P_o = \frac{2\pi nM \cdot T_L}{60} = \frac{2\pi \times 1500 \times 1.73}{60} = 272(\text{W})$$

6 Load acceleration power

$$P_a = \left(\frac{2\pi}{60} \text{nm} \right)^2 \frac{J_L}{t_a} = \left(\frac{2\pi}{60} \times 1500 \right)^2 \times \frac{44.9 \times 10^{-4}}{0.1} = 1108(\text{W})$$

7 Temporary settings of the servo motor

■ Selection condition

$T_L \leq$ Rated torque of the motor

$P_a + P_o = (1 \text{ to } 2) \times$ Rated output of the motor

$nM \leq$ Rated torque of the motor

$J_L \leq$ Allowable load moment of inertia of the servo unit

Perform the following temporary selections according to preceding conditions:

Servo motor: MS1H3-85C15CD-A331Z

Servo drive: SV660PT5R4I

■ Technical data of the servo motor and servo drive

Rated output: 850 (W)

Rated speed: 1500 (min^{-1})

Rated torque: 5.39 ($\text{N} \cdot \text{m}$)

Maximum transient torque: 13.8 ($\text{N} \cdot \text{m}$)

Rotor moment of inertia: 13.0×10^{-4} ($\text{kg} \cdot \text{m}^2$)

Allowable load moment of inertia: 69.58×10^{-4} ($\text{kg} \cdot \text{m}^2$)

8 Confirmation of the servo motor selected temporarily

■ Confirm the startup torque required

$$\begin{aligned} T_p &= \frac{2\pi nM(J_M + J_L)}{60 t_a} + T_L = \frac{2\pi \times 1500 \times (13.9 + 44.9) \times 10^{-4}}{60 \times 0.1} + 1.73 \\ &= 11(\text{N} \cdot \text{m}) < \text{Max. transient torque... (available for use)} \end{aligned}$$

- Confirm the braking torque required

$$T_s = \frac{2\pi n m (J_M + J_L)}{60 t_a} - T_L = \frac{2\pi \times 1500 \times (13.9 + 44.9) \times 10^{-4}}{60 \times 0.1} - 1.73$$

$$= 7.5 (\text{N} \cdot \text{m}) < \text{Max. transient torque... (available for use)}$$

- Confirm the effective torque value

$$T_{rms} = \sqrt{\frac{T_p^2 \cdot t_a + T_L^2 \cdot t_c + T_s^2 \cdot t_d}{t}} = \sqrt{\frac{(11)^2 \times 0.1 + (1.73)^2 \times 0.1 + (7.5)^2 \times 0.1}{1.5}}$$

$$= 3.72 (\text{N} \cdot \text{m}) < \text{Rated torque... (available for use)}$$

9 Selection result

By observing preceding steps, the servo motor and servo drive selected temporarily for speed control are available for use. The torque diagram is as follows.

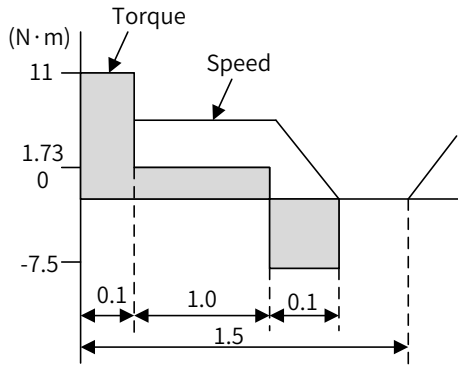

Appendix B: Disassembly of the Flat Key and Oil Seal

|  WARNING | |
|---|--|
|  | <ul style="list-style-type: none"> ◆ Observe all the requirements presented in this chapter. Failure to comply may result in device fault or damage. ◆ Violent disassembly is not allowed. Take enough care during disassembly to prevent physical injuries. |

■ Removing the flat key

Standard MS1 series motors in flange sizes 60, 80, and 130 adopt C-type flat keys equipped with disassembly hole. To remove the flat key, select a proper disassembly bolt (inner hexagon bolt recommended) and an Allen wrench to screw down the bolt clockwise until A-A end of the flat key is completely detached from the keyway, as shown below.

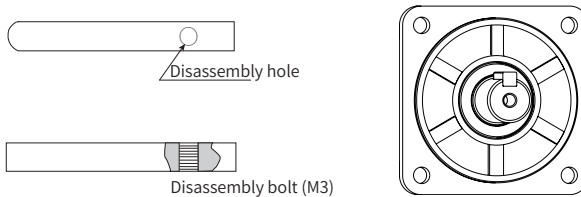

| Specifications and Dimensions | | |
|-------------------------------|---------------------------|---|
| Specification of MS1 Motor | Dimensions of Flat Key | Specifications of Disassembly Bolt (Inner Hexagon Bolt) |
| Flange size 40 | A-type flat key—A3x3x14 | Disassembly hole not available |
| Flange size 60 | C-type flat key—C5x5x16.5 | M3x10 and above |
| Flange size 80 | C-type flat key—C6x6x25 | M3x15 and above |
| Flange size 100 | C-type flat key—C8x7x35 | M3x20 and above |
| Flange size 130 | C-type flat key—C8x7x35 | M3x20 and above |
| Flange size 180 | C-type flat key—C10x8x64 | M3x20 and above |

■ Removing the oil seal

Tools needed: a pair of needle-nose pliers, a pair of slip-proof gloves, and a piece of cotton cloth

Operating steps:

- 1) Step1: Put the cotton cloth on the supporting point B to avoid the end cover from being scratched during disassembly.
- 2) Step 2: Secure the motor and use the needle-nose pliers to hold point A of the oil seal lip.

- 3) Step 3: Pry the oil seal out gradually based on the supporting point B.

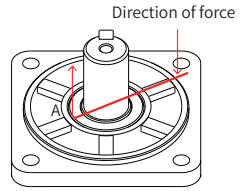
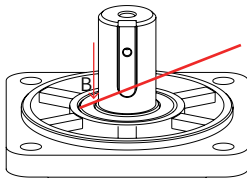

(Point B acts on the shaft extension stairs) (Point A acts on the oil seal lip)

Shenzhen Inovance Technology Co., Ltd.

Add.: Building E, Hongwei Industry Park, Liuxian Road, Baocheng No. 70 Zone, Bao'an District, Shenzhen

Tel: +86-755-2979 9595

Fax: +86-755-2961 9897

<http://www.inovance.com>

Suzhou Inovance Technology Co., Ltd.

Add.: No. 16 Youxiang Road, Yuexi Town, Wuzhong District, Suzhou 215104, P.R. China

Tel: +86-512-6637 6666

Fax: +86-512-6285 6720

<http://www.inovance.com>



19010786C02

Copyright © Shenzhen Inovance Technology Co., Ltd.