

TONGLI
股票代码 301255

SJ系列减速机选型样本



10
二〇二四年
(总第十版)

入选《机械设计手册》选型标准
(化工工业出版社/机械工业出版社)

Listed in 《Handbook of mechanical design》
as guideness of gearbox selection

STANDARD
PRODUCTS

标准产品



I TR系列斜齿齿轮硬齿面减速机
TR series Rigid Tooth Flank
Helical Gear Reducer

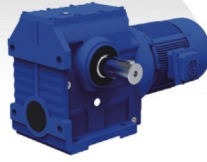

I TS系列斜齿-蜗轮蜗杆减速机
TS series Helical-worm
Gear Reducer



I TF系列平行轴斜齿齿轮减速机
TF series Parallel Shaft
Helical Gear Reducer



I TK系列螺旋锥齿减速机
TK series Helical-bevel
Gear Reducer

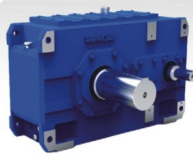

I TH系列硬齿面齿轮减速机
TH series Rigid Tooth Flank
Gearbox

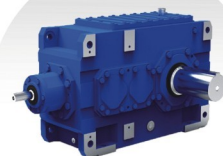

I TB系列硬齿面齿轮减速机
TB series Rigid Tooth Flank
Gearbox



I SJ系列涡轮丝杆升降机
SJ series Worm Screw
elevators



I Z系列螺旋锥齿减速机
Z series Spiral Bevel
Gear Reducer



I TP系列行星齿轮减速机
TP series Planetary
Gear Units

通力产品模块化组合体系

TONGLI Modulation Combination System

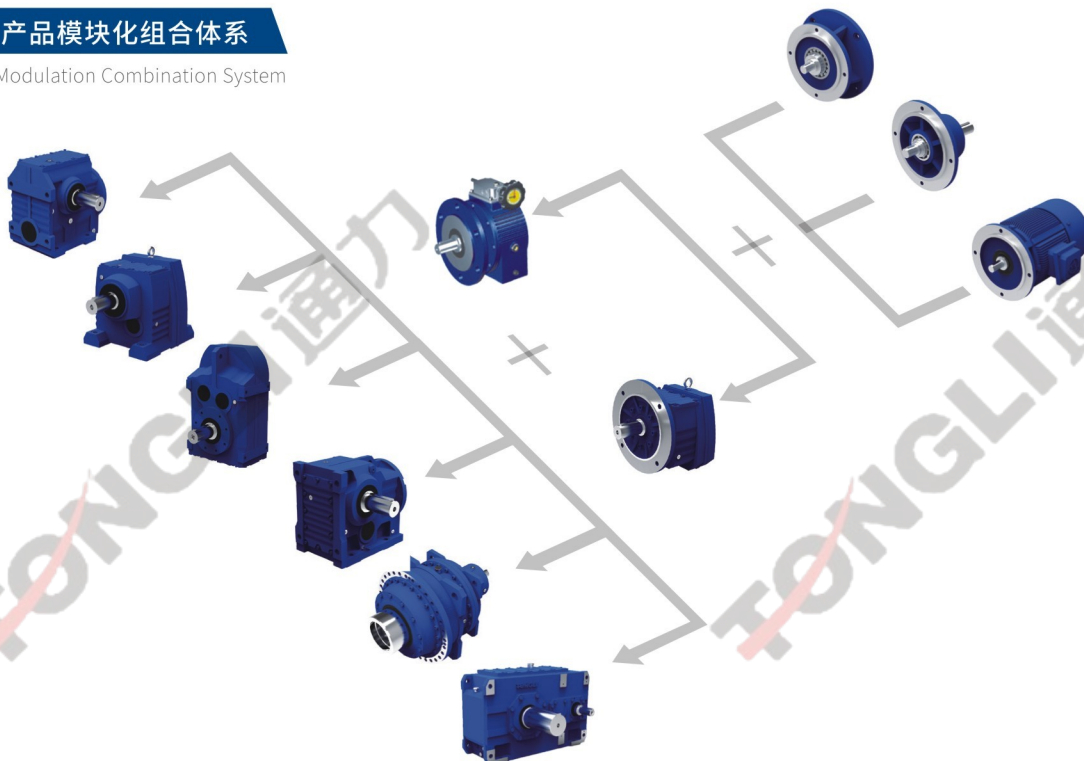

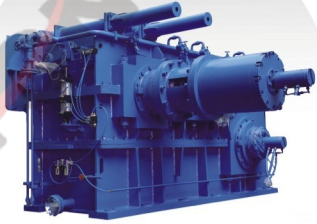

| 粗轧卷取机用减速机
Uncoiler Specialized
Gearbox



| 粗轧机用主减速机
Rolling Mill
Specialized Gearbox

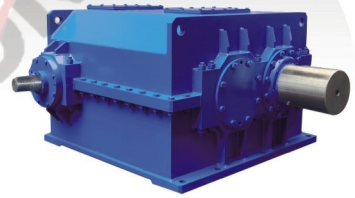

| 刮板输送机用减速机
Scraper Conveyor
Specialized Gearbox

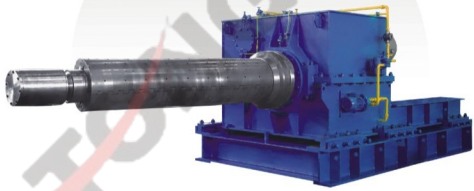

| 开收卷机用减速机
Uncoiler
Specialized Gearbox

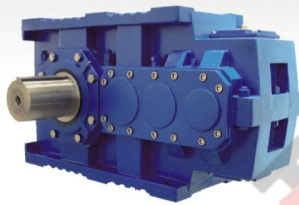

| 棕榈油专用减速机
Palm Oil Specialized
Gearbox

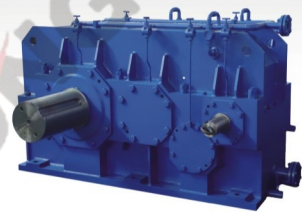

| 干燥窑用减速机
Dry Kiln Specialized
Gearbox



| 精轧卷取机用减速机
Precision Uncoiler
Specialized Gearbox

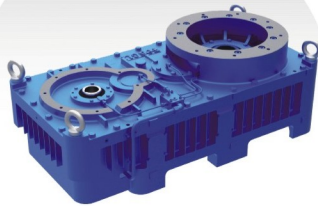

| 颗粒机专用减速机
Granulator Specialized
Gearbox

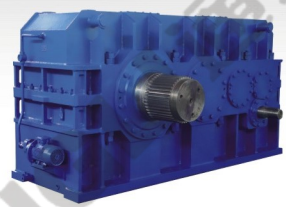

| 启闭机用减速机
Hoist Specialized
Gearbox

ENTERPRISE
PROFILE

公司简介

浙江通力传动科技股份有限公司创建于2008年，是一家专业从事减速机研发生产、销售及服务的国家高新技术企业、国家级绿色工厂、国家专精特新“小巨人”企业，下辖通用减速机、工业齿轮箱两大生产基地。公司于2022年12月27日在深交所创业板上市（股票简称:通力科技，股票代码:301255），经过十余年的稳健发展和技术积累，公司现已成为中国减速机行业的知名企业之一，在技术、装备、产品性能等方面均处于国内先进水平。近年来，通力作为起草单位参与制定了4项减速机国家标准与行业标准;拥有多项核心技术专利，自主研发多个系列减速机(齿轮箱)产品，其中部分产品被列为国家重点新产品和国家火炬计划项目。

通力主导产品通用减速机、工业齿轮箱广泛应用于冶金、化工、环保、能源、制药、起重、输送、建材、粮油等国民经济的支柱产业领域。先后为中国一重、中国二重、中国中冶、中粮集团、青山控股、齐鲁制药、宁德时代、中央电视台春晚舞台、北京冬奥会、杭州亚运会等国内大型工业企业及国家重点工程项目提供高性能的配套减速机，并出口东南亚、南美、中东等国家和地区，获得国内外众多客户的首肯和赞许。

Zhejiang TONGLI Transmission Technology Co., LTD. established in 2008 and is a National High-tech Enterprise and National Specialized New Little Giant Enterprise which engaged in gearbox R & D, manufacturing, sales and service. At present, TONGLI has two production bases for general reducer and industrial gearbox. On 27th Dec. 2022, TONGLI was floated on GEM of Shenzhen Stock Exchange (Stock for short: TONGLI Tech., Stock code: 301255). After more than 10 years of steady development and technical accumulation, TONGLI has become one of the well-known enterprises in China reducer industry, and in the domestic advanced level in technology, equipment, product performance and other aspects. In recent years, as a drafting unit, TONGLI has participated in the formulation of four national and industry standards for reducer, owns a number of core technology patents and independently developed a number of series of reducer and gearbox. Some products have been listed as national key new products and national torch plan projects. TONGLI's leading products are widely used in Metallurgy, Chemical, Environmental protection, Energy, Pharmaceutical, Hoist, Transportation, Building materials, Grain and oil and other pillar industries of the national economy. At the same time, TONGLI successively provide high performance matching gearbox for CFHI, CNEG, MCC Group, COFCO, Tsingshan Holding, QILU Pharmaceutical, CATL, the CCTV Spring Festival Gala stage, Beijing Winter Olympics and other large domestic industrial enterprises and national key projects. TONGLI gearbox exported to Southeast Asia, South America, the Middle East and other countries and regions, and obtained many approvals and praises from home and abroad customers.



通力产品选型信息：

客户：			浙江通力传动科技股份有限公司		
联系人		电话		销售员	
E-MAIL		传真		电 话	
地址			时 间	年 月 日	
工作机	设备名称：				
额定功率：	kw	工作扭矩：	N.m	转速：	r/min
日工作制：(1) ≤ 0.5h (2) 0.5-10h (3) > 10h					
环境温度：	°C	海拔高度：	m	起动扭矩：	N.m
起动频率：				次/h	
冲击载荷：(1) 强烈冲击 (2) 中等冲击 (3) 轻微冲击 (4) 没有冲击				冲击载荷频率：	
安装空间 (1) 狭小空间 风速 ≤ 0.5m/s (2) 大厅或大车间 风速 ≥ 1.4 m/s (3) 室外 风速 ≥ 4 m/s			使用场合：(1) 普通 (2) 腐蚀 (3) 盐雾 (4) 粉尘		
原动机	原动机名称		原动机型号		
原动机描述 (如功率、转速、制动等)					
电机型号：			类别：(1) 普通电机 (2) 辊道电机 (3) 其他电机		
功能特性 (可多选)：(1) 制动 (2) 防爆 (3) 变频调速 (4) 其他					
参数及性能		电机功率：	KW	电机极数	基准频率：
					Hz
额定电压：	V	额定电流：	A	防护等级：	绝缘等级：
其他： 注：用户自配电机时请提供电动机的联接尺寸图					
减速机要求	要求的产品系列：		安装型式 (根据样本选取)		
输出轴方式：(1) 单向实心轴 (2) 双向实心轴 (3) 平键空心轴 (4) 锁紧盘空心轴 (5) 内花键空心轴 (6) 外花键实心轴					
原动机与减速机的联接方式：(1) 直联 (无联接法兰) (2) 直联 (有联接法兰) (3) 联轴器 (4) 皮带轮 (5) 链轮					
工作机与减速机的联接方式：(1) 直联 (2) 齿轮 (3) 联轴器 (4) 皮带轮 (5) 链轮					
输出轴与输入轴之间的结构形式：(1) 平行轴 (2) 直交轴 (3) 同轴					
电机接线盒位置 (根据样本选取)：(1) I (0°) (2) II (270°) (3) III (180°) (4) IV (90°) (5) V (0°) (6) VI (270°) (7) VII (180°) (8) VIII (90°)					
附件及其他要求：					
输入轴、输出轴法兰及锁紧盘方向：					
输入轴旋转方向①：				输出轴旋转方向①：	
输入轴外部径向力及作用点：					
输出轴外部径向力及作用点：					
输入轴外部轴向力及方向：			输出轴外部轴向力及方向：		
减速机的其他特殊要求：					
预选型号：					

①TB、TP..L、TP..K型减速机必须填写，TK系列只需填输出轴旋向，其他可不填。

②本选型信息表适用于TH、TB、TP、TR、TK、TF、TS系列减速机。

注：请在数字下面打√

轴端螺纹孔，配合公差，平键和键槽

Centre Holes in Shaft Ends, Fit tolerance and Parallel Key and Keyway

轴端螺纹孔		Centre holes in shaft end								
		mm								
轴径 Φd Diameter	$\geq 16\sim 21$	$>21\sim 24$	$>24\sim 30$	$>30\sim 38$	$>38\sim 50$	$>50\sim 85$	$>85\sim 130$	$>130\sim 225$	$>225\sim 320$	$>320\sim 500$
螺孔尺寸 Screw	M6×12	M8×16	M10×20	M12×20	M16×30	M20×35	M24×40	M30×50	M36×60	M42×70

配合公差 Selection of ISO Fits		
轴径 Shaft d/mm	轴径公差 Shaft tolerance	孔公差 Bore tolerance
≤ 25	k6	H7
>25	m6	H7
>100	n6	H7

平键和键槽		Parallel key and keyway				
		mm				
平键紧固采用无锥度联接。 平键和键槽根据 GB/T 1095-1979 标准确定 Drive type fastening without taper action. Parallel key and keyway acc. to GB/T 1095-1979		直径 Diameter d	宽度 Width b	高度 Height h	轴键槽深度 Depth of keyway in shaft t ₁	轮毂键槽深度 Depth of keyway in hub d+t ₂
		$>8-10$	3	3	1.8	d+1.4
$>10-12$	4	4	2.5	d+1.8		
$>12-17$	5	5	3	d+2.3		
$>17-22$	6	6	3.5	d+2.8		
$>22-30$	8	7	4	d+3.3		
$>30-38$	10	8	5	d+3.3		
$>38-44$	12	8	5	d+3.3		
$>44-50$	14	9	5.5	d+3.8		
$>50-58$	16	10	6	d+4.3		
$>58-65$	18	11	7	d+4.4		
$>65-75$	20	12	7.5	d+4.9		
$>75-85$	22	14	9	d+5.4		
$>85-95$	25	14	9	d+5.4		
$>95-110$	28	16	10	d+6.4		
$>110-130$	32	18	11	d+7.4		
$>130-150$	36	20	12	d+8.4		
$>150-170$	40	22	13	d+9.4		
$>170-200$	45	25	15	d+10.4		
$>200-230$	50	28	17	d+11.4		
$>230-260$	56	32	20	d+12.4		
$>260-290$	63	32	20	d+12.4		
$>290-330$	70	36	22	d+14.4		
$>330-380$	80	40	25	d+15.4		
$>380-440$	90	45	28	d+17.4		
$>440-500$	100	50	31	d+19.4		

注：配合公差仅为推荐值

SJ系列蜗杆升降机 SJ series worm screw elevators



型号与标记/Type and sign:

SJ 3 - a - S - A/R - 12 - 300 - P

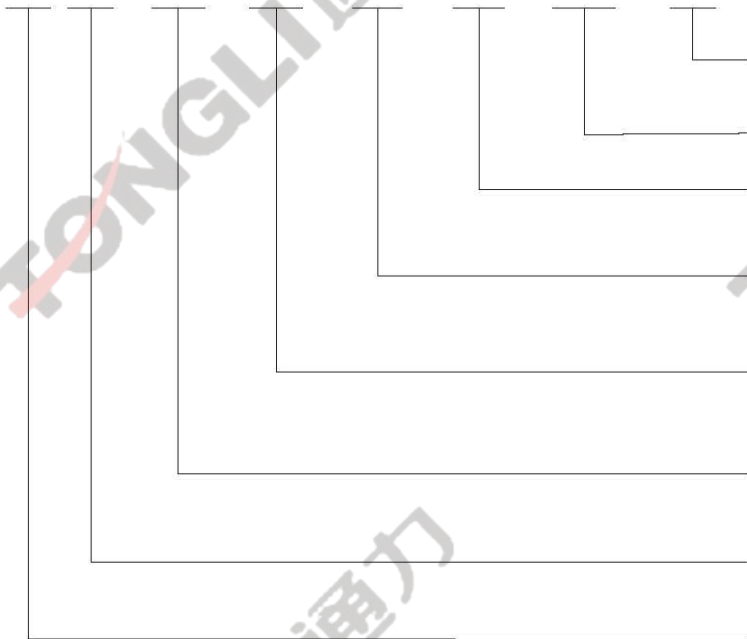

保护管: P带、N不带
P with protective pipe,
N without protective pipe

行程/Travel

传动比/Ratio

输入形式: A、B、C、D/R、L; 见SJ02页
Input shaft form: A、B、C、D/R、L;
see page 209

螺杆端型式: S、H、R、T、M;
screw head form: S、H、R、T、M;

安装形式: a、b、c、d、e、f; 见SJ02页
mounting positions: a、b、c、d、e、f;
see page 209

举升力(3吨)/Lift power (3T)

类型/Type

SJ系列蜗杆升降机结构示意图

SJ Structural representation of SJ series worm screw elevators

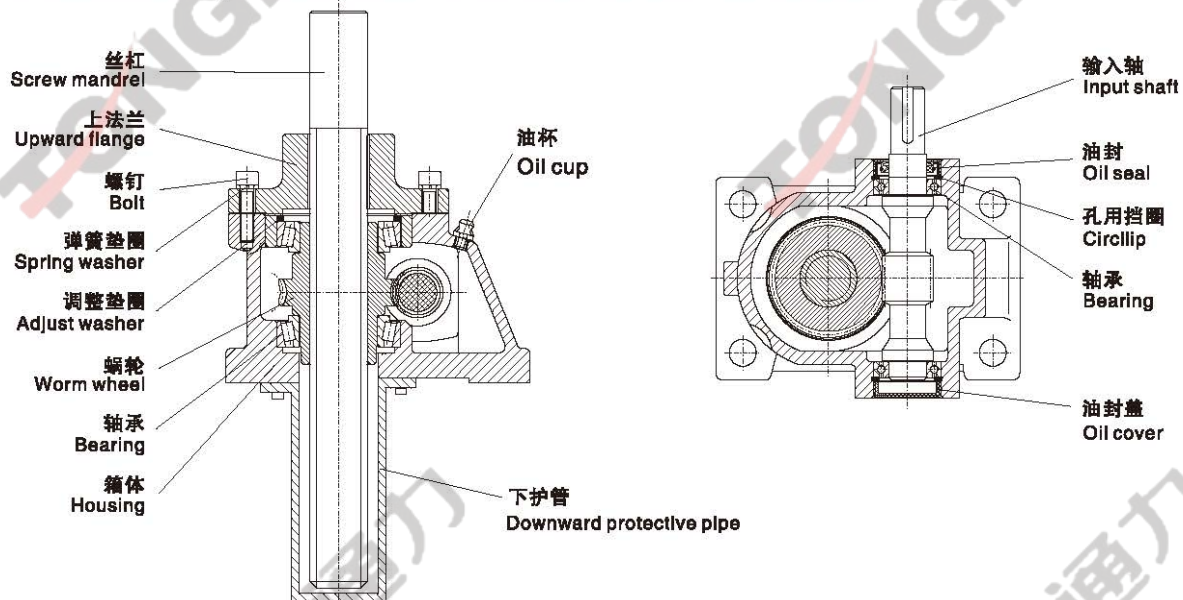

最大负荷及丝杠参数 / General parameters Maximum Load and Screw parameters

型号 Size	SJ2	SJ3	SJ5	SJ10	SJ15	SJ20	SJ30	SJ40	SJ50	SJ100
丝杠外径X螺距 Screw diameter multiple pitch (mm)	φ 25X5	φ 32X6	φ 38X6	φ 45X8	φ 50X8	φ 65X10	φ 75X12	φ 80X12	φ 90X14	φ 100X16
螺纹底部直径 Worm bottom diameter	φ 19.5	φ 25	φ 31	φ 36	φ 41	φ 54	φ 62	φ 67	φ 74	φ 82
重量 (行程100) weigh	15.5kg	30.5kg	48kg	60kg	73kg	118kg	131kg	189kg	262kg	393kg

输入形式/Input shaft form:

A.单输入/Single input shaft		B.双输入/Double input shaft	
R.右轴输入/Input shaft on the right	L.左轴输入/Input shaft on the left		
C.直联单输入/Direct single input shaft		D.直联双输入/Direct double input shaft	
R.右法兰直联/Flange direct conjoint on the right		L.左法兰直联/Flange direct conjoint on the left	
R.右直联双输入/Direct double input shaft on the right		L.左直联双输入/Direct double input shaft on the left	

SJ

02 安装方式/Mouting positions:

以举升量防止螺杆接头转动 Lift power can prevent screw lie-in rotate		以楔子固定升降螺杆防止其转动 (丝杆可上下,不旋转) The chock fix fluctuating screw to prevent it rotate (screw mandrel can fluctuate but not rotate)		螺杆旋转—外活动螺帽必须与升降机件接合,升降机件应予固定使之转动一致 One outer active screw nut must be conjoined lift machine element when screw rotate, Lift machine element should be fixed to rotate according with screw nut.	
双管直立式 Double tubes perpendicularity model	双管倒立式 Double tubes handstand model	锁定直立式 Lock perpendicularity mode	锁定倒立式 Lock handstand model	旋转直立式 Circumrotate perpendicularity mode	旋转倒立式 Circumrotate handstand model



SJ系列升降机 选型方法

1. 初步确定升降机型号

1.1 计算考虑负荷性质的当量总负荷 F_w

$$F_w = F \times K \quad (\text{kN})$$

式中:

F ——总负荷 (kN)

K ——负荷系数 (见表)

负荷类型	K
无冲击、负荷惯性小	1.0 ~ 1.3
轻微冲击、负荷惯性中等	1.3 ~ 1.5
大冲击振动、负荷惯性大	1.5 ~ 3.0

1.2 计算单台升降机当量负荷 F_A

$$F_A = \frac{F_w}{c \times f} \quad (\text{kN})$$

式中:

c ——联动台数

f ——联动系数 (见表)

c	1	2	3	4	5~8
f	1	0.95	0.9	0.85	0.8

1.3 初定升降机型号

充分考虑起升速度, 总效率, 单台升降机负荷不能超过其允许最大负荷, 初步确定升降机型号。

2 输入功率校核

2.1 所需输入轴转速 n_a 计算

$$n_a = \frac{v \times i}{p} \quad (\text{rpm})$$

式中:

v ——起升速度 (mm/min)

i ——传动比

p ——丝杠螺距 (mm)

升降机性能参数表中, 选取输入转速 $n_1 \geq n_a$

2.2 所需输入功率 P_1 计算

$$P_1 = \frac{F_A \times v}{60000 \times \eta} \quad (\text{kW})$$

式中:

η ——总效率

(见升降机性能参数表中 n_1 所在档)

若 $P_1 <$ 容许最大输入功率 (升降机性能参数表中 n_1 所在档), 满足要求。如果超过, 须提高型号或降低起升速度。

SJ series Screw Worm Elevator selection method

1. Preliminarily determine elevator type

1.1 Calculate the equivalent load F_w with the load type considered

$$F_w = F \times K \quad (\text{kN})$$

F ——Total load (kN)

K ——load factor (see table below)

Load type	K
No impact, low inertia load	1.0 ~ 1.3
Light impact, medium inertia load	1.3 ~ 1.5
Heavy impact, high inertia load	1.5 ~ 3.0

1.2 Calculate the equivalent load F_A of single elevator

$$F_A = \frac{F_w}{c \times f} \quad (\text{kN})$$

c ——Number of linkage elevators

f ——Linkage factor (see table below)

c	1	2	3	4	5~8
f	1	0.95	0.9	0.85	0.8

1.3 Preliminarily determine elevator type

Preliminarily determine elevator type with full consideration of speed, efficiency and the single load not exceed permitted maximum load.

2 Check input power

2.1 Calculate the required input shaft speed n_a

$$n_a = \frac{v \times i}{p} \quad (\text{rpm})$$

v ——Linear speed (mm/min)

i ——Transmission ratio

p ——Pitch of screw (mm)

Select the input shaft speed $n_1 \geq n_a$ from the Elevator Performance Parameter Table.

2.2 Calculate the required input power P_1

$$P_1 = \frac{F_A \times v}{60000 \times \eta} \quad (\text{kW})$$

η ——Total efficiency

(see the Elevator Performance Parameter Table under the n_1 archives)

If $P_1 <$ permitted maximum input power (see the Elevator Performance Parameter Table in the n_1 ranges), meet the requirement. Otherwise, select larger size or reduce the linear speed.

2.3 校核输入轴扭矩 T_1

校核输入轴强度时，自驱动源到各串联升降机顺序，前者是后者各台扭矩之和。

3 丝杠稳定性校核

当丝杠承受轴向压力负荷时，须对丝杠进行容许弯曲负荷校核。

根据底座及轴端联接方式按图表进行校核，若超过临界负荷，须提高型号。

4 注意事项

4.1 升降机正常工作环境温度 $-20^{\circ}\text{C} \sim 40^{\circ}\text{C}$ ，环境温度超过 40°C 时，应考虑减小工作持续率。

4.2 充分考虑起升速度和起升负荷的搭配，升降机允许输入功率不仅与起升负荷，而且与起升速度有关系。

4.3 同一轴线联接多台升降机时，应对升降机输入轴端强度进行校核。

4.4 当有横向负荷时，请加导向装置。

5 选型示例

已知：4台联动举升装置，无冲击负荷，惯性小

总负荷 $F = 200\text{kN}$

起升速度 $v = 140\text{mm/min}$

负荷系数 $K = 1.1$

联动系数 $f = 0.85$

5.1 计算当量总负荷 F_w

$$F_w = F \times K = 200 \times 1.1 = 220\text{kN}$$

5.2 计算单台升降机当量负荷 F_A

$$F_A = \frac{F_w}{c \times f} = \frac{220}{4 \times 0.85} = 64.706\text{kN}$$

根据此初选SJ30型升降机，传动比 $i = 18$ ，螺距 $p = 12\text{mm}$ 。

5.3 输入功率校核

$$n_a = \frac{v \times i}{p} = \frac{140 \times 18}{12} = 210\text{rpm}$$

n_1 在输入转速300rpm档里

总效率 $\eta = 0.14$

容许最大输入功率 $[P_1] = 1.56\text{ kW}$

$$P_1 = \frac{F_A \times v}{60000 \times \eta} = \frac{64.706 \times 140}{60000 \times 0.14} = 1.078\text{kW} < [P_1]$$

合格。

以下略。

2.3 Check the torque T_1 applied on input shaft Input shaft strength should be checked from the driver side to the individual series elevator in sequence, the torque of the former one is the sum of all the latter ones.

3 Check the stability of screw

In case the screw bears axial pressure, permitted bending load should be checked.

Check according to the chart based on the joint types of the base and the shaft end, in case beyond critical load, please select larger size.

4 Attentions

4.1 Please keep the ambient temperature in $-20^{\circ}\text{C} \sim 40^{\circ}\text{C}$ to ensure the elevator working normally. If the ambient temperature exceed 40°C , please reduce the continuous operating rate.

4.2 Please take full consideration of the match of the speed and load. The power of elevator is depended not only on the load, but also on the speed.

4.3 In case several elevators are connected on the same axial line, the load torque on the input shaft of each elevator should be checked.

4.4 In case any radial force exists, please add guiding device.

5 Selection example

Given: Four elevators linked as lifting device, no impact load, low inertia load

Total load $F = 200\text{kN}$

Linear speed $v = 140\text{mm/min}$

Load factor $K = 1.1$

Linkage factor $f = 0.85$

5.1 Calculate the equivalent load F_w

$$F_w = F \times K = 200 \times 1.1 = 220\text{kN}$$

5.2 Calculate the equivalent load F_A of single elevator

$$F_A = \frac{F_w}{c \times f} = \frac{220}{4 \times 0.85} = 64.706\text{kN}$$

Preliminarily determine the type SJ30 elevator according to load, with ratio $i = 18$ and pitch of screw $p = 12\text{mm}$.

5.3 Check input power

$$n_a = \frac{v \times i}{p} = \frac{140 \times 18}{12} = 210\text{rpm}$$

n_1 falls in the 300 rpm input speed range

Permitted maximum input power $[P_1] = 1.56\text{ kW}$

$$P_1 = \frac{F_A \times v}{60000 \times \eta} = \frac{64.706 \times 140}{60000 \times 0.14} = 1.078\text{kW} < [P_1]$$

Satisfied.

Following steps are omitted here.

选型指南 Guidelines for the selection



容许弯曲负荷值:

关于各种型号及轴端各种负荷方式, 有关牙杆长度及容许弯曲负荷可参考以下表格或计算式。

计算方法:

$$P_{cr} = n \pi^2 E (K/L)^2 \cdot A \cdot \alpha$$

n : 轴端支承系数

E : 弹性模量

$$2.06 \times 10^5 \text{ N/mm}^2$$

K : 最小惯性半径

$$K = d_1/4$$

d_1 : 螺纹底部直径

L : 轴支承长度

A : 举升螺杆螺纹底部直径的截面积

$$A = \pi (d_1)^2/4$$

α : 安全系数 $\alpha = 0.25$

P_{cr} : 容许弯曲负荷

Permit bended load value:

All kinds of type and load mode of axle head, the length of screw mandrel and permit bended load vale may consult the following table or calculate formula

Calculate method:

$$P_{cr} = n \pi^2 E (K/L)^2 \cdot A \cdot \alpha$$

n : support factor of axle head

E : Elastic modulus

$$2.06 \times 10^5 \text{ N/mm}^2$$

K : minimum assistant radius

$$K = d_1/4$$

d_1 : worm bottom diameter

L : axial support length

A : worm bottom's cross section of lift screw

$$A = \pi (d_1)^2/4$$

α : safe factor $\alpha = 0.25$

P_{cr} : permit bended load vale may consult

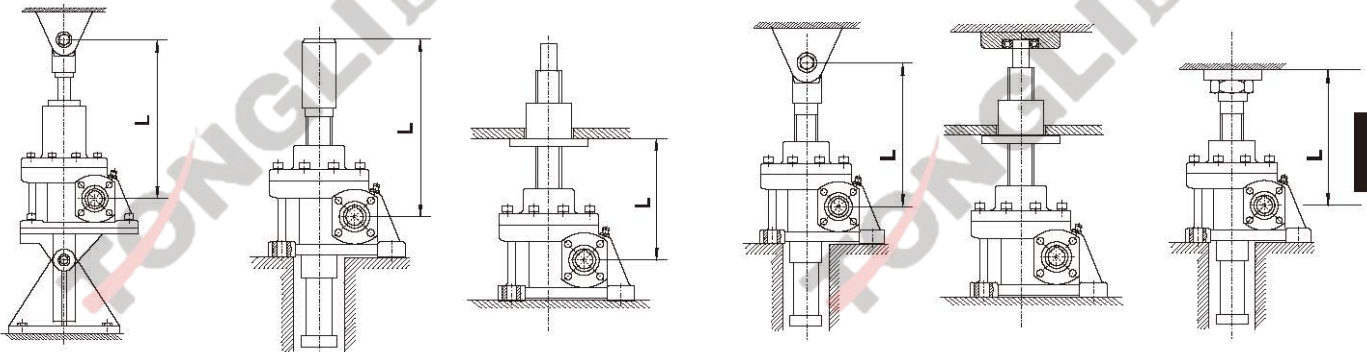

底座支承—轴端支承
Pedestal support—Axle head support

底座固定—轴端自由
Fixed pedestal—Uncontrolled axle head

底座固定—轴端固定或支撑
Fixed pedestal—Fixed axle head or axle head support

SJ

05

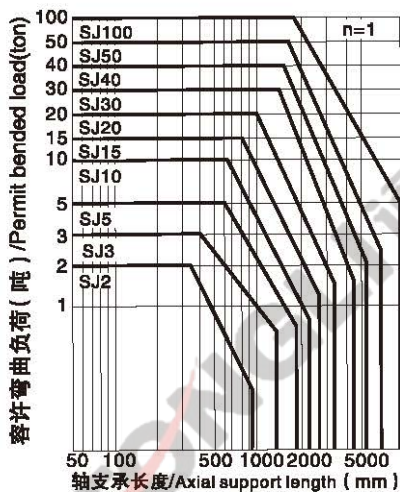

底座支承—轴端支承
Pedestal support—Axle head support

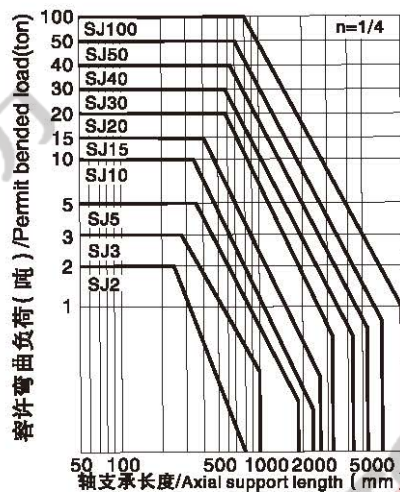

底座固定—轴端自由
Fixed pedestal—Uncontrolled axle head

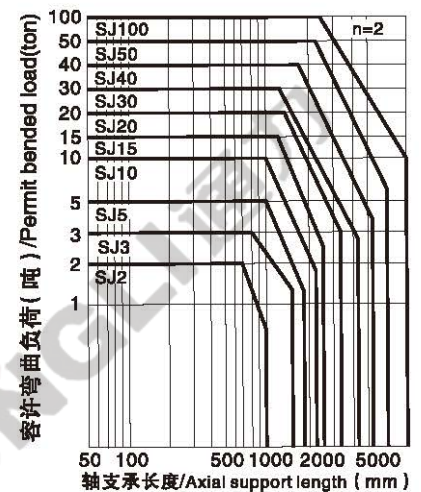

底座固定—轴端固定或支撑
Fixed pedestal—Fixed axle head or axle head support

升降机性能参数表 / Elevator performance table

型号 Size	最大负荷 Maximum Load kN	丝杠外径 × 螺距 Screw diameter multiple pitch mm	传动比 Ratio i	输入轴转速 rpm											
				1800				1500				1200			
				输入功率 Input power kW	总效率 Total power η	起升负荷 Lift Speed kN	起升速度 Linear speed mm/min	输入功率 Input power kW	总效率 Total power η	起升负荷 Lift Speed kN	起升速度 Linear speed mm/min	输入功率 Input power kW	总效率 Total power η	起升负荷 Lift Speed kN	起升速度 Linear speed mm/min
SJ2	20	Tr25×5	5	0.69	0.22	5.00	1800	0.64	0.21	5.50	1500	0.65	0.22	7.00	1200
			10	0.37	0.20	5.00	900	0.37	0.19	5.50	750	0.37	0.19	7.00	600
			20	0.37	0.12	6.00	450	0.37	0.12	7.00	375	0.37	0.12	9.00	300
SJ3	30	Tr32×6	6	0.98	0.21	7.00	1800	0.93	0.22	8.00	1500	0.88	0.22	9.50	1200
			12	0.66	0.22	9.50	900	0.64	0.21	11.00	750	0.60	0.22	13.00	600
			24	0.37	0.19	9.50	450	0.37	0.19	11.00	375	0.37	0.18	13.00	300
SJ5	50	Tr38×6	6	1.39	0.19	9.00	1800	1.28	0.20	10.00	1500	1.24	0.19	12.00	1200
			12	1.10	0.18	13.50	900	1.01	0.19	15.00	750	0.98	0.18	18.00	600
			24	0.78	0.17	18.00	450	0.72	0.17	20.00	375	0.69	0.17	24.00	300
SJ10	100	Tr45×8	8	2.12	0.18	13.00	1800	1.97	0.18	14.50	1500	1.85	0.18	17.00	1200
			16	1.12	0.17	13.00	900	1.04	0.17	14.50	750	0.98	0.17	17.00	600
			32	0.80	0.16	17.50	450	0.75	0.16	19.50	375	0.69	0.16	22.50	300
SJ15	150	Tr50×8	8	2.01	0.19	13.00	1800	1.87	0.19	14.50	1500	1.75	0.19	17.00	1200
			16	1.06	0.18	13.00	900	0.99	0.18	14.50	750	0.93	0.18	17.00	600
			32	0.75	0.18	17.50	450	0.70	0.17	19.50	375	0.65	0.17	22.50	300
SJ20	200	Tr65×10	10	2.66	0.16	14.00	1800	2.42	0.19	18.50	1500	2.25	0.17	19.50	1200
			20	1.42	0.17	16.00	900	1.47	0.16	18.50	750	1.37	0.16	22.50	600
			40	1.14	0.16	24.00	450	1.17	0.15	28.00	375	1.09	0.15	33.50	300
SJ30	300	Tr75×12	12	3.63	0.15	18.00	1800	3.51	0.15	21.50	1500	3.40	0.15	26.00	1200
			18	2.66	0.14	19.00	1200	2.68	0.14	23.00	1000	2.57	0.14	27.50	800
			36	1.66	0.13	22.00	600	1.63	0.13	26.00	500	1.60	0.13	32.00	400
SJ40	400	Tr80×12	12	4.15	0.14	19.75	1800	4.02	0.14	23.00	1500	3.81	0.14	27.25	1200
			18	3.20	0.13	21.25	1200	3.20	0.13	25.50	1000	3.04	0.13	30.25	800
			36	2.14	0.12	26.25	600	2.07	0.12	30.50	500	1.99	0.12	36.50	400
SJ50	500	Tr90×14	7	9.48	0.13	21.00	3600	9.18	0.13	24.50	3000	9.03	0.13	28.50	2400
			14	5.76	0.12	23.50	1800	5.72	0.12	28.00	1500	5.58	0.12	33.00	1200
			28	4.07	0.11	30.50	900	3.90	0.11	35.00	750	3.91	0.10	41.00	600
SJ100	1000	Tr100×16	8	16.27	0.13	35.00	3600	16.04	0.12	40.00	3000	15.82	0.14	54.00	2400
			16	11.72	0.11	43.00	1800	11.57	0.12	54.00	1500	10.52	0.14	72.00	1200
			32	8.66	0.10	55.00	900	9.55	0.09	68.00	750	7.36	0.14	100.0	600

性能参数表
Perfomance Value Table



升降机性能参数表 / Elevator performance table

型号 Size	最大负荷 Maximum Load kN	丝杠外径 × 螺距 Screw diameter multiple pitch mm	传动比 Ratio i	输入轴转速 rpm											
				900				600				300			
				输入功率 Input power kW	总效率 Total power η	起升负荷 Lift Speed kN	起升速度 Linear speed mm/min	输入功率 Input power kW	总效率 Total power η	起升负荷 Lift Speed kN	起升速度 Linear speed mm/min	输入功率 Input power kW	总效率 Total power η	起升负荷 Lift Speed kN	起升速度 Linear speed mm/min
SJ2	20	Tr 25×5	5	0.63	0.21	9.00	900	0.46	0.22	10.00	600	0.37	0.14	10.00	300
			10	0.37	0.15	7.50	450	0.37	0.14	10.00	300	0.19	0.18	13.50	150
			20	0.37	0.12	12.00	225	0.19	0.18	13.50	150	0.19	0.09	13.50	75
SJ3	30	Tr 32×6	6	0.91	0.21	13.00	900	0.84	0.21	18.00	600	0.42	0.21	18.00	300
			12	0.57	0.22	16.50	450	0.46	0.22	20.00	300	0.37	0.14	20.00	150
			24	0.37	0.17	16.50	225	0.37	0.14	20.00	150	0.19	0.13	20.00	75
SJ5	50	Tr 38×6	6	1.16	0.19	15.00	900	0.87	0.20	17.00	600	0.54	0.19	21.00	300
			12	0.87	0.19	21.50	450	0.58	0.19	21.50	300	0.37	0.17	25.00	150
			24	0.54	0.18	25.50	225	0.42	0.17	29.00	150	0.37	0.10	28.00	75
SJ10	100	Tr 45×8	8	1.72	0.18	21.00	900	1.66	0.18	30.50	600	1.31	0.18	48.00	300
			16	0.95	0.17	22.00	450	0.87	0.18	30.50	300	0.69	0.17	48.00	150
			32	0.64	0.16	28.00	225	0.63	0.16	41.00	150	0.49	0.16	64.00	75
SJ15	150	Tr 50×8	8	1.62	0.19	21.00	900	1.58	0.19	30.50	600	1.24	0.19	48.00	300
			16	0.90	0.18	22.00	450	0.83	0.18	30.50	300	0.65	0.18	48.00	150
			32	0.60	0.18	28.00	225	0.59	0.17	41.00	150	0.46	0.17	64.00	75
SJ20	200	Tr65×10	10	2.12	0.17	24.50	900	1.97	0.17	33.50	600	1.41	0.17	49.00	300
			20	1.28	0.16	28.00	450	1.18	0.16	38.50	300	0.86	0.16	56.00	150
			40	1.07	0.15	44.00	225	1.97	0.15	57.50	150	0.69	0.15	84.00	75
SJ30	300	Tr75×12	12	3.19	0.15	32.50	900	2.94	0.15	45.00	600	2.09	0.15	64.00	300
			18	2.45	0.14	35.00	600	2.19	0.14	47.00	400	1.56	0.14	67.00	200
			36	1.47	0.13	39.00	300	1.36	0.13	54.00	200	1.20	0.13	96.00	100
SJ40	400	Tr 80×12	12	3.81	0.14	36.25	900	3.49	0.14	49.75	600	2.48	0.14	70.50	300
			18	3.04	0.13	40.25	600	2.74	0.13	54.50	400	1.94	0.13	77.25	200
			36	1.99	0.12	48.75	300	1.80	0.12	66.00	200	1.40	0.12	103.0	100
SJ50	500	Tr 90×14	7	8.58	0.14	40.00	1800	8.21	0.13	54.50	1200	5.84	0.13	77.50	600
			14	5.40	0.13	45.50	900	5.07	0.12	62.00	600	3.58	0.12	87.50	300
			28	3.66	0.12	58.50	450	3.48	0.11	78.00	300	2.45	0.11	110.0	150
SJ100	1000	Tr100×16	8	15.08	0.14	71.00	1800	14.85	0.13	98.50	1200	9.70	0.13	129.5	600
			16	10.97	0.13	94.50	900	9.63	0.12	118.00	600	7.09	0.12	173.5	300
			32	7.54	0.14	143.00	450	7.02	0.11	157.50	300	5.81	0.11	260.5	150

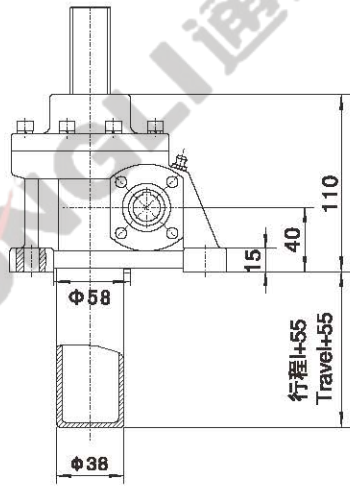

双输入/Double input shaft

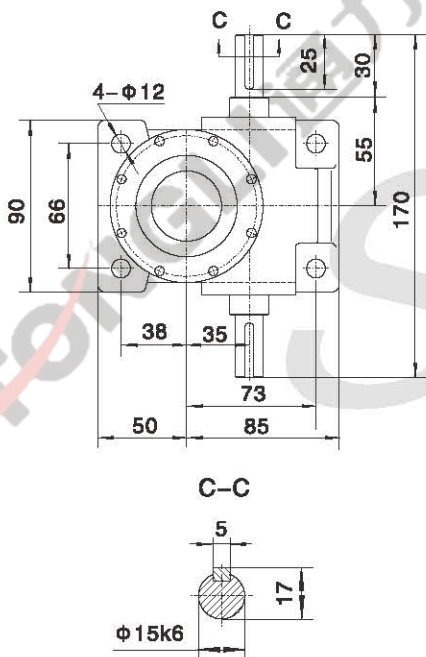

M型 / M shape

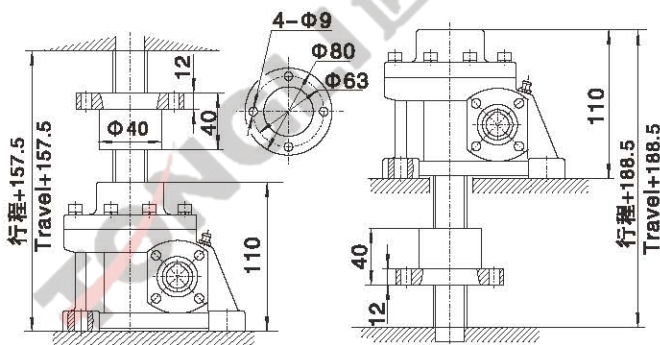

S型(牙口式)/S shape(bolt model)

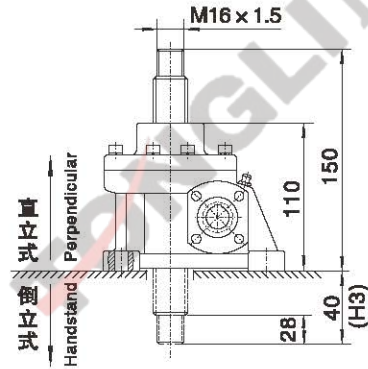

H型(栓孔式)/H shape(keyhole model)

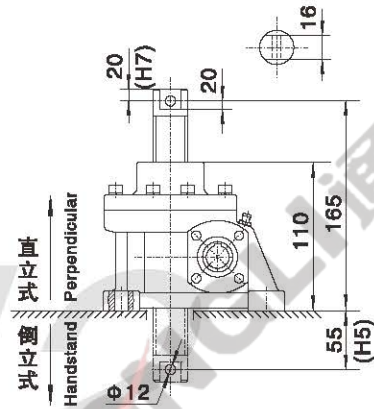

R型(平口式)/R shape(flat axle head model)

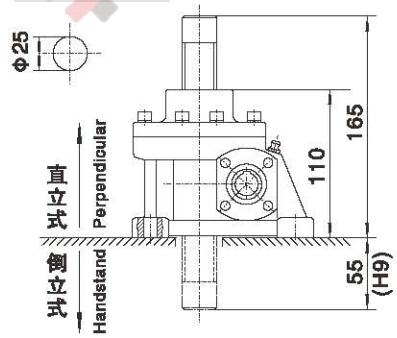

T型(顶板式)/T shape(roof model)

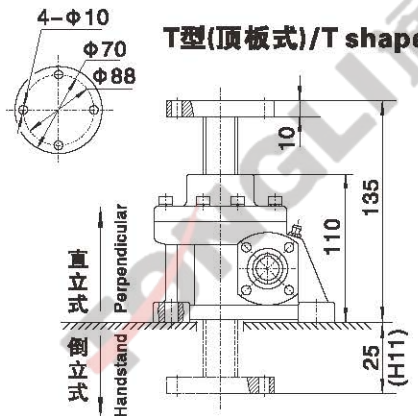

外形安装尺寸 Mounting Dimension Sheets-overview

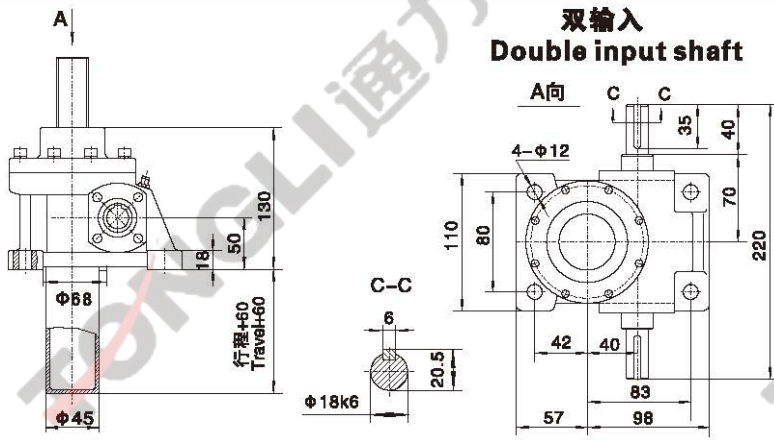

**S型(牙口式)
S shape(bolt model)**

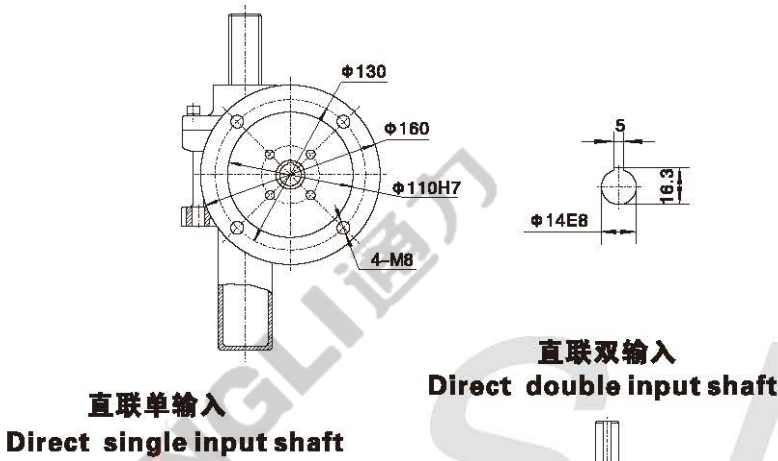
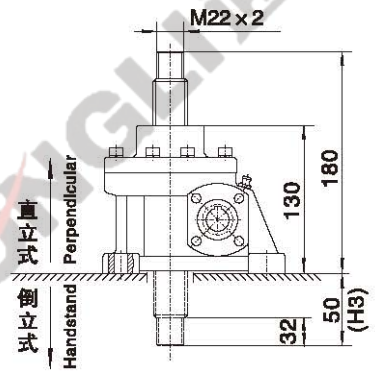

**H型(栓孔式)
H shape(keyhole model)**

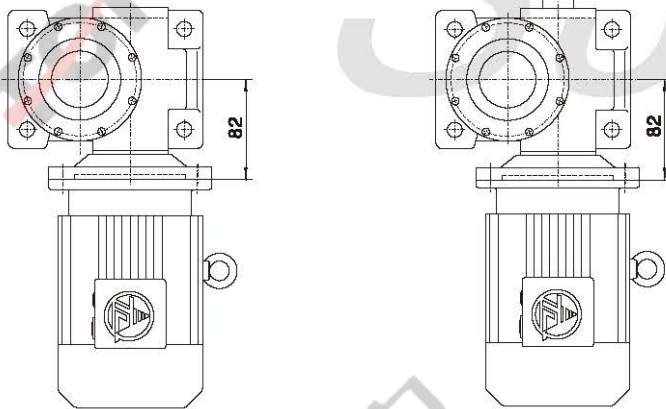
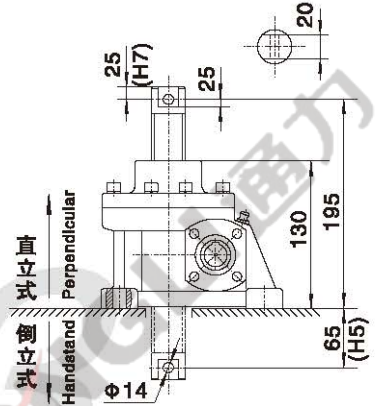

**R型(平口式)
R shape(flat axle head model)**

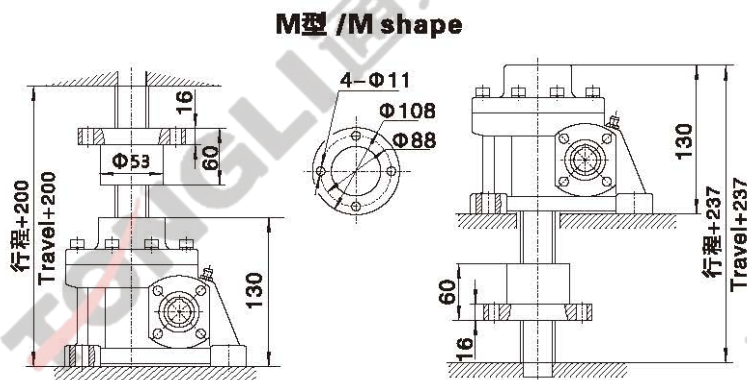
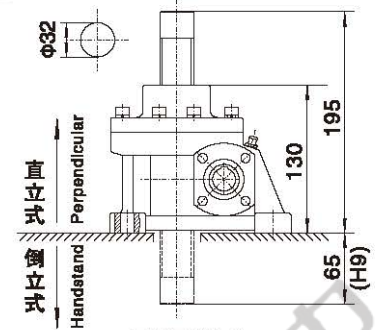

**T型(顶板式)
T shape(roof model)**

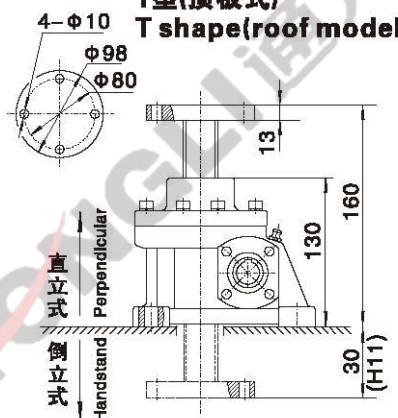

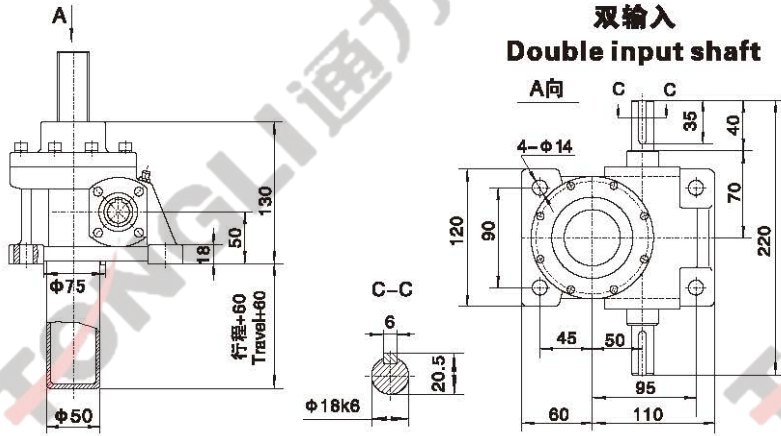

**S型(牙口式)
S shape(bolt model)**

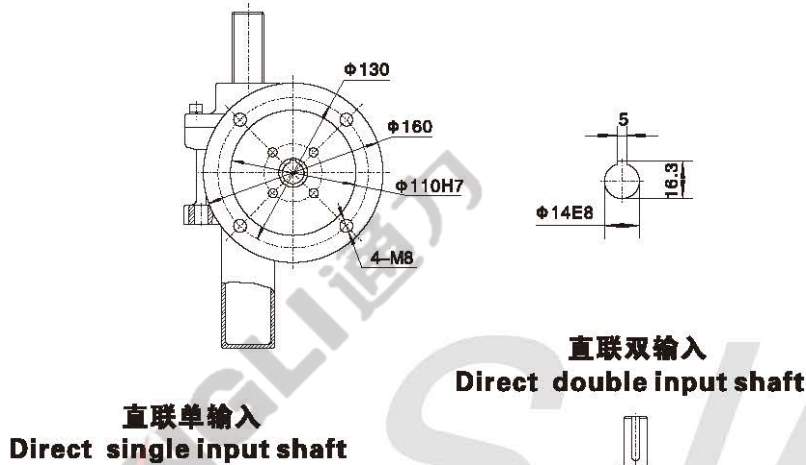
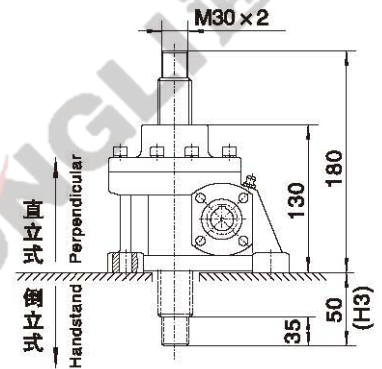

**H型(栓孔式)
H shape(keyhole model)**

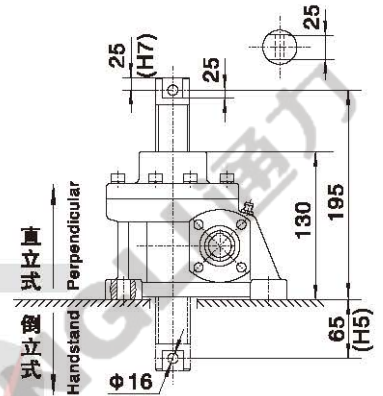

**R型(平口式)
R shape(flat axle head model)**

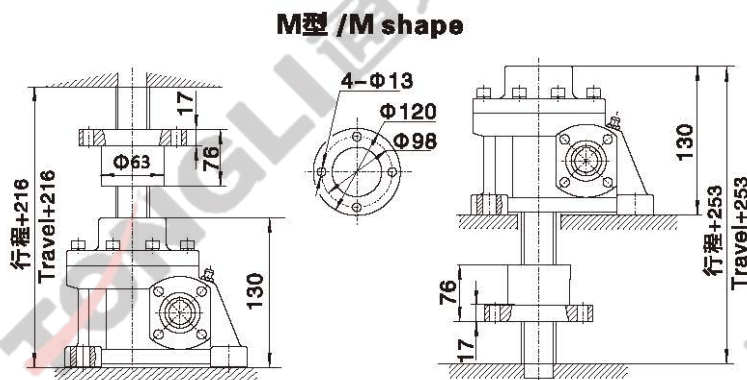
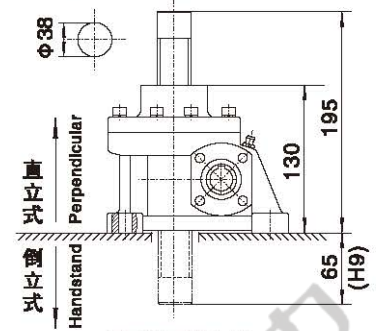

**T型(顶板式)
T shape(roof model)**

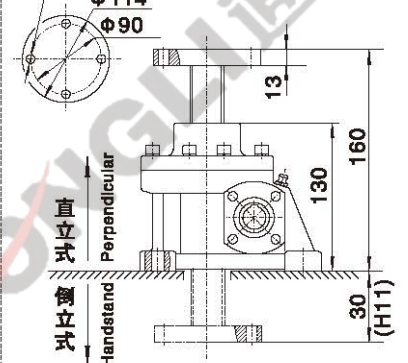

外形安装尺寸 Mounting Dimension Sheets—overview

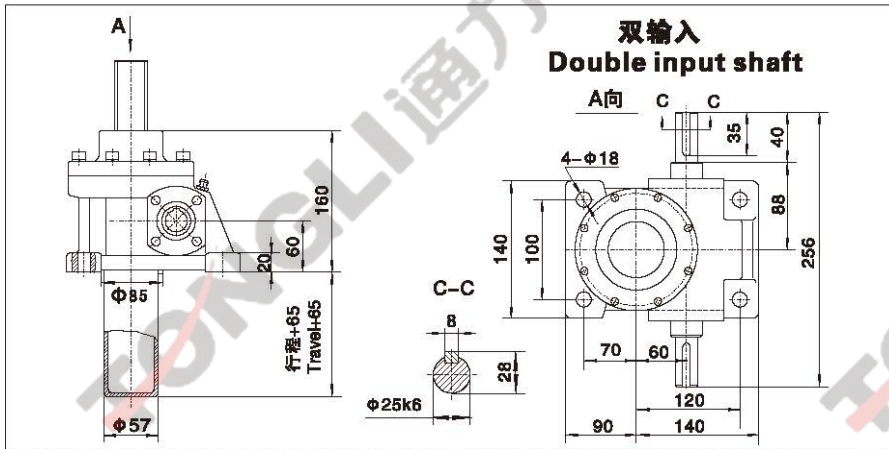

S型(牙口式) S shape(bolt model)

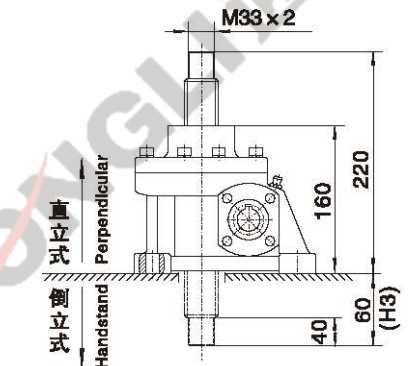

H型(栓孔式) H shape(keyhole model)

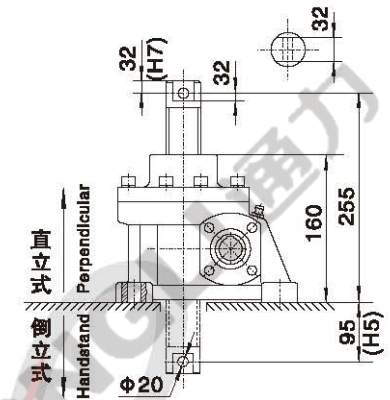

R型(平口式) R shape(flat axle head model)

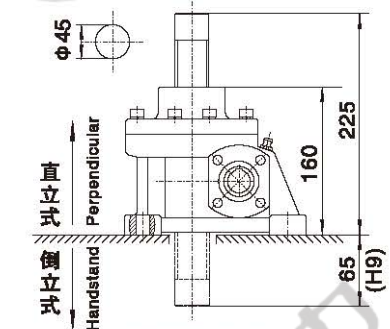

T型(顶板式) T shape(roof model)

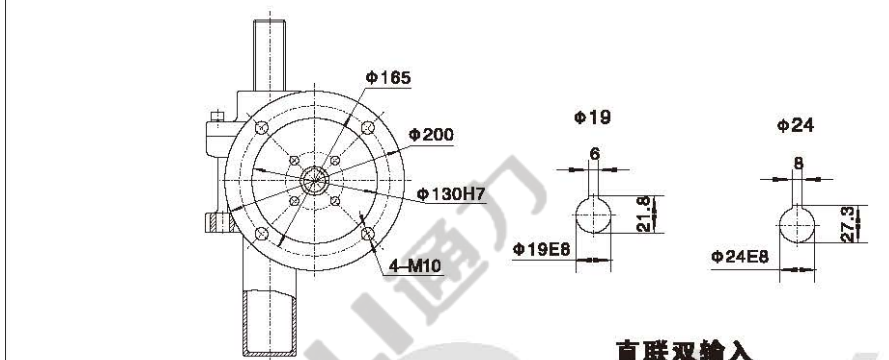
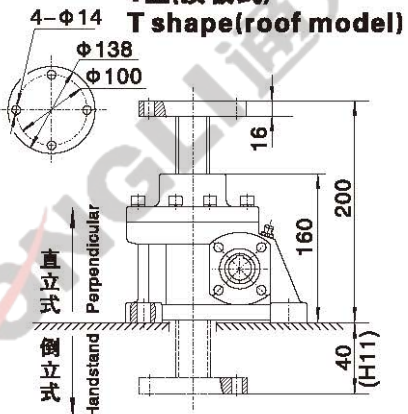

直联双输入 Direct double input shaft

直联单输入 Direct single input shaft

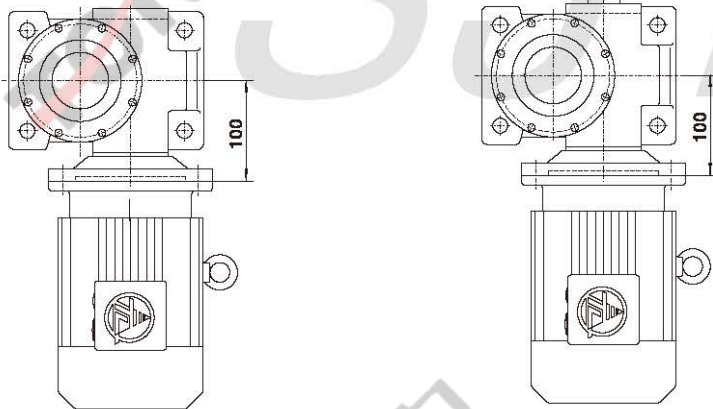

M型 / M shape

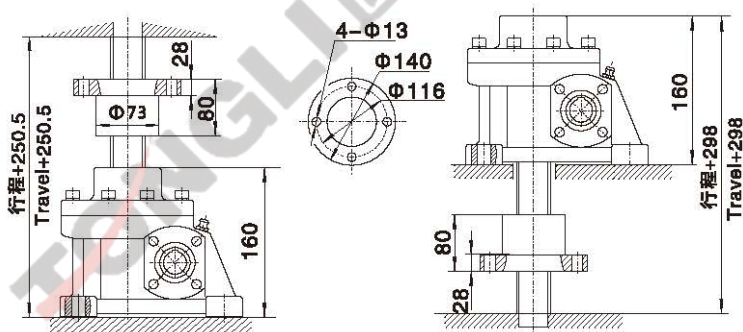

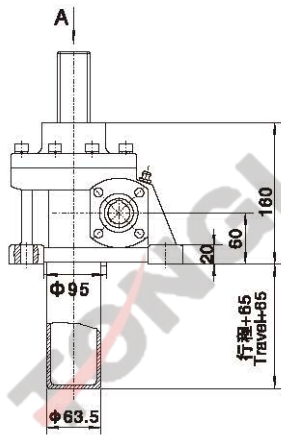

双输入
Double input shaft

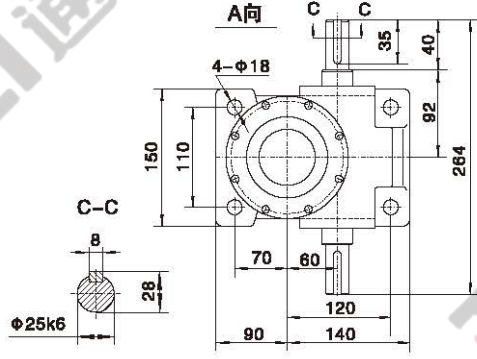

S型(牙口式)
S shape(bolt model)

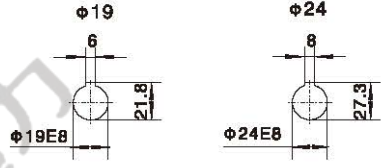
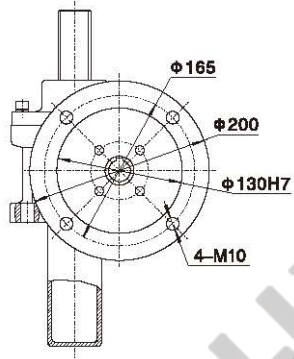
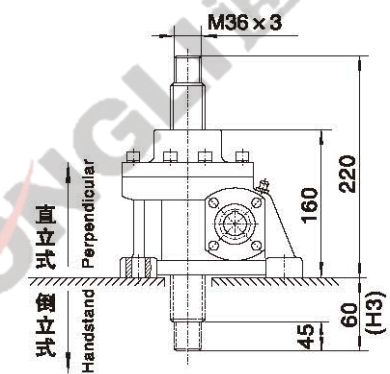

直联双输入
Direct double input shaft

H型(栓孔式)
H shape(keyhole model)

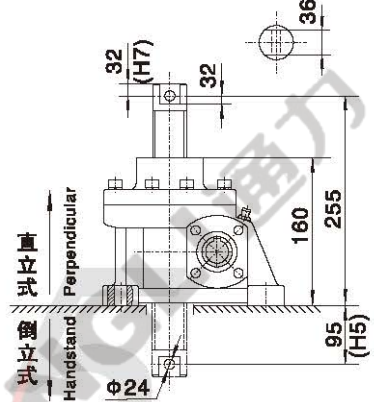

直联单输入
Direct single input shaft

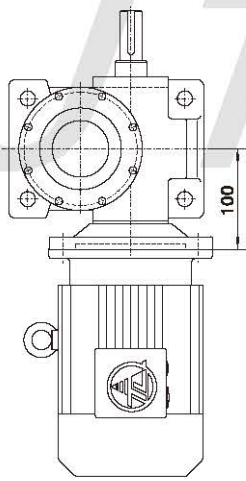
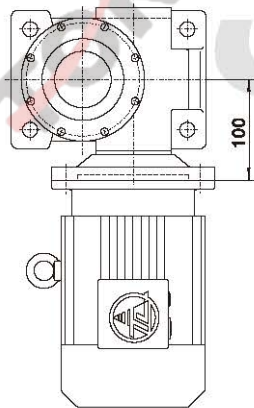

R型(平口式)
R shape(flat axle head model)

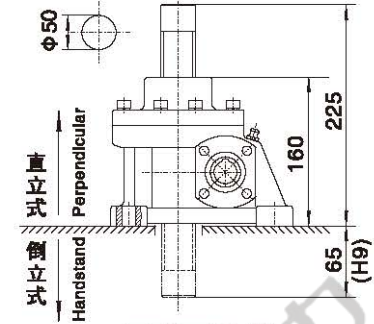

M型 /M shape

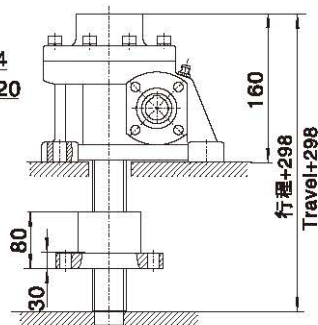
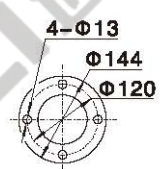
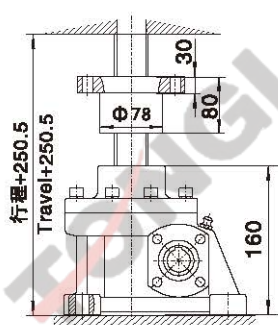

T型(顶板式)
T shape(roof model)

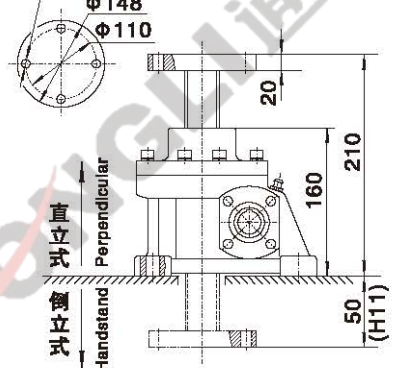

外形安装尺寸 Mounting Dimension Sheets—overview

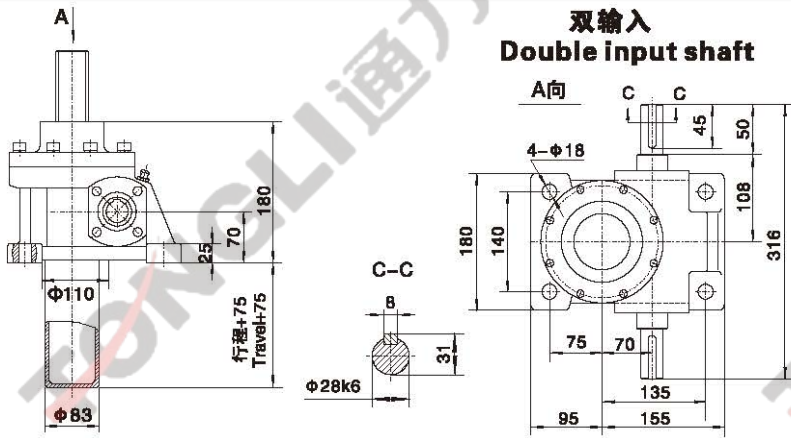

**S型(牙口式)
S shape(bolt model)**

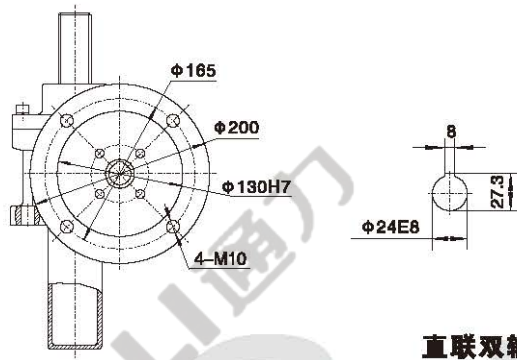
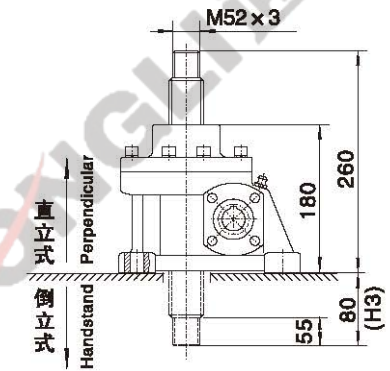

**直联双输入
Direct double input shaft**

**直联单输入
Direct single input shaft**

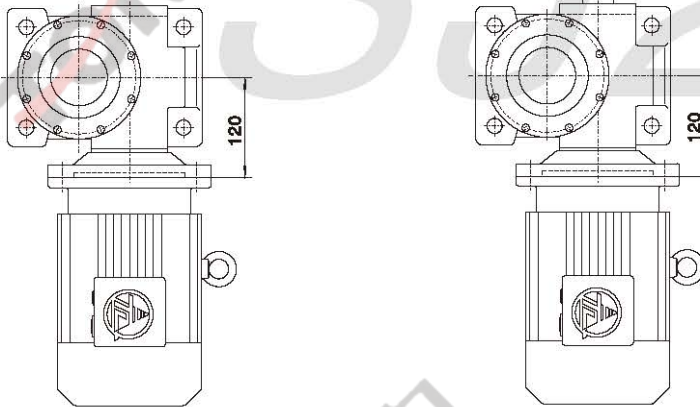

**H型(栓孔式)
H shape(keyhole model)**

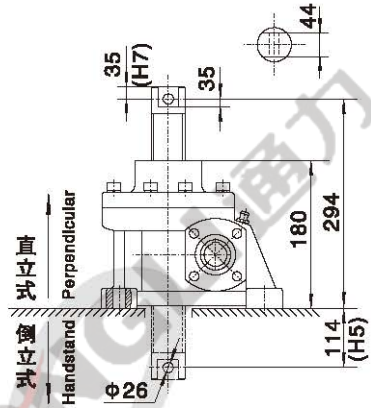

**R型(平口式)
R shape(flat axle head model)**

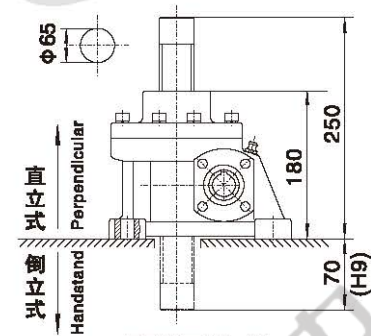

M型 / M shape

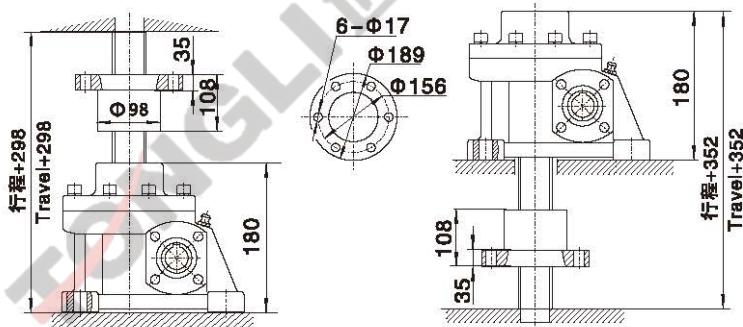

**T型(顶板式)
T shape(roof model)**

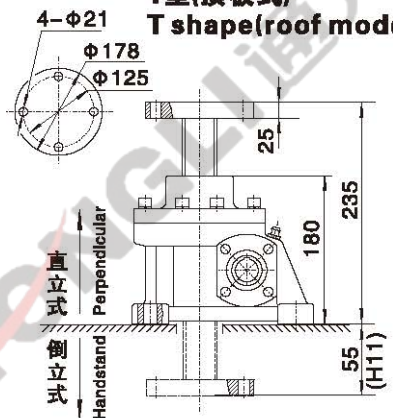

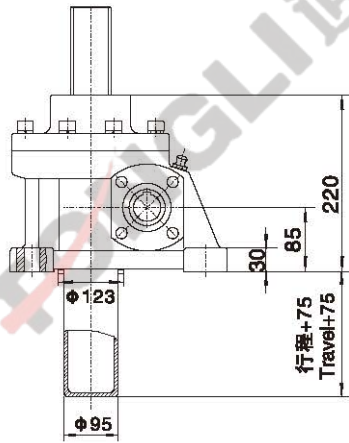

双输入
Double input shaft

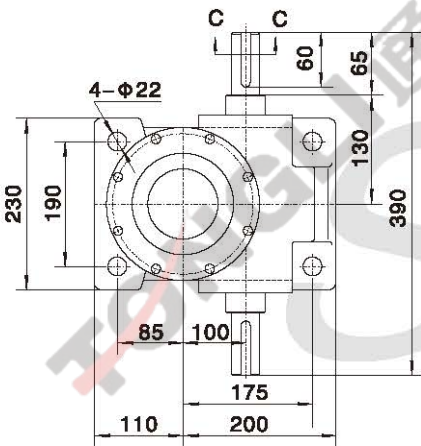

直联双输入
Direct double input shaft

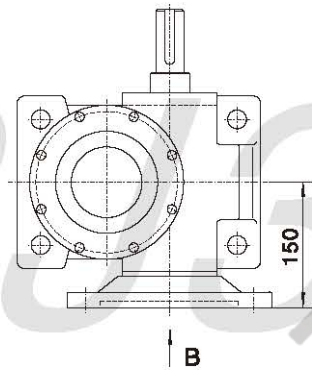

直联单输入
Direct single input shaft

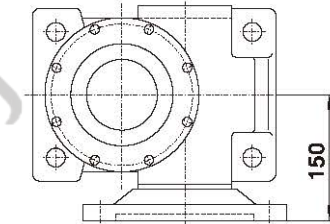
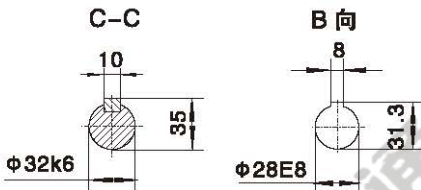

S型(牙口式)
S shape(bolt model)

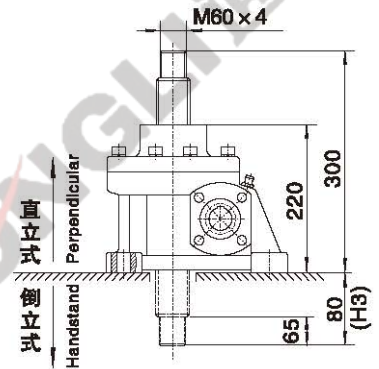

H型(栓孔式)
H shape(keyhole model)

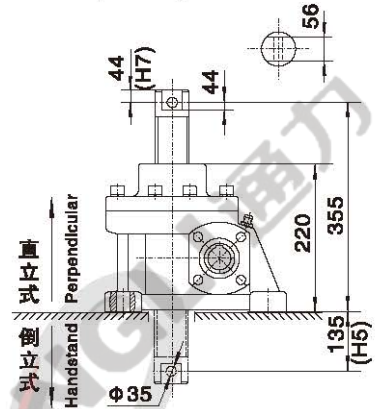

R型(平口式)
R shape(flat axle head model)

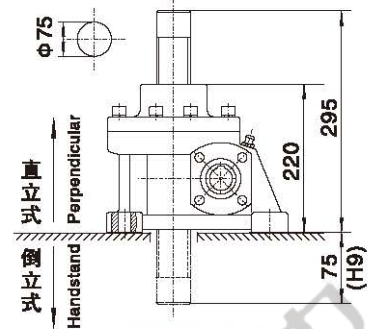

T型(顶板式)
T shape(roof model)

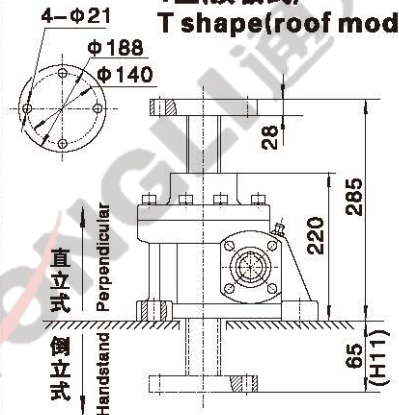

外形安装尺寸
Mounting Dimension Sheets-overview

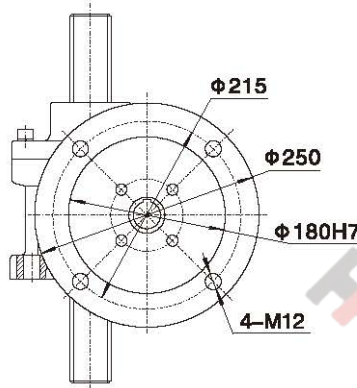
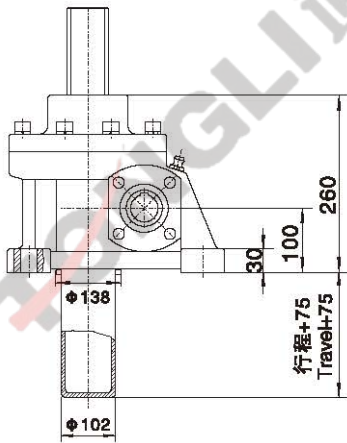

S型(牙口式)
S shape(bolt model)

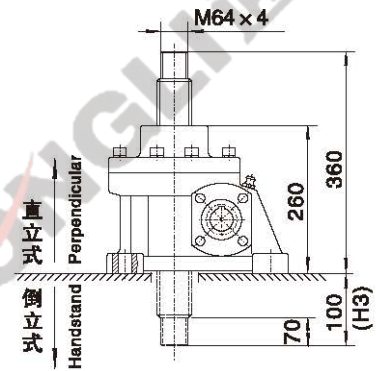

双输入
Double input shaft

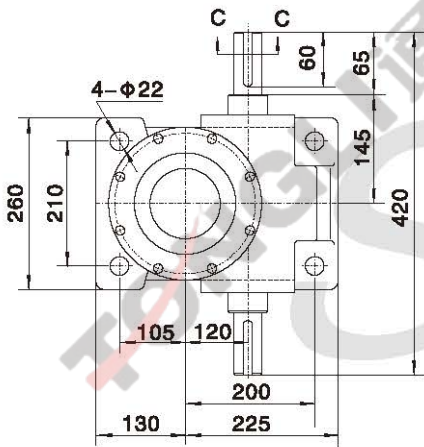

直联双输入
Direct double input shaft

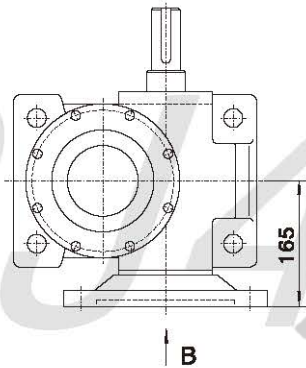

H型(栓孔式)
H shape(keyhole model)

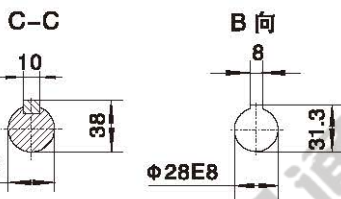
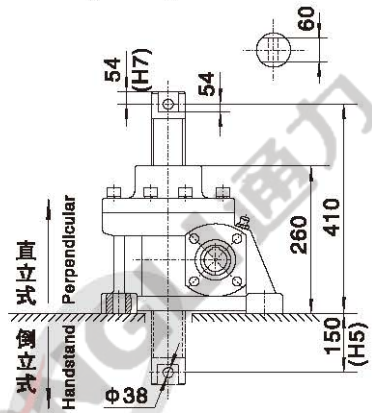

直联单输入
Direct single input shaft

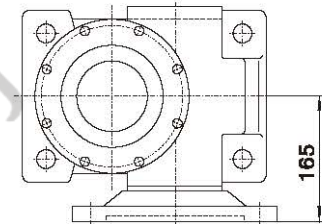

R型(平口式)
R shape(flat axle head model)

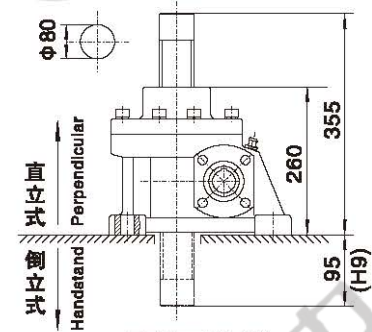

T型(顶板式)
T shape(roof model)

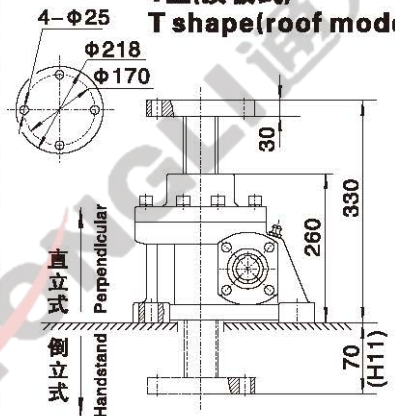

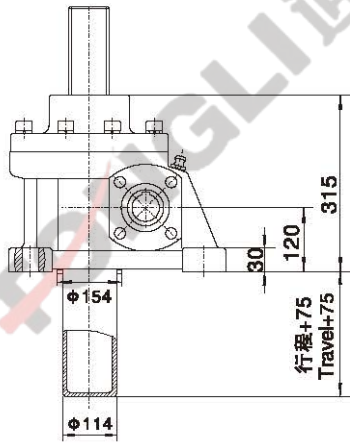

双输入
Double input shaft

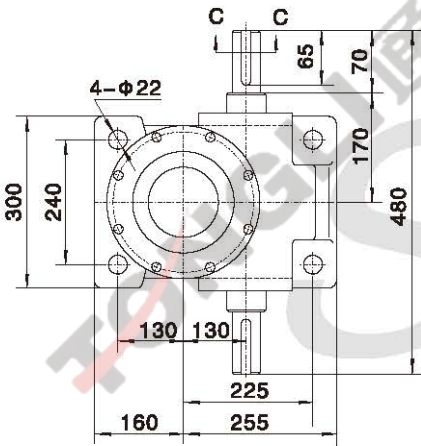

直联双输入
Direct double input shaft

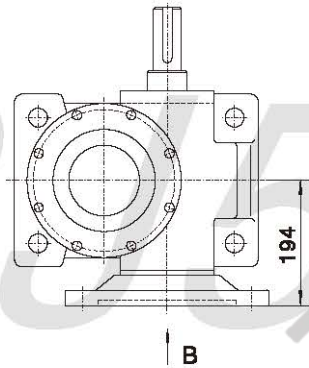

直联单输入
Direct single input shaft

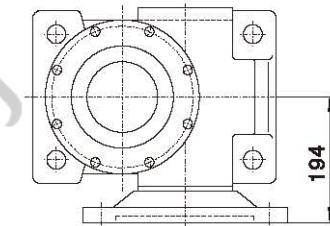
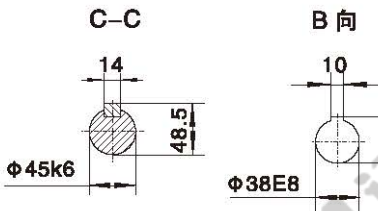

S型(牙口式)
S shape(bolt model)

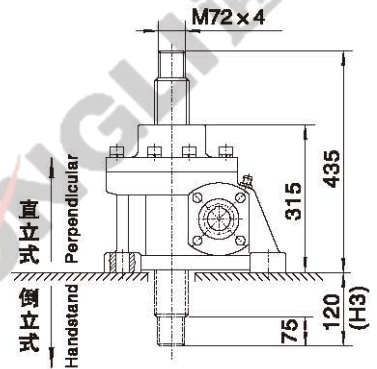

H型(栓孔式)
H shape(keyhole model)

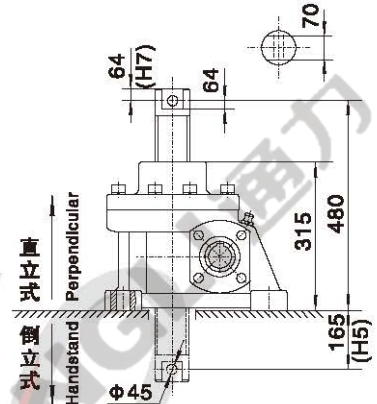

R型(平头式)
R shape(flat axle head model)

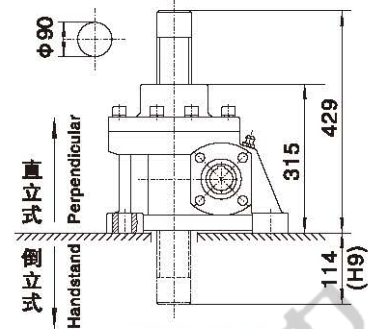

T型(顶板式)
T shape(roof model)

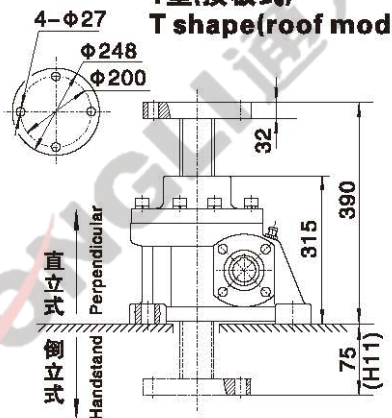

外形安装尺寸
Mounting Dimension Sheets-overview

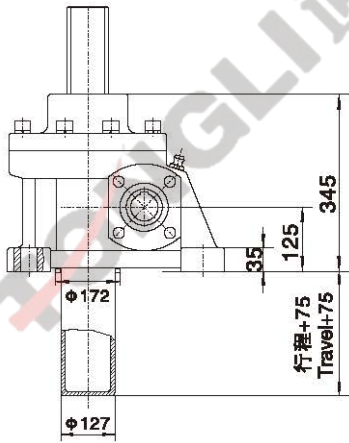

双输入
Double input shaft

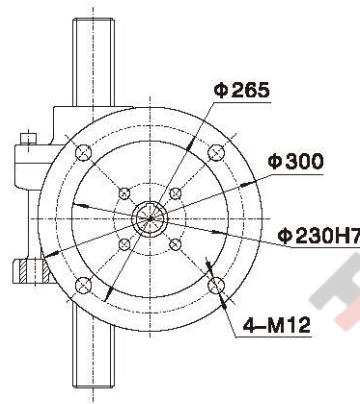
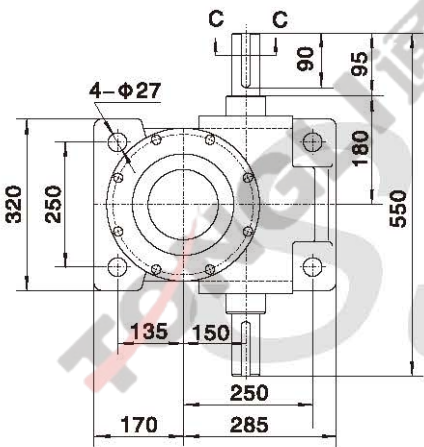

直联双输入
Direct double input shaft

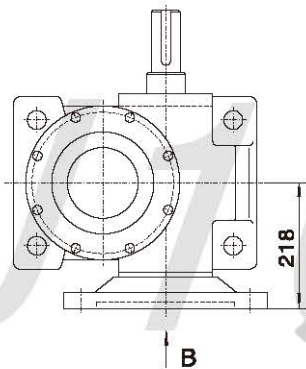

直联单输入
Direct single input shaft

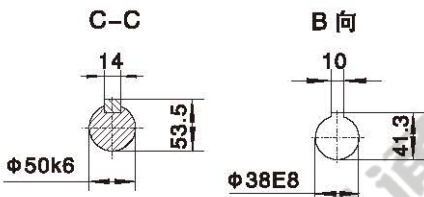
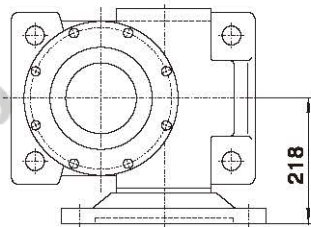

S型(牙口式)
S shape(bolt model)

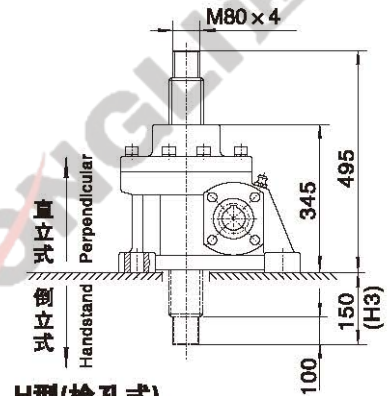

H型(栓孔式)
H shape(keyhole model)

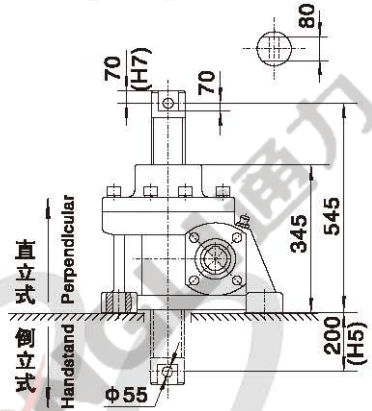

R型(平口式)
R shape(flat axle head model)

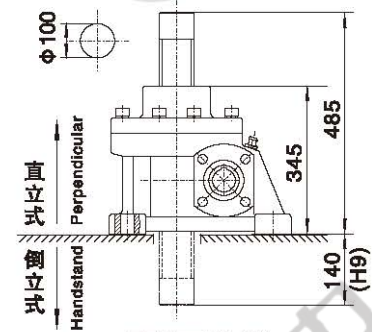

T型(顶板式)
T shape(roof model)

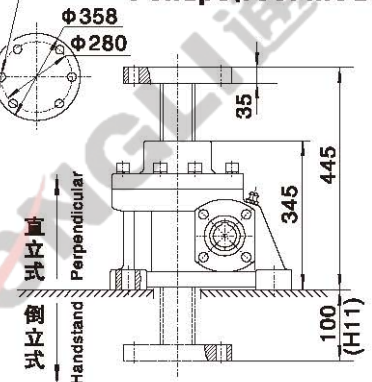

输入转向与螺杆上下运动关系如下:

The relation of input shaft veer and screw mandrel fluctuant movement as follows:

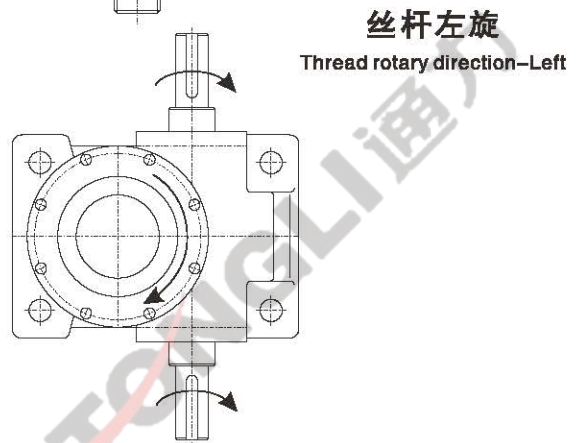
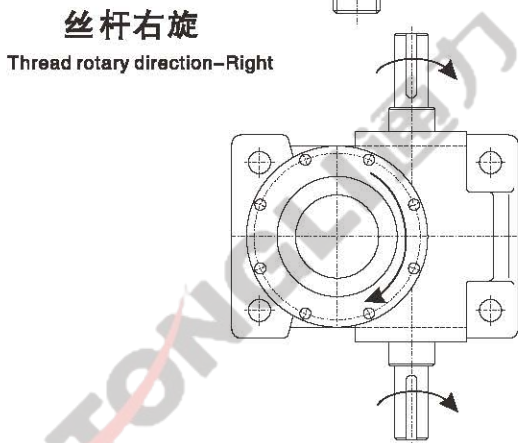
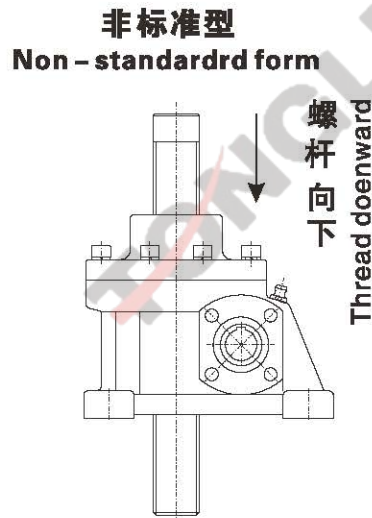
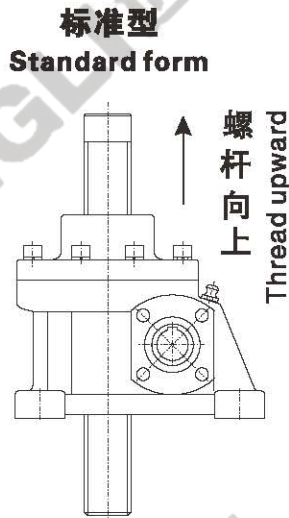

螺杆升降行程与螺杆长度计算 (下表行程=300mm各型式计算范例)

Calculate screw fluctuating travel and screw length (All kinds of calculate example when the travel=300mm)

型号 Type	直径×螺距 Diameter x pitch of screws	行程 Travel (例/Example) 300mm	杆端S型 S shape of screw head		杆端H型 H shape of screw head		杆端R型 R shape of screw head		杆端T型 T shape of screw head	
			护管长 Protective pipe length	机身+H3+行程 =螺杆总长 Mainbody length +H3+travel=total length of screw	螺杆总长-H3 =牙长 Total length of screw-H3 =screw ma- ndrel length	机身+H5+H7+行程 =螺杆总长 Mainbody length+H5 +H7+travel=total length of screw	螺杆总长-H5-H7 =牙长 Total length of screw-H5-H7 =screw mandrel length	机身+H9+行程 =螺杆总长 Mainbody length +H9+travel=total length of screw	螺杆总长-H9 =牙长 Total length of screw-H9 =screw ma- ndrel length	机身+H11+行程 =螺杆总长 Mainbody length +H11+travel=total length of screw
SJ2	Φ25×5	300+55=355	110+40+300=450	450-40=410	110+55+20+300=485	485-55-20=410	110+55+300=465	465-55=410	110+25+300=435	435-25=410
SJ3	Φ32×6	300+60=360	130+50+300=480	480-50=430	130+65+25+300=520	520-65-25=430	130+65+300=495	495-65=430	130+30+300=460	460-30=430
SJ5	Φ38×6	300+60=360	130+50+300=480	480-50=430	130+65+25+300=520	520-65-25=430	130+65+300=495	495-65=430	130+30+300=460	460-30=430
SJ10	Φ45×8	300+65=365	160+80+300=520	520-80=440	160+95+32+300=587	587-95-32=460	160+85+300=525	525-85=440	160+40+300=500	500-40=460
SJ15	Φ50×8	300+65=365	160+80+300=520	520-80=440	160+95+32+300=587	587-95-32=460	160+85+300=525	525-85=440	160+50+300=510	510-50=460
SJ20	Φ65×10	300+75=375	180+80+300=560	560-80=480	180+114+35+300=629	629-114-35=480	180+70+300=550	550-70=480	180+55+300=535	535-55=480
SJ30	Φ75×12		220+80+300=600	600-80=520	220+135+44+300=699	699-135-44=520	220+75+300=595	595-75=520	220+65+300=585	585-65=520
SJ40	Φ80×12		260+100+300=660	660-100=560	260+150+54+300=764	764-150-54=560	260+95+300=655	655-95=560	260+70+300=630	630-70=560
SJ50	Φ90×14		315+120+300=735	735-120=615	315+165+64+300=844	844-165-64=615	315+114+300=729	729-114=615	315+75+300=690	690-75=615
SJ100	Φ100×16		345+150+300=795	795-150=645	345+200+70+300=915	915-200-70=645	345+140+300=785	785-140=645	345+100+300=745	745-100=645

减速器润滑

润滑油种类选择

减速器使用工况	润滑油种类
冶金轧钢、井下采掘、高温有冲击、含水等	L-CKD重载荷工业齿轮油 (GB5903-1995)
其余工况	L-CKC中载荷工业齿轮油 (GB5903-1995)

注:若选用合成齿轮油则更具有良好的抗老化性能,可有效地提高减速器的机械效率。

润滑油粘度

条件	润滑油粘度等级 40°C温度下的ISO-VG 粘度 mm ² /s ² (cst)
高速级圆周速度 v < 2.5 m/s, 或环境温度在 35~50°C 之间	VG320 (或 VG460)
高速级齿轮圆周速度 v > 2.5 m/s, 或环境温度在 35°C 以下, 或采用循环油润滑	VG220

浸油润滑润滑油的工作温度

润滑油种类	工作温度/°C
中载荷工业齿轮油 L-CKC	-8°C 至 +90°C (瞬时可达 100°C)
重载荷工业齿轮油 L-CKD	-5°C 至 +100°C (瞬时可达 110°C)
蜗轮蜗杆油 L-CKE/P	-5°C 至 +100°C (瞬时可达 110°C)

注意:如果减速器的工作温度高于或低于表中规定极限值则应重新确定合适的润滑油。
当环境温度低于 0°C 时启动前油温需加热到 0°C 以上。

强制润滑润滑油允许的极限温度

40°C 温度下的 ISO-VG 粘度 mm ² /s ² (cst)	强制润滑允许的极限温度/°C	
	矿物油	合成油
VG220	10-80	0-90
VG320	15-90	5-100
VG460	20-95	10-105

注意:当油温低于表中所列数值时,必须提供浸油润滑方式,或对润滑油加热。

Gear Units Lubrication

Lubricant selection

Operating conditions of gear units	Lubricant specification
Steel rolling, excavating, high temperature with shock, moisture, etc.	L-CKD heavy load industrial gear oil (GB5903-1995)
Others	L-CKC moderate load industrial gear oil (GB5903-1995)

Note: It adopts the synthetic oil which has the better performance of anti-ageing so that improves the mechanical efficiency effectively.

Lubricant viscosity

Conditions	Lubricant viscosity classification Viscosity ISO-VG at 40°C in mm ² /s(cst)
Rotation velocity of high speed stage v < 2.5 m/s, or ambient temperature between 35~50°C	VG320 (or VG460)
Rotation velocity of high speed stage v > 2.5 m/s, or ambient temperature at 35°C, or lubrication with circulating oil	VG220

Working temperature for dip feed lubrication

Lubricant specification	Working temperature/°C
L-CKC moderate load industrial gear oil	From -8°C to +90°C (up to 100°C at moment)
L-CKD heavy load industrial gear oil	From -5°C to +100°C (up to 110°C at moment)

Notes: If the temperatures of gear units are above or below the values as listed in table, it determines the proper oil again. If the ambient temperatures are below 0°C, the oil has to be heated above 0°C.

Permissible temperature limit for forced feed lubrication

Viscosity ISO-VG at 40°C in mm ² /s(cst)	Permissible temperature limit for forced feed lubrication/°C	
	Mineral oil	Synthetic oil
VG220	10-80	0-90
VG320	15-90	5-100
VG460	20-95	10-105

Notes: If the temperatures are below the values as listed in table, dip lubrication has to be provided or the oil must be heated.

标准普通电机和特殊电机的参数及安装尺寸

Standard and ordinary motor or special motor parameter and mounting dimension

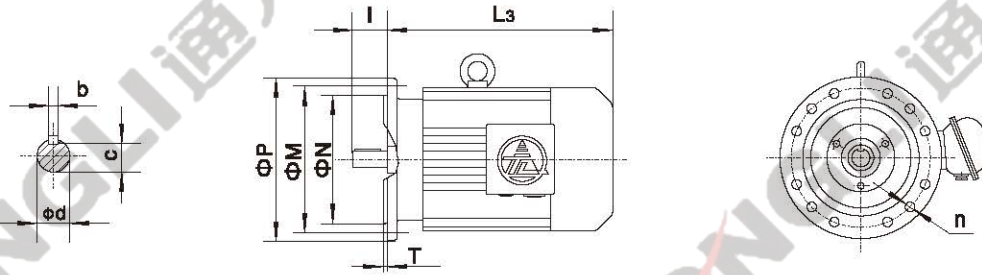

电机 机座号 Motor size	4极 4 Pole		6极 6 Pole		8极 8 Pole		L3				安装尺寸 Mounting dimensions								M(kg)					
	P1 (kW)	n1 (r/min)	P1 (kW)	n1 (r/min)	P1 (kW)	n1 (r/min)	Y ₂	B	E	V	M	N	P	n	T	d	l	b	c	Y (铝壳 Aluminum housing)	Y ₂	B	E	V
63M1	0.12	1390																		5.5	13			11
63M2	0.18	1390					202	270	328		115	95j6	140	4xΦ10	3	11j6	23	4	8.5	6	13.5	15		12
71M1	0.25	1390	0.18	850																6.5	14	16	12	14
71M2	0.37	1390	0.25	850			225	285	345		130	110j6	160	4xΦ10	3.5	14j6	30	5	11	7.5	14.5	16	13	15
80M1	0.55	1390	0.37	885	0.18	645														10	15	31	20	16
80M2	0.75	1390	0.55	885	0.25	645	255	290	350	310	165	130j6	200	4xΦ12	3.5	19j6	40	6	15.5	11	16	32	21	17
90S	1.1	1400	0.75	910	0.37	670	270	310	370	320	165	130j6	200	4xΦ12	3.5	24j6	50	8	20	16	23	35	27	23
90L	1.5	1400	1.1	910	0.55	670	295	335	395	345	165	130j6	200	4xΦ12	3.5	24j6	50	8	20	20	25	39	31	28
100L1	2.2	1420	1.5	920	0.75	680															33	49	41	35
100L2	3	1420			1.1	680	325	370	420	370	215	180j6	250	4xΦ15	4	28j6	60	8	24			35	53	44
112M	4	1440	2.2	940	1.5	690	340	400	450	390	215	180j6	250	4xΦ15	4	28j6	60	8	24		41	67	60	43
132S	5.5	1440	3	960	2.2	710	390	430	505	450	265	230j6	300	4xΦ15	4	38k6	80	10	33		65	93	85	63
132M	7.5	1460	4	960	3	710	430	470	545	490	265	230j6	300	4xΦ15	4	38k6	80	10	33		76	105	98	75
			5.5	960																				
160M	11	1460	7.5	960	4	720	505	545	610	550	300	250h6	350	4xΦ19	5	42k6	110	12	37		118	150	143	116
					5.5	720																		
160L	15	1460	11	960	7.5	720	560	585	655	595	300	250h6	350	4xΦ19	5	42k6	110	12	37		132	169	165	136
180M	18.5	1470	/	/	/	/	590	620	715	740	300	250h6	350	4xΦ19	5	48k6	110	14	42.5		164	205	203	169
180L	22	1470	15	970	11	730	630	640	765	790	300	250h6	350	4xΦ19	5	48k6	110	14	42.5		182	222	216	183
200L	30	1470	18.5	970	15	730	660	695	790	850	350	300h6	400	4xΦ19	5	55k6	110	16	49		245	300	296	236
			22	970																				
225S	37	1480	/	/	18.5	730	675	705	860	910	400	350h6	450	8xΦ19	5	60m6	140	18	53		258	360	370	291
225M	45	1480	30	980	22	730	705	730	890	940	400	350h6	450	8xΦ19	5	60m6	140	18	53		290	390	405	327
250M	55	1480	37	980	30	730	770	795		1060	500	450h6	550	8xΦ19	5	65m6	140	18	58		388	530	498	393
280S	75	1480	45	980	37	730	845	870		1160	500	450h6	550	8xΦ19	5	75m6	140	20	67.5		510	660	633	520
280M	90	1485	55	980	45	740	895	920		1260	500	450h6	550	8xΦ19	5	75m6	140	20	67.5		606	785	723	610
315S	110	1485	75	980	55	740	1100	1100		1330	600	550h6	660	8xΦ24	6	80m6	170	22	71		910	1000	1150	950
315M	132	1485	90	985	75	740	1180	1180		1380	600	550h6	660	8xΦ24	6	80m6	170	22	71		1000	1100	1230	1030
315L	160	1485	110	985	90	740	1270	1270		1450	600	550h6	660	8xΦ24	6	80m6	170	22	71		1055	1100	1320	1100
	200	1485	132	985	110	740																		

注：由于结构需要及生产厂家不同，有时参数会有所变化，此表仅供参考，准确尺寸请来电垂询。

Note: Sometimes the parameters may be changed with the different structures and manufacturers, this table is only for reference, please refer to us for the exact dimensions.

APPLICATION
FIELDS

应用领域



钢铁冶金
Steel metallurgy



橡胶塑料
Rubber plastic



石油化工
Petrochemical



环保生态
Environmental
Protection



电力设备
Power equipment



建材机械
Building materials
machinery



港口机械
Port machinery



煤矿机械
Coal mining
machinery



工程机械
Construction
machinery



起重运输
Lifting and
transportation

PROCESSING AND
TESTING EQUIPMENT

加工和检测设备

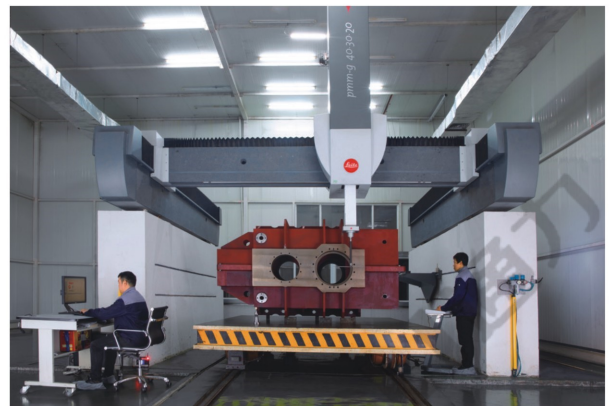

公司荣誉



本册所有产品、设备、场景均为通力科技实景拍摄或三维建模渲染，
图片版权归通力科技所有。

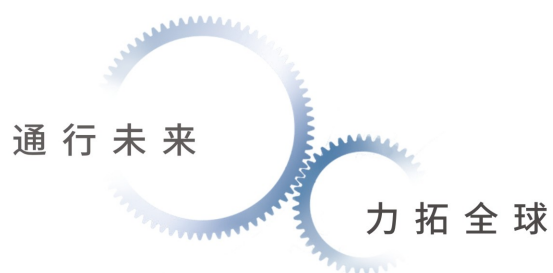

浙江通力传动科技股份有限公司

ZHEJIANG TONGLI TRANSMISSION TECHNOLOGY CO.,LTD

营 销：+86 577 6559 1111 +86 577 6559 2222

售 后：+86 577 6559 3333

传 真：+86 577 6559 8888

网 址：www.zjtongli.com

邮 箱：65598888@zjtongli.com

地 址：浙江省瑞安市江南大道3801号(通力传动科技园)
No. 3801 Jiangnan Road, Rui'an Wenzhou City,
Zhejiang Province, 325207, China



企业官网



企业公众号